

MITSUBISHI RF POWER TRANSISTOR 2SC3017

NPN EPITAXIAL PLANAR TYPE

DESCRIPTION

2SC3017 is a silicon NPN epitaxial planar type transistor specifically designed for VHF power amplifiers applications.

FEATURES

- High power gain: $G_{pe} \geq 11 \text{ dB}$
@ $V_{CC} = 7.2 \text{ V}$, $f = 175 \text{ MHz}$, $P_{in} = 0.1 \text{ W}$
- Emitter ballasted construction.
- Emitter case type TO-39 package.
(connected internally to emitter)
- $Z_{in} = 8 - j12 \Omega$, $Z_{out} = 11 - j1 \Omega$
@ $V_{CC} = 7.2 \text{ V}$, $f = 175 \text{ MHz}$, $P_O = 1.5 \text{ W}$.

APPLICATION

For drive stage and output stage of power amplifiers in VHF band portable radio sets.

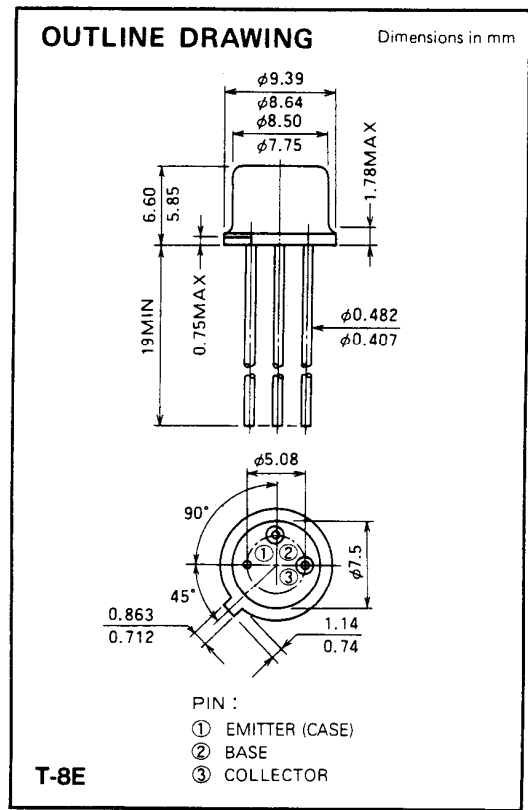

ABSOLUTE MAXIMUM RATINGS ($T_C = 25^\circ \text{C}$)

Symbol	Parameter	Conditions	Ratings	Unit
V_{CBO}	Collector to base voltage		20	V
V_{EBO}	Emitter to base voltage		3.5	V
V_{CEO}	Collector to emitter voltage	$R_{BE} = \infty$	9	V
I_C	Collector current		1	A
P_C	Collector dissipation	$T_C = 25^\circ \text{C}$	4	W
T_J	Junction temperature		175	$^\circ \text{C}$
T_{stg}	Storage temperature		-55 to 175	$^\circ \text{C}$

Note: Above parameters are guaranteed independently.

ELECTRICAL CHARACTERISTICS ($T_C = 25^\circ \text{C}$)

Symbol	Parameter	Test conditions	Limits			Unit
			Min	Typ	Max	
$V_{(BR)EBO}$	Emitter to base breakdown voltage	$I_E = 1 \text{ mA}$, $I_C = 0$	3.5			V
$V_{(BR)CBO}$	Collector to base breakdown voltage	$I_C = 10 \text{ mA}$, $I_E = 0$	20			V
$V_{(BR)CEO}$	Collector to emitter breakdown voltage	$I_C = 10 \text{ mA}$, $R_{BE} = \infty$	9			V
I_{CBO}	Collector cut off current	$V_{CB} = 10 \text{ V}$, $I_E = 0$			200	$\mu \text{ A}$
I_{EBO}	Emitter cut off current	$V_{EB} = 2 \text{ V}$, $I_C = 0$			200	$\mu \text{ A}$
h_{FE}	DC forward current gain *	$V_{CE} = 5 \text{ V}$, $I_C = 0.1 \text{ A}$	20	50	180	—
P_O	Power Output	$V_{CC} = 7.2 \text{ V}$, $P_{in} = 0.1 \text{ W}$, $f = 175 \text{ MHz}$	1.5	2.0		W
η_C	Collector efficiency		55	60		%

Note: * Pulse test, $P_W = 150 \mu \text{ s}$, $\text{duty} = 5\%$.

Above parameters, ratings, limits and conditions are subject to change.

NOV. ' 97

NPN EPITAXIAL PLANAR TYPE

TEST CIRCUIT (f = 175MHz)

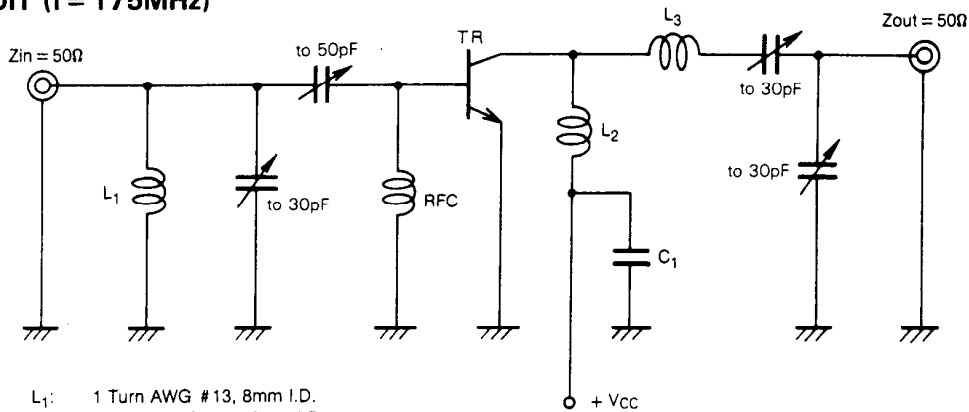

- L₁: 1 Turn AWG #13, 8mm I.D.
- L₂: 4 Turns AWG #13, 8mm I.D.
- L₃: 2 Turns AWG #13, 8mm I.D.
- RFC: 20 Turns AWG #26 Enameled wire Close Wound on 4mm O.D., 14mm Length Bakelite.
- C₁: 0.022μF, 0.047μF, 0.1μF in parallel.

TYPICAL PERFORMANCE DATA

COLLECTOR DISSIPATION VS. AMBIENT TEMPERATURE CHARACTERISTICS.

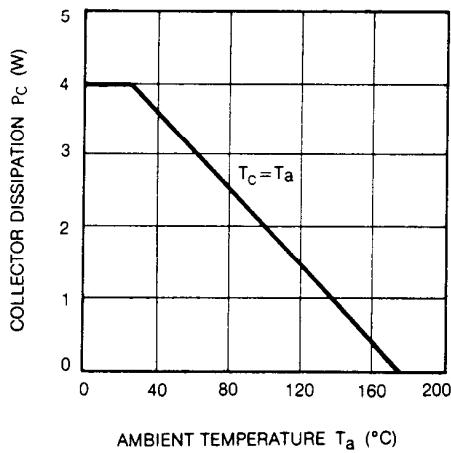

OUTPUT POWER, COLLECTOR EFFICIENCY VS. INPUT POWER CHARACTERISTICS.

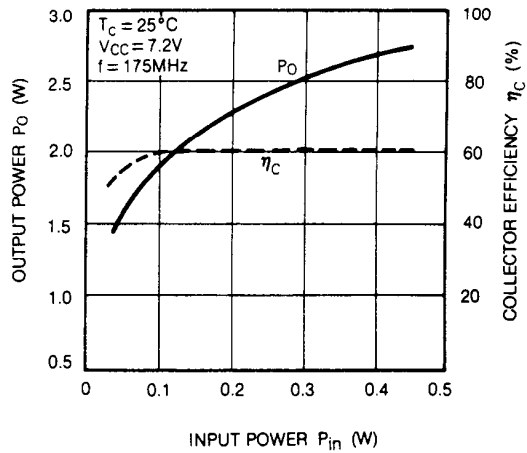

OUTPUT POWER VS. COLLECTOR SUPPLY VOLTAGE CHARACTERISTICS

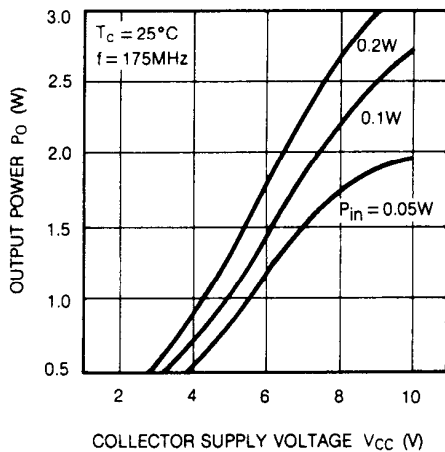

COLLECTOR OUTPUT CAPACITANCE VS. COLLECTOR TO BASE VOLTAGE CHARACTERISTICS.

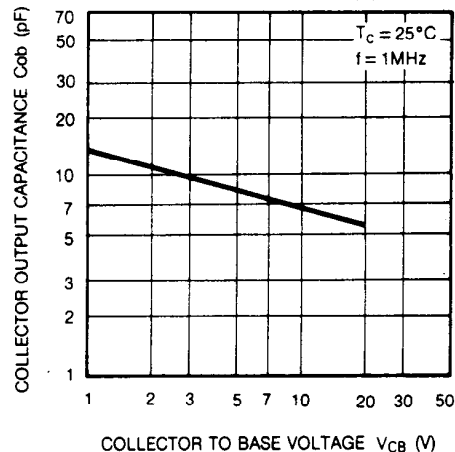



LittleDiode supplies new, hard to find or obsolete electronic components and semiconductors all over the world.

With over two million different components listed you are sure to find the part you need.

Feel free to visit us today at our online store:

LittleDiode.com

Looking forward to providing you with the best possible service.