

Zener Transient Voltage Suppressors

**1SMA5.0AT3
through
1SMA78AT3**

Specification Features:

- Reverse Stand-Off Voltage Range: 5.0–78 V
- Peak Power — 400 Watts @ 1.0 ms
- ESD Rating of Class 3 (>16 kV) per Human Body Model
- Pico Seconds Response Time (0 V to BV)
- Flat Handling Surface for Accurate Placement
- Package Design for Top Side or Bottom Circuit Board Mounting
- Available in Tape and Reel
- Low Profile Package

**PLASTIC SURFACE MOUNT
ZENER OVERVOLTAGE
TRANSIENT SUPPRESSORS
5.0–78 VOLTS V_R
400 WATTS PEAK POWER**

Mechanical Characteristics:

- Case: Void-free, transfer-molded plastic
- Maximum Case Temperature for Soldering Purposes: 260°C for 10 seconds
- Finish: All external surfaces are corrosion resistant with readily solderable leads
- Polarity: Cathode indicated by molded polarity notch
- Mounted Position: Any



**SMA
CASE 403B-01
PLASTIC**

MAXIMUM RATINGS AND CHARACTERISTICS

Rating	Symbol	Value	Unit
Peak Power Dissipation @ $T_L = 25^\circ\text{C}$, $PW = 10/1000 \mu\text{s}$ (Note 1)	P_{pk}	400	Watts
Peak Forward Surge @ $T_A = 25^\circ\text{C}$ (JEDEC Method, Note 2)	I_{FSM}	40	Amps
Thermal Resistance from Junction to Lead	$R_{\theta JL}$	29	$^\circ\text{C/W}$
Thermal Resistance from Junction to Ambient	$R_{\theta JA}$	150	$^\circ\text{C/W}$
Instantaneous Forward Voltage @ 40 A	V_F	3.5	Volts
Operating and Storage Junction Temperature Range	T_J, T_{stg}	150	$^\circ\text{C}$

* FR4 Board, using Motorola minimum recommended footprint, as shown in case 403B outline dimensions spec.

1. Non-repetitive current pulse.
2. Measured on 0.3 ms single half sine-wave or equivalent square wave, duty cycle = 4 pulse per minute maximum.

ELECTRICAL CHARACTERISTICS ($V_F = 3.5$ Volts @ $I_F = 40$ A for all types)

Device	Reverse Stand-off Voltage V_{RWM} (Volts)	Breakdown Voltage		Maximum Reverse Voltage @ I_{RSM} (Clamping Voltage) V_{RSM} (Volts)	Maximum Reverse Surge Current I_{RSM} (Amps)	Maximum Reverse Leakage @ V_{RWM} I_R (μA)	Device Marking
		V_{BR} Volts (Min)	I_T mA				
1SMA5.0AT3	5.0	6.4	10	9.2	43.5	400	QE
1SMA6.0AT3	6.0	6.67	10	10.3	38.8	400	QG
1SMA6.5AT3	6.5	7.22	10	11.2	35.7	250	QK
1SMA7.0AT3	7.0	7.78	10	12.0	33.3	250	QM
1SMA7.5AT3	7.5	8.33	1	12.9	31.0	50	QP
1SMA8.0AT3	8.0	8.89	1	13.6	29.4	25	QR
1SMA8.5AT3	8.5	9.44	1	14.4	27.8	5.0	QT
1SMA9.0AT3	9.0	10	1	15.4	26.0	2.5	QV

* TOLERANCE AND VOLTAGE DESIGNATION Tolerance designation – The type number listed indicates a tolerance of $\pm 5\%$. (continued)

ELECTRICAL CHARACTERISTICS — continued ($V_F = 3.5$ Volts @ $I_F = 40$ A for all types)

Device	Reverse Stand-off Voltage V_{RWM} (Volts)	Breakdown Voltage		Maximum Reverse Voltage @ I_{RSM} (Clamping Voltage) V_{RSM} (Volts)	Maximum Reverse Surge Current I_{RSM} (Amps)	Maximum Reverse Leakage @ V_{RWM} I_R (μ A)	Device Marking
		V_{BR} Volts (Min)	I_T mA				
1SMA10AT3	10	11.1	1	17.0	23.5	2.5	QX
1SMA11AT3	11	12.2	1	18.2	22.0	2.5	QZ
1SMA12AT3	12	13.3	1	19.9	20.1	2.5	RE
1SMA13AT3	13	14.4	1	21.5	18.6	2.5	RG
1SMA14AT3	14	15.6	1	23.2	17.2	2.5	RK
1SMA15AT3	15	16.7	1	24.4	16.4	2.5	RM
1SMA16AT3	16	17.8	1	26.0	15.4	2.5	RP
1SMA17AT3	17	18.9	1	27.6	14.5	2.5	RR
1SMA18AT3	18	20	1	29.2	13.7	2.5	RT
1SMA20AT3	20	22.2	1	32.4	12.3	2.5	RV
1SMA22AT3	22	24.4	1	35.5	11.3	2.5	RX
1SMA24AT3	24	26.7	1	38.9	10.3	2.5	RZ
1SMA26AT3	26	28.9	1	42.1	9.5	2.5	SE
1SMA28AT3	28	31.1	1	45.4	8.8	2.5	SG
1SMA30AT3	30	33.3	1	48.4	8.3	2.5	SK
1SMA33AT3	33	36.7	1	53.3	7.5	2.5	SM
1SMA36AT3	36	40	1	58.1	6.9	2.5	SP
1SMA40AT3	40	44.4	1	64.5	6.2	2.5	SR
1SMA43AT3	43	47.8	1	69.4	5.8	2.5	ST
1SMA45AT3	45	50	1	72.2	5.5	2.5	SV
1SMA48AT3	48	53.3	1	77.4	5.2	2.5	SX
1SMA51AT3	51	56.7	1	82.4	4.9	2.5	SZ
1SMA54AT3	54	60	1	87.1	4.6	2.5	TE
1SMA58AT3	58	64.4	1	93.6	4.8	2.5	TG
1SMA60AT3	60	66.7	1	96.8	4.1	2.5	TK
1SMA64AT3	64	71.1	1	103.0	3.9	2.5	TM
1SMA70AT3	70	77.8	1	113.0	3.5	2.5	TP
1SMA75AT3	75	83.3	1	121.0	3.3	2.5	TR
1SMA78AT3	78	86.7	1	126.0	3.2	2.5	TS

* TOLERANCE AND VOLTAGE DESIGNATION Tolerance designation – The type number listed indicates a tolerance of $\pm 5\%$.

RATING AND TYPICAL CHARACTERISTIC CURVES

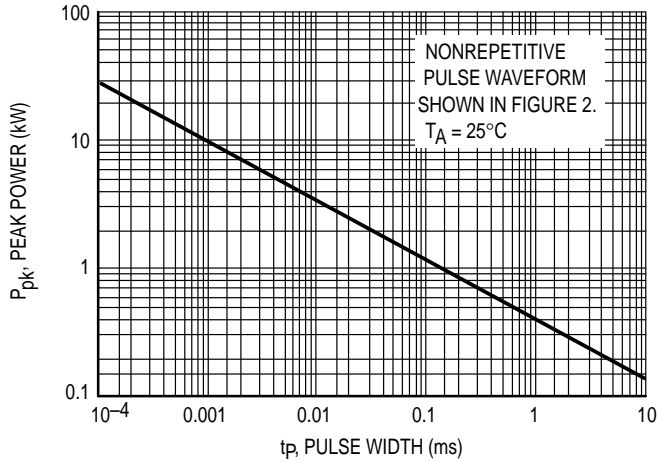

Figure 1. Pulse Rating Curve

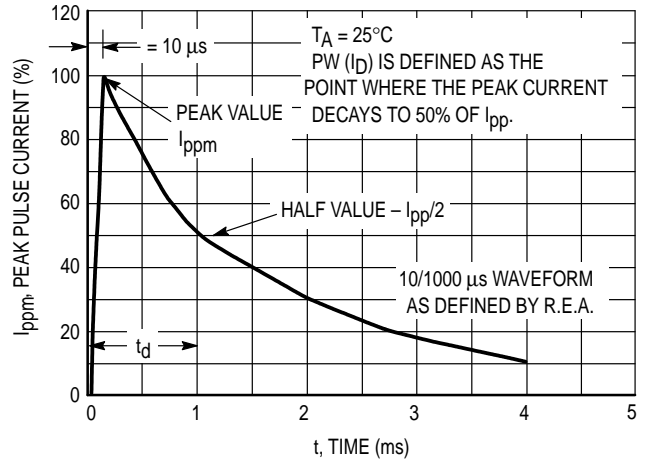

Figure 2. Pulse Waveform

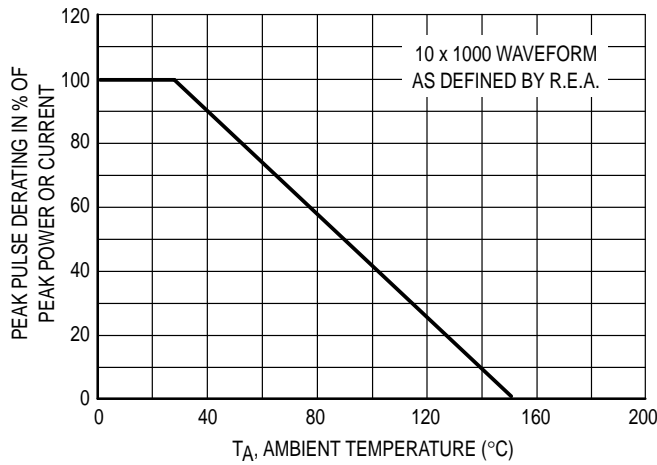

Figure 3. Pulse Derating Curve

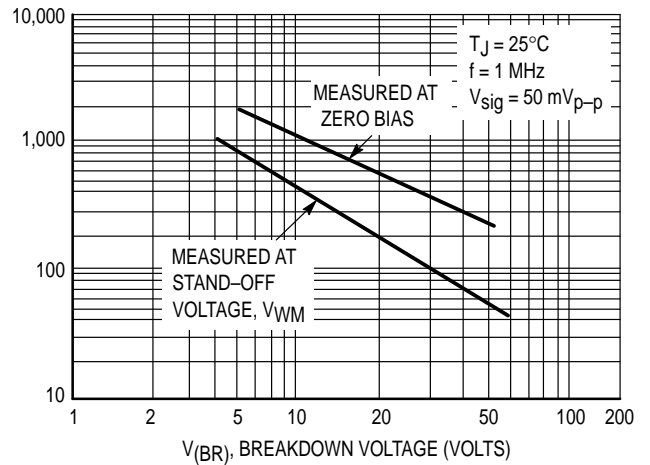

Figure 4. Typical Junction Capacitance

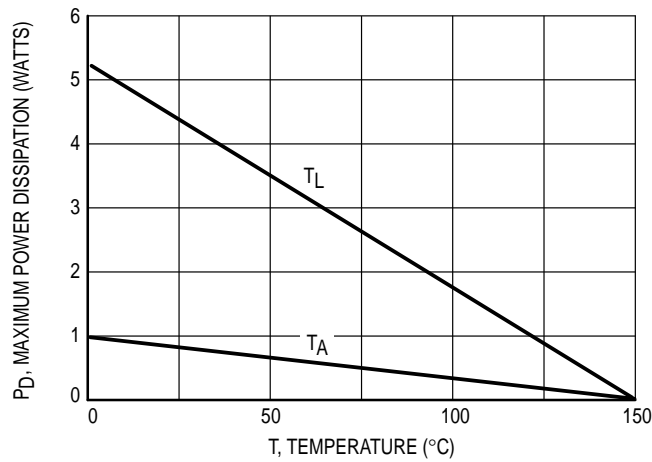
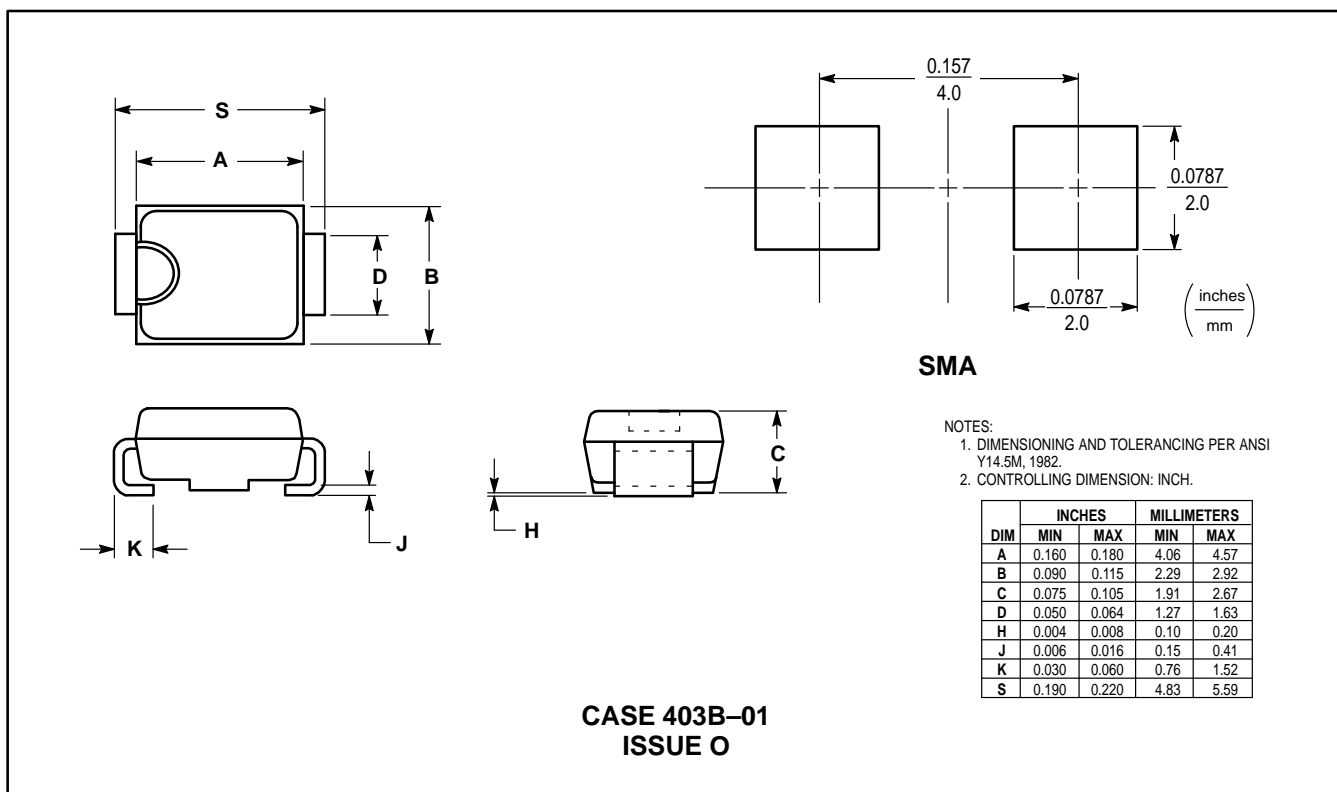

Figure 5. Steady State Power Derating

OUTLINE DIMENSIONS



Motorola reserves the right to make changes without further notice to any products herein. Motorola makes no warranty, representation or guarantee regarding the suitability of its products for any particular purpose, nor does Motorola assume any liability arising out of the application or use of any product or circuit, and specifically disclaims any and all liability, including without limitation consequential or incidental damages. "Typical" parameters which may be provided in Motorola data sheets and/or specifications can and do vary in different applications and actual performance may vary over time. All operating parameters, including "Typicals" must be validated for each customer application by customer's technical experts. Motorola does not convey any license under its patent rights nor the rights of others. Motorola products are not designed, intended, or authorized for use as components in systems intended for surgical implant into the body, or other applications intended to support or sustain life, or for any other application in which the failure of the Motorola product could create a situation where personal injury or death may occur. Should Buyer purchase or use Motorola products for any such unintended or unauthorized application, Buyer shall indemnify and hold Motorola and its officers, employees, subsidiaries, affiliates, and distributors harmless against all claims, costs, damages, and expenses, and reasonable attorney fees arising out of, directly or indirectly, any claim of personal injury or death associated with such unintended or unauthorized use, even if such claim alleges that Motorola was negligent regarding the design or manufacture of the part. Motorola and are registered trademarks of Motorola, Inc. Motorola, Inc. is an Equal Opportunity/Affirmative Action Employer.

How to reach us:

USA/EUROPE/Locations Not Listed: Motorola Literature Distribution;
 P.O. Box 20912; Phoenix, Arizona 85036. 1-800-441-2447 or 602-303-5454

MFAX: RMFAX0@email.sps.mot.com – TOUCHTONE 602-244-6609
INTERNET: http://Design-NET.com

JAPAN: Nippon Motorola Ltd.; Tatsumi-SPD-JLDC, 6F Seibu-Butsuryu-Center,
 3-14-2 Tatsumi Koto-Ku, Tokyo 135, Japan. 03-81-3521-8315

ASIA/PACIFIC: Motorola Semiconductors H.K. Ltd.; 8B Tai Ping Industrial Park,
 51 Ting Kok Road, Tai Po, N.T., Hong Kong. 852-26629298





LittleDiode supplies new, hard to find or obsolete electronic components and semiconductors all over the world.

With over two million different components listed you are sure to find the part you need.

Feel free to visit us today at our online store:

LittleDiode.com

Looking forward to providing you with the best possible service.