

DATA SHEET

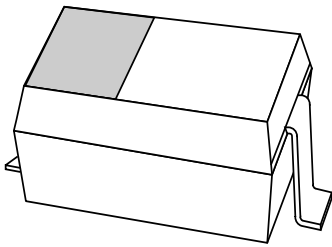

BB155

Low-voltage variable capacitance diode

Product specification

1996 Sep 20

Low-voltage variable capacitance diode

BB155

FEATURES

- Very low capacitance spread
- Excellent linearity
- Low series resistance
- Very small plastic SMD package.

APPLICATIONS

- Voltage controlled oscillators (VCO), especially in mobile communication equipment.

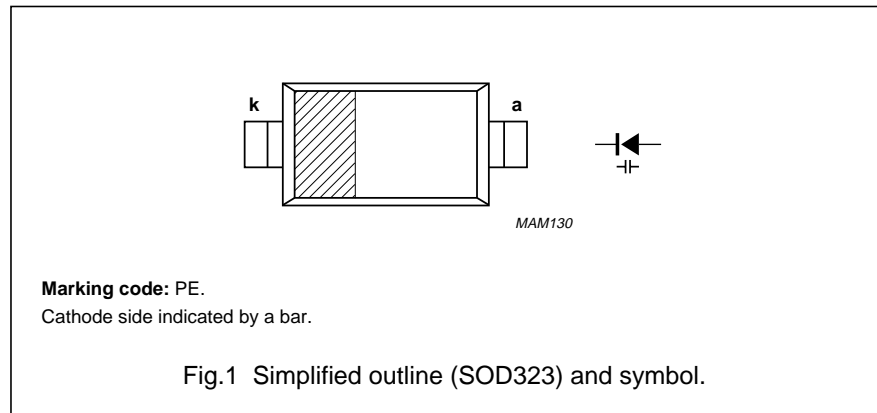

DESCRIPTION

The BB155 is a variable capacitance diode, fabricated in planar technology, and encapsulated in the SOD323 very small plastic SMD package.

LIMITING VALUES

In accordance with the Absolute Maximum Rating System (IEC 134).

SYMBOL	PARAMETER	MIN.	MAX.	UNIT
V_R	continuous reverse voltage	–	10	V
I_F	continuous forward current	–	20	mA
T_{stg}	storage temperature	–55	+150	°C
T_j	operating junction temperature	–55	+125	°C

ELECTRICAL CHARACTERISTICS

$T_j = 25\text{ °C}$; unless otherwise specified.

SYMBOL	PARAMETER	CONDITIONS	MIN.	TYP.	MAX.	UNIT
I_R	reverse current	$V_R = 10\text{ V}$; see Fig.3	–	–	10	nA
		$V_R = 10\text{ V}$; $T_j = 85\text{ °C}$; see Fig.3	–	–	200	nA
r_s	diode series resistance	$f = 100\text{ MHz}$; note 1	–	0.35	0.6	Ω
C_d	diode capacitance	$V_R = 0.34\text{ V}$; $f = 1\text{ MHz}$; see Figs 2 and 4	45.2	–	49.8	pF
		$V_R = 2.82\text{ V}$; $f = 1\text{ MHz}$; see Figs 2 and 4	24.55	–	26.7	pF

Note

1. V_R is the value at which $C_d = 30\text{ pF}$.

Low-voltage variable capacitance diode

BB155

GRAPHICAL DATA

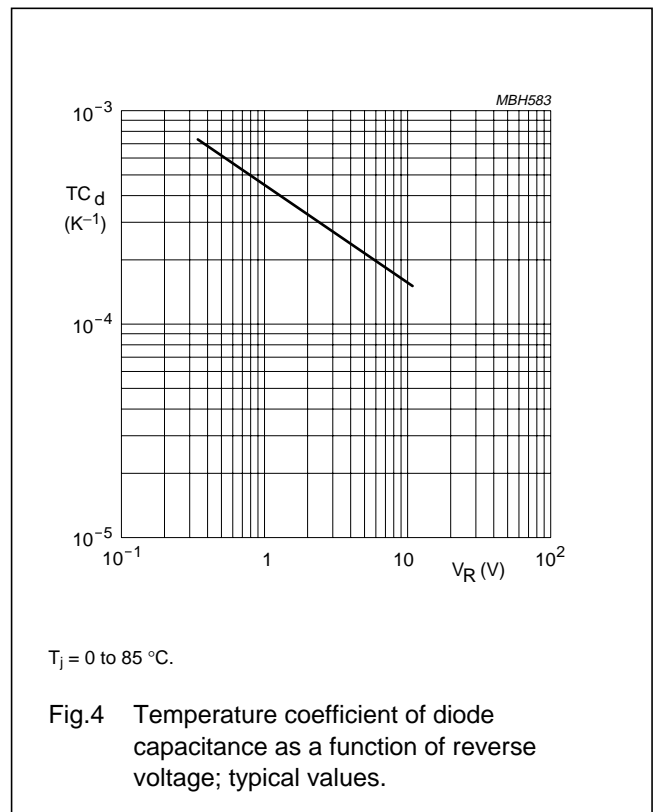
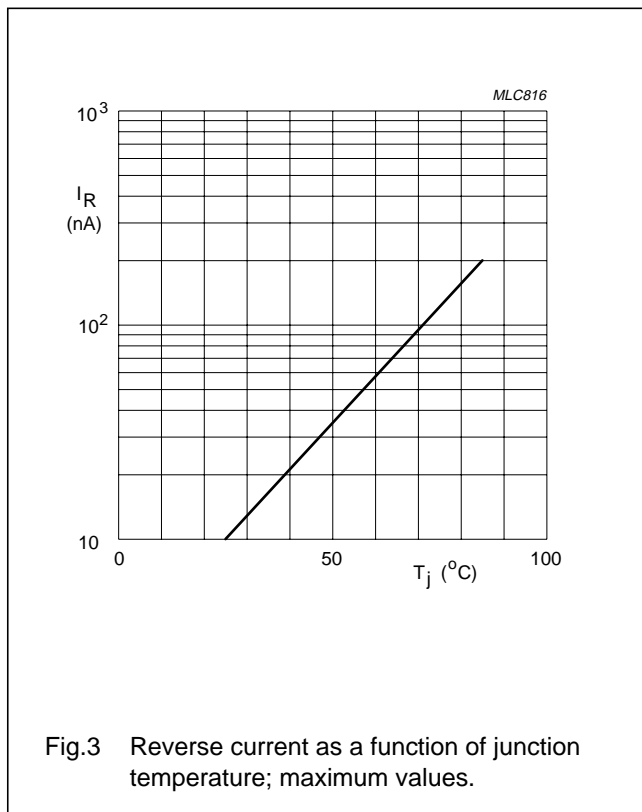
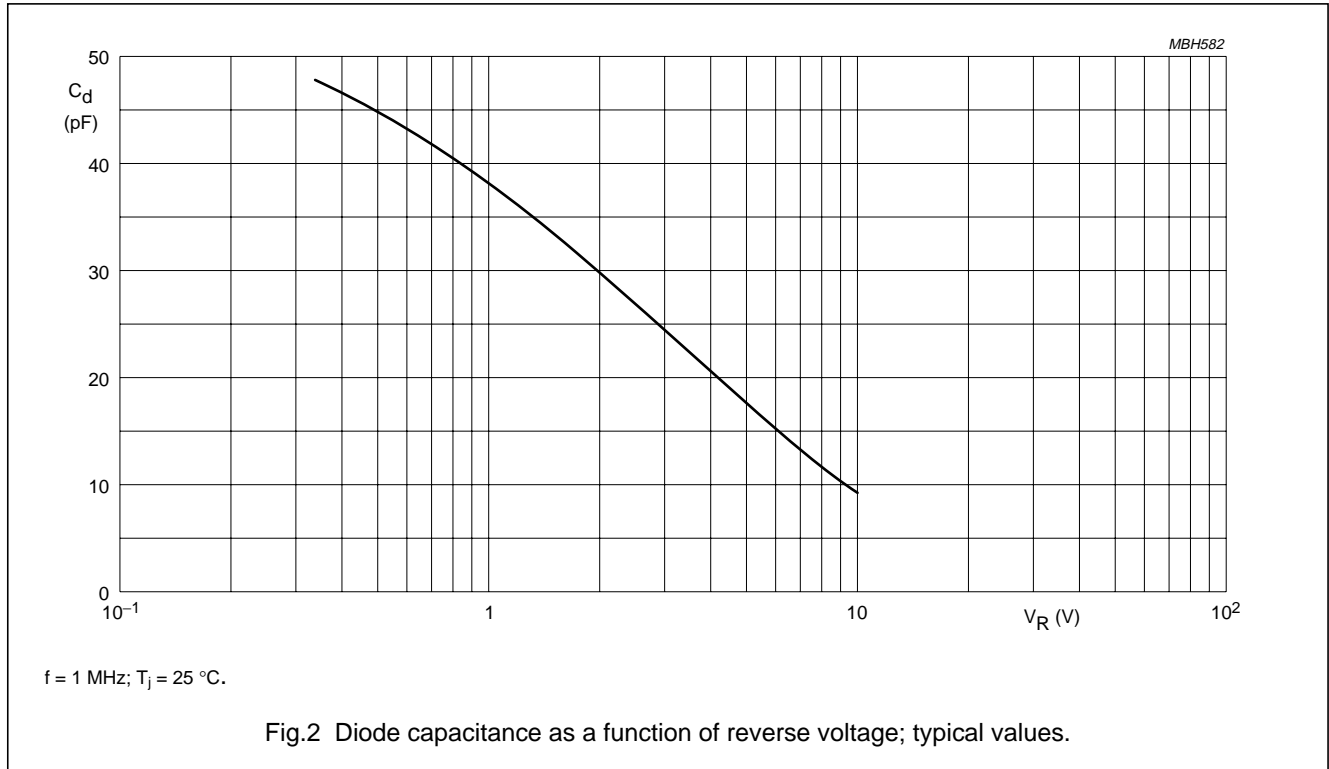

Low-voltage variable capacitance diode

BB155

PACKAGE OUTLINE

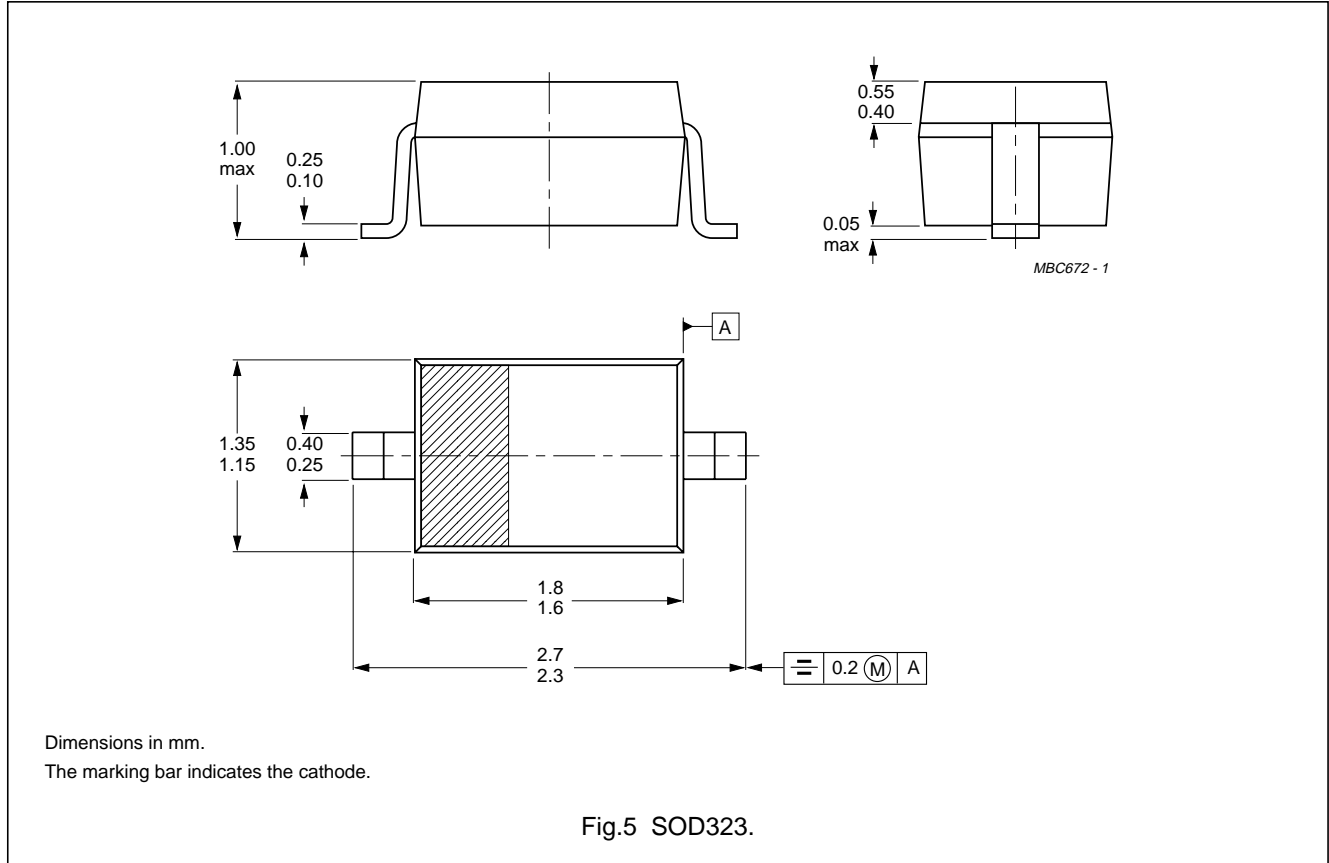

DEFINITIONS

Data sheet status	
Objective specification	This data sheet contains target or goal specifications for product development.
Preliminary specification	This data sheet contains preliminary data; supplementary data may be published later.
Product specification	This data sheet contains final product specifications.
Limiting values	
Limiting values given are in accordance with the Absolute Maximum Rating System (IEC 134). Stress above one or more of the limiting values may cause permanent damage to the device. These are stress ratings only and operation of the device at these or at any other conditions above those given in the Characteristics sections of the specification is not implied. Exposure to limiting values for extended periods may affect device reliability.	
Application information	
Where application information is given, it is advisory and does not form part of the specification.	

LIFE SUPPORT APPLICATIONS

These products are not designed for use in life support appliances, devices, or systems where malfunction of these products can reasonably be expected to result in personal injury. Philips customers using or selling these products for use in such applications do so at their own risk and agree to fully indemnify Philips for any damages resulting from such improper use or sale.



LittleDiode supplies new, hard to find or obsolete electronic components and semiconductors all over the world.

With over two million different components listed you are sure to find the part you need.

Feel free to visit us today at our online store:

LittleDiode.com

Looking forward to providing you with the best possible service.