

DATA SHEET

BSP145

N-channel enhancement mode
vertical D-MOS transistor

Product specification
File under Discrete Semiconductors, SC07

1995 Apr 24

Philips Semiconductors



PHILIPS

N-channel enhancement mode vertical D-MOS transistor

BSP145

FEATURES

- Direct interface to C-MOS, TTL, etc.
- High speed switching
- No secondary breakdown.

APPLICATIONS

- Intended for applications in relay, high speed and line transformer drivers.

DESCRIPTION

N-channel enhancement mode vertical D-MOS transistor in a SOT223 plastic SMD package.

PINNING - SOT223

PIN	SYMBOL	DESCRIPTION
1	g	gate
2	d	drain
3	s	source
4	d	drain

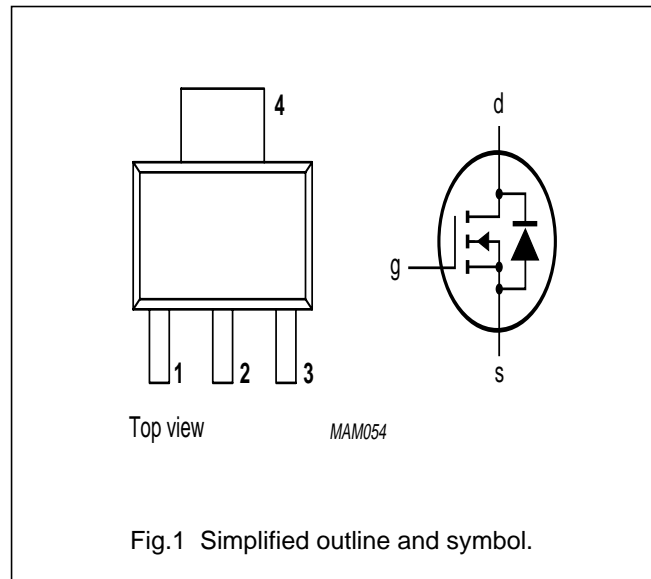

CAUTION

The device is supplied in an antistatic package. The gate-source input must be protected against static discharge during transport or handling.

QUICK REFERENCE DATA

SYMBOL	PARAMETER	CONDITIONS	TYP.	MAX.	UNIT
V_{DS}	drain-source voltage		–	450	V
V_{GSO}	gate-source voltage	open drain	–	± 20	V
V_{GSth}	gate-source threshold voltage	$I_D = 1 \text{ mA}; V_{DS} = V_{GS}$	3	4	V
I_D	drain current		–	250	mA
R_{DSon}	drain-source on-state resistance	$I_D = 100 \text{ mA}; V_{GS} = 10 \text{ V}$	10	14	Ω
P_{tot}	total power dissipation	up to $T_{amb} = 25 \text{ }^\circ\text{C}$	–	1.5	W

N-channel enhancement mode vertical D-MOS transistor

BSP145

LIMITING VALUES

In accordance with the Absolute Maximum Rating System (IEC 134).

SYMBOL	PARAMETER	CONDITIONS	MIN.	MAX.	UNIT
V_{DS}	drain-source voltage		–	450	V
V_{GSO}	gate-source voltage	open drain	–	±20	V
I_D	drain current		–	250	mA
I_{DM}	peak drain current		–	1	A
P_{tot}	total power dissipation	up to $T_{amb} = 25\text{ °C}$; note 1	–	1.5	W
T_{stg}	storage temperature		–65	+150	°C
T_j	operating junction temperature		–	150	°C

THERMAL CHARACTERISTICS

SYMBOL	PARAMETER	CONDITIONS	VALUE	UNIT
$R_{th\ j-a}$	thermal resistance from junction to ambient	note 1	83.3	K/W

Note to the “Limiting values” and “Thermal characteristics”

1. Device mounted on an epoxy printed-circuit board, $40 \times 40 \times 1.5\text{ mm}$; mounting pad for drain lead minimum 6 cm^2 .

CHARACTERISTICS

$T_j = 25\text{ °C}$ unless otherwise specified.

SYMBOL	PARAMETER	CONDITIONS	MIN.	TYP.	MAX.	UNIT
$V_{(BR)DSS}$	drain-source breakdown voltage	$V_{GS} = 0$; $I_D = 10\text{ }\mu\text{A}$	450	–	–	V
V_{GSth}	gate-source threshold voltage	$V_{DS} = V_{GS}$; $I_D = 1\text{ mA}$	2	3	4	V
I_{DSS}	drain-source leakage current	$V_{GS} = 0$; $V_{DS} = 350\text{ V}$	–	–	1	μA
I_{GSS}	gate leakage current	$V_{DS} = 0$; $V_{GS} = \pm 20\text{ V}$	–	–	±100	nA
R_{DSon}	drain-source on-state resistance	$V_{GS} = 10\text{ V}$; $I_D = 100\text{ mA}$	–	10	14	Ω
$ y_{fs} $	forward transfer admittance	$V_{DS} = 25\text{ V}$; $I_D = 250\text{ mA}$	200	–	–	mS
C_{iss}	input capacitance	$V_{GS} = 0$; $V_{DS} = 25\text{ V}$; $f = 1\text{ MHz}$	–	90	120	pF
C_{oss}	output capacitance	$V_{GS} = 0$; $V_{DS} = 25\text{ V}$; $f = 1\text{ MHz}$	–	25	35	pF
C_{rss}	reverse transfer capacitance	$V_{GS} = 0$; $V_{DS} = 25\text{ V}$; $f = 1\text{ MHz}$	–	2	5	pF
Switching times (see Figs 2 and 3)						
t_{on}	turn-on time	$V_{GS} = 0\text{ to }10\text{ V}$; $V_{DD} = 200\text{ V}$; $I_D = 100\text{ mA}$	–	–	10	ns
t_{off}	turn-off time	$V_{GS} = 10\text{ to }0\text{ V}$; $V_{DD} = 200\text{ V}$; $I_D = 100\text{ mA}$	–	–	100	ns

N-channel enhancement mode vertical D-MOS transistor

BSP145

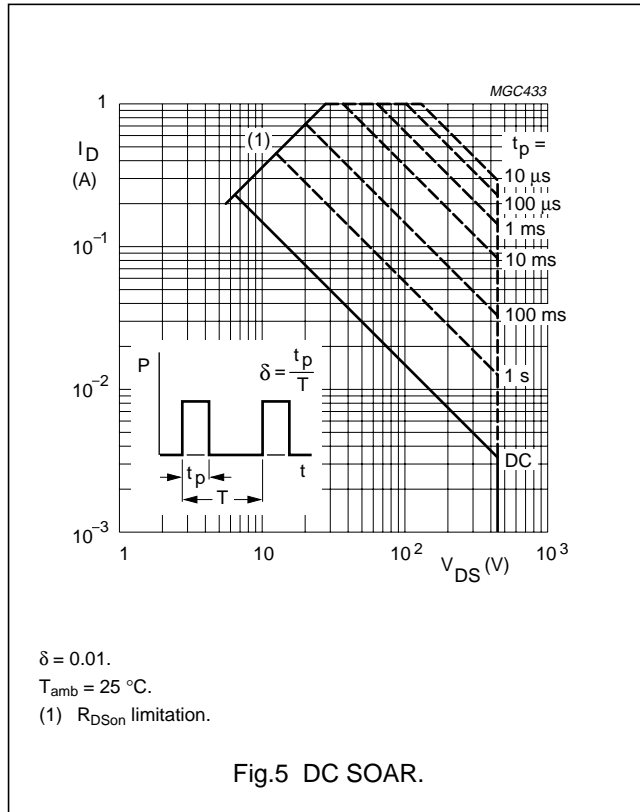
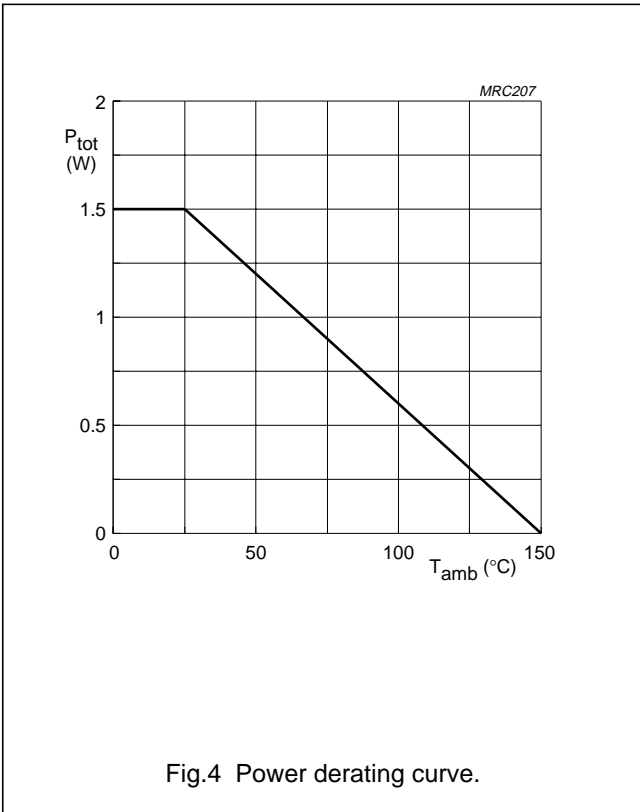
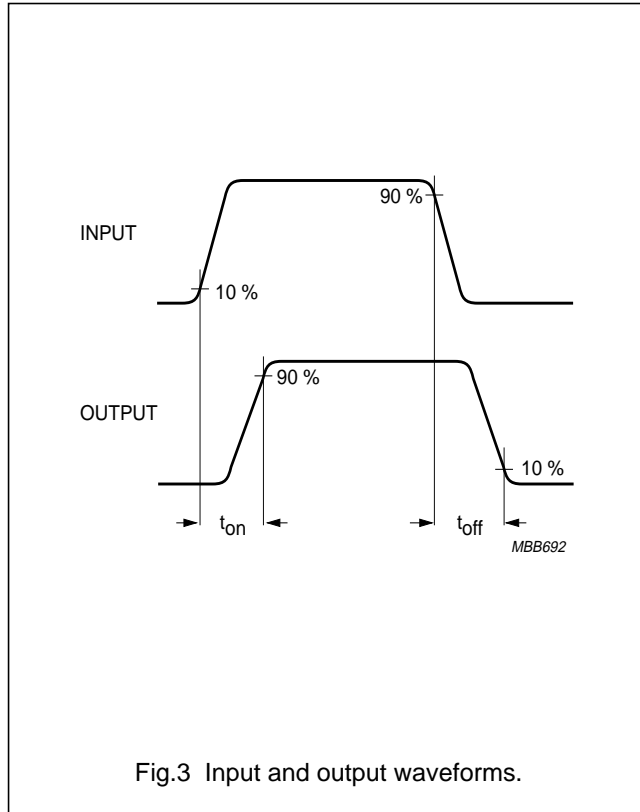
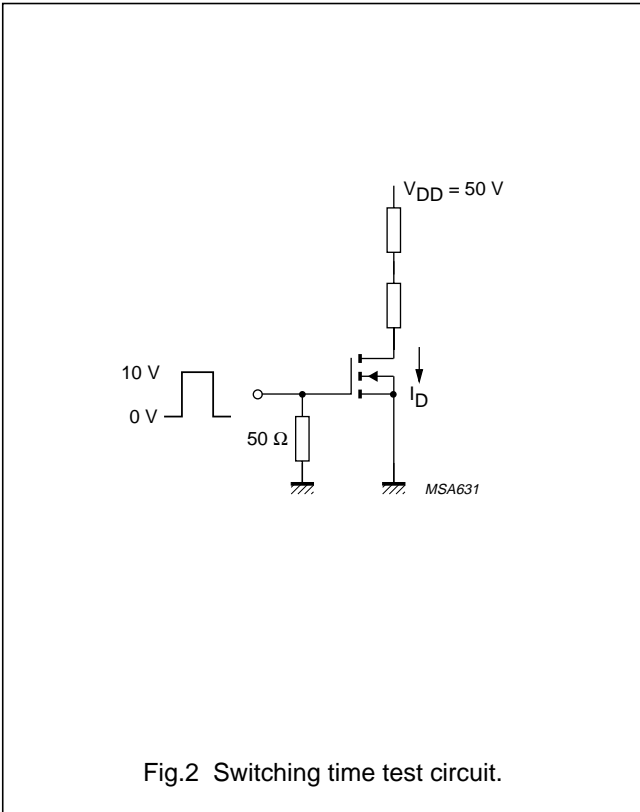

$\delta = 0.01$.
 $T_{amb} = 25\text{ }^{\circ}\text{C}$.
 (1) R_{DSon} limitation.

N-channel enhancement mode vertical D-MOS transistor

BSP145

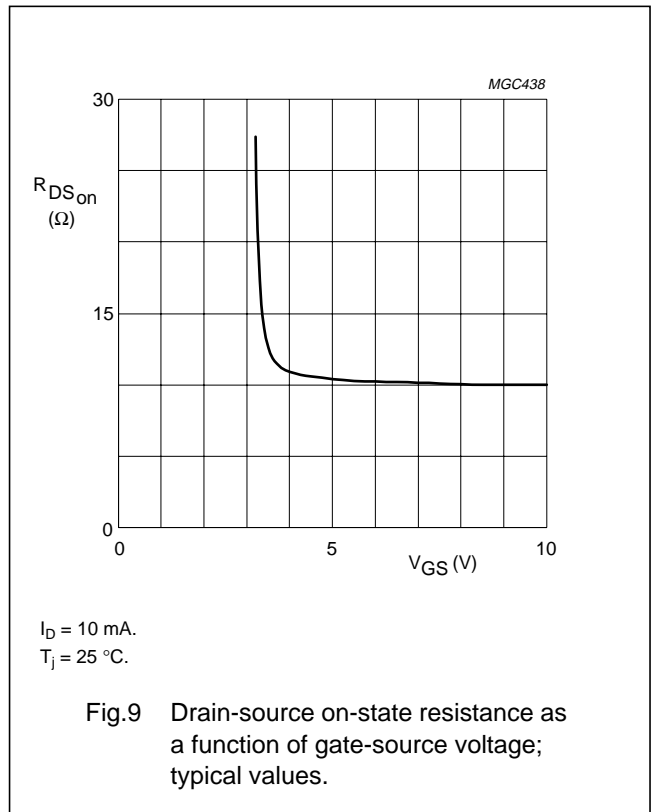
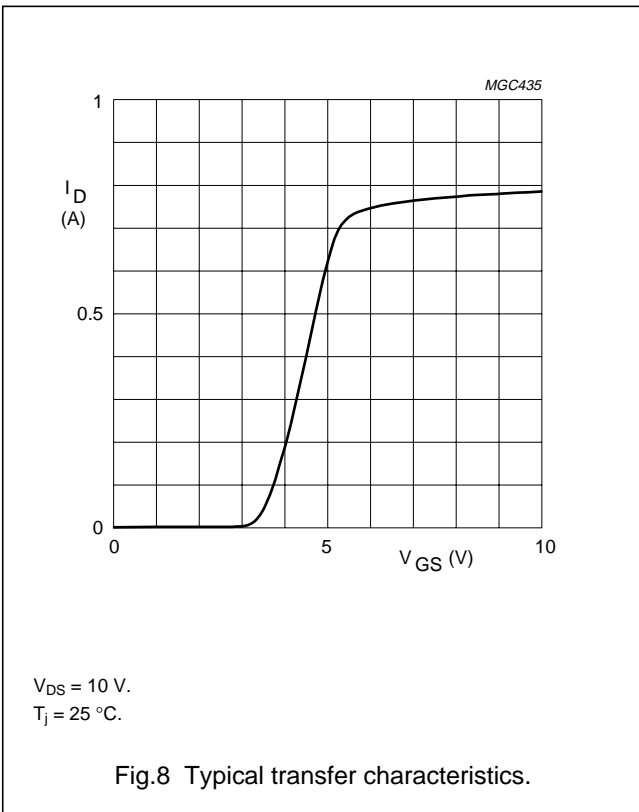
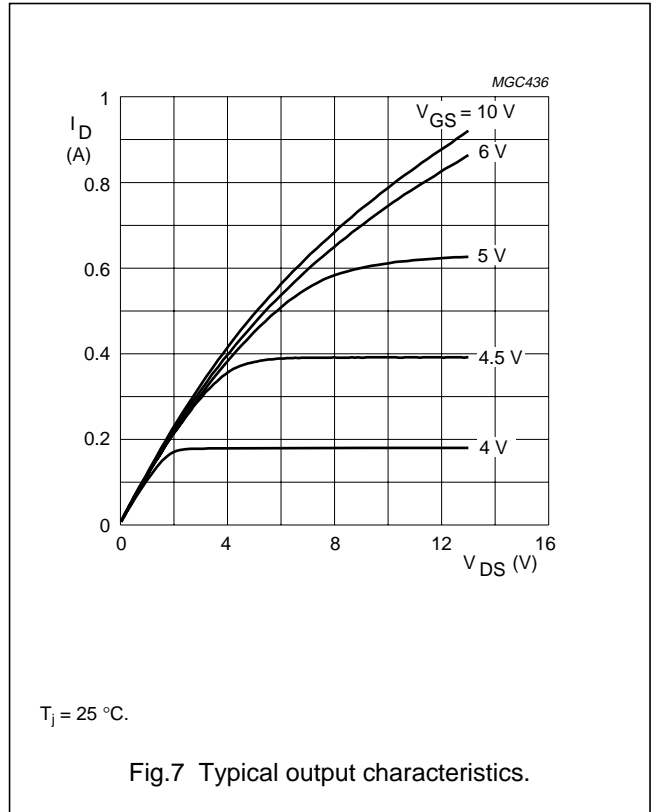
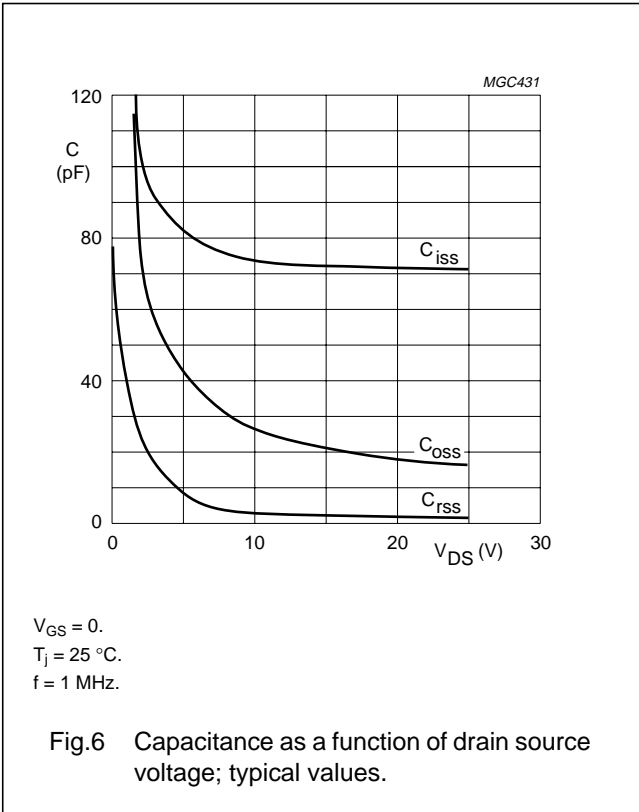

N-channel enhancement mode vertical D-MOS transistor

BSP145

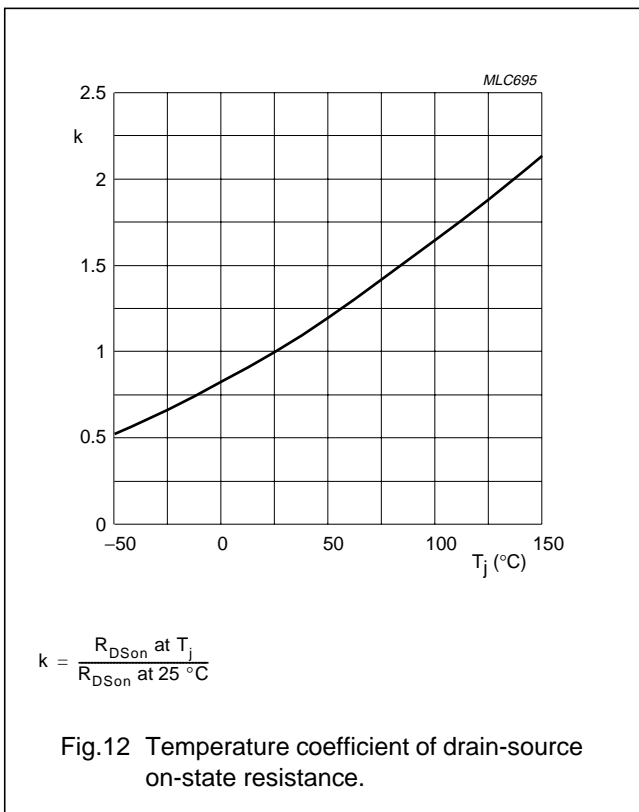
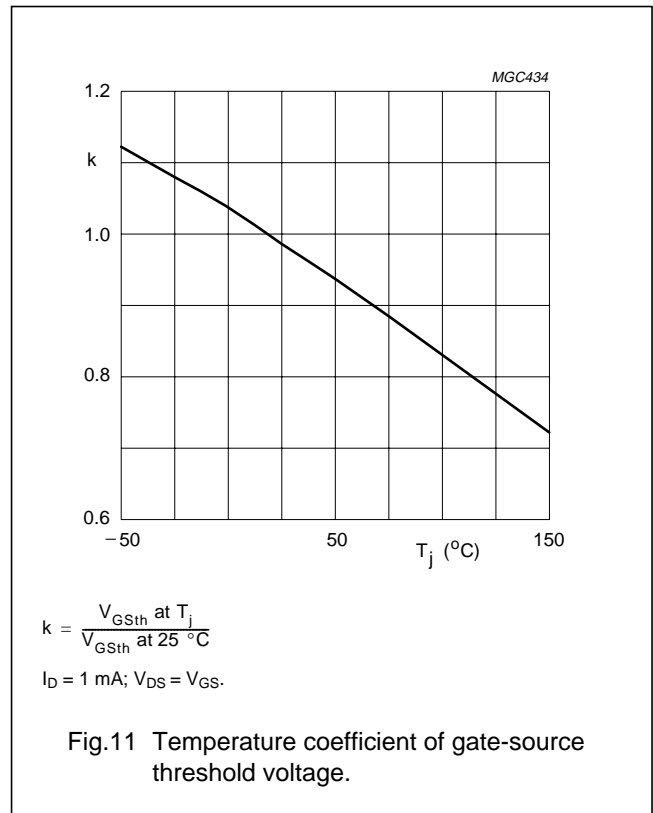
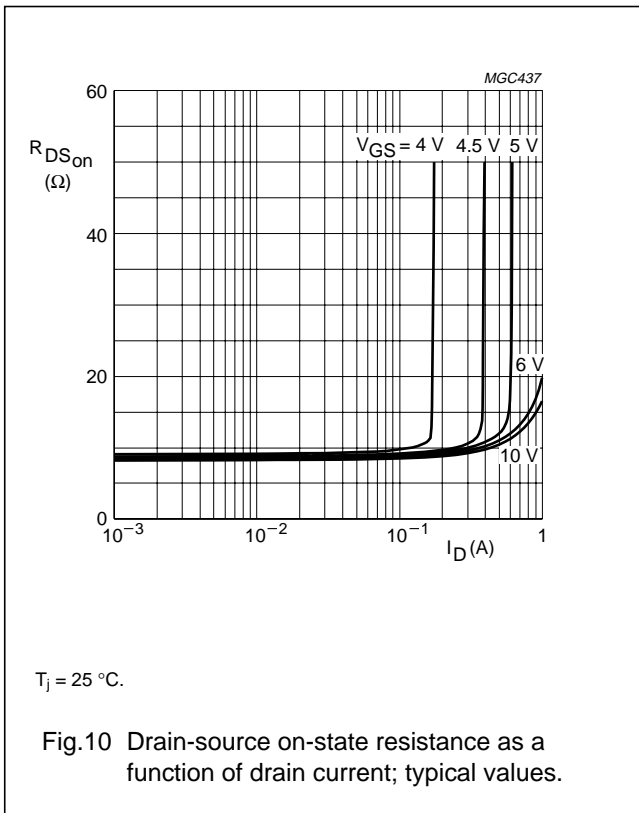

N-channel enhancement mode
vertical D-MOS transistor

BSP145

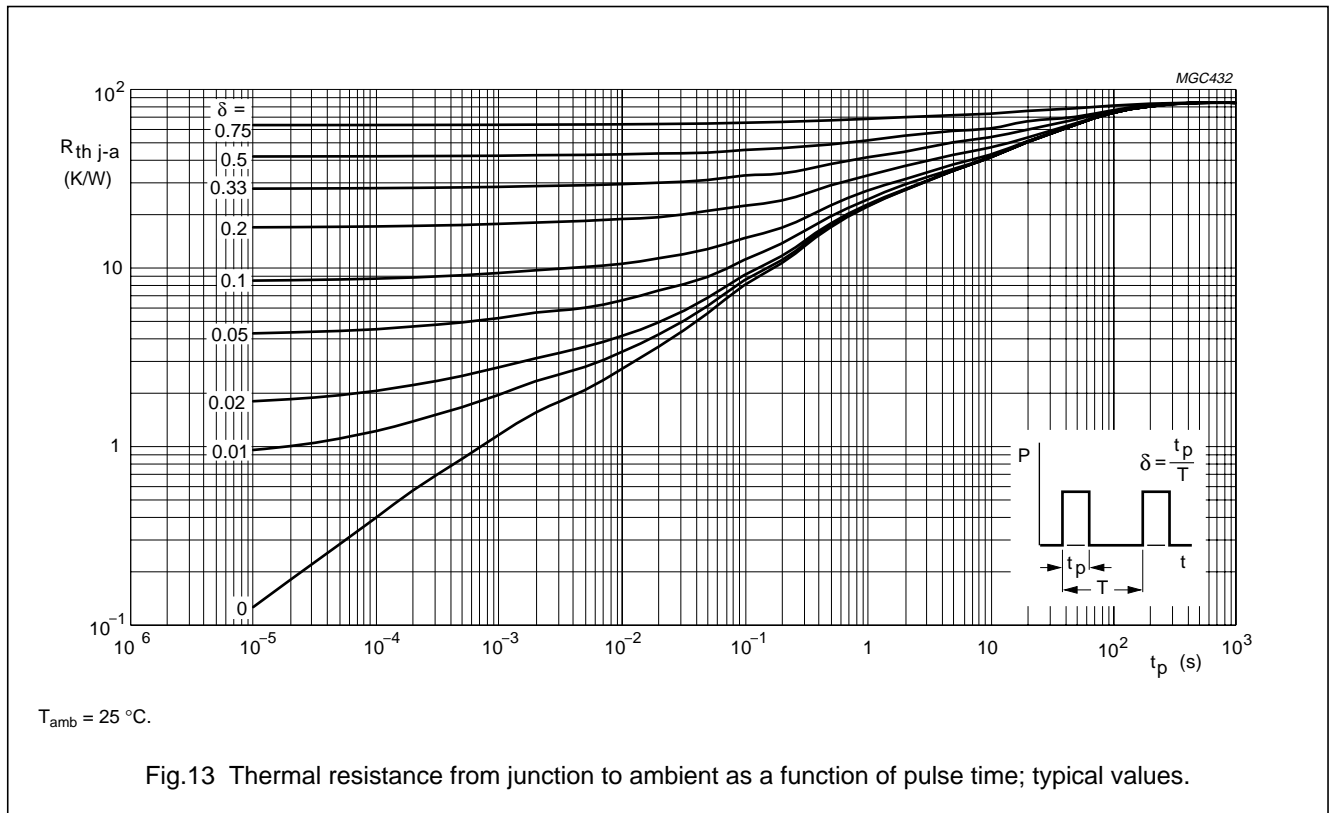
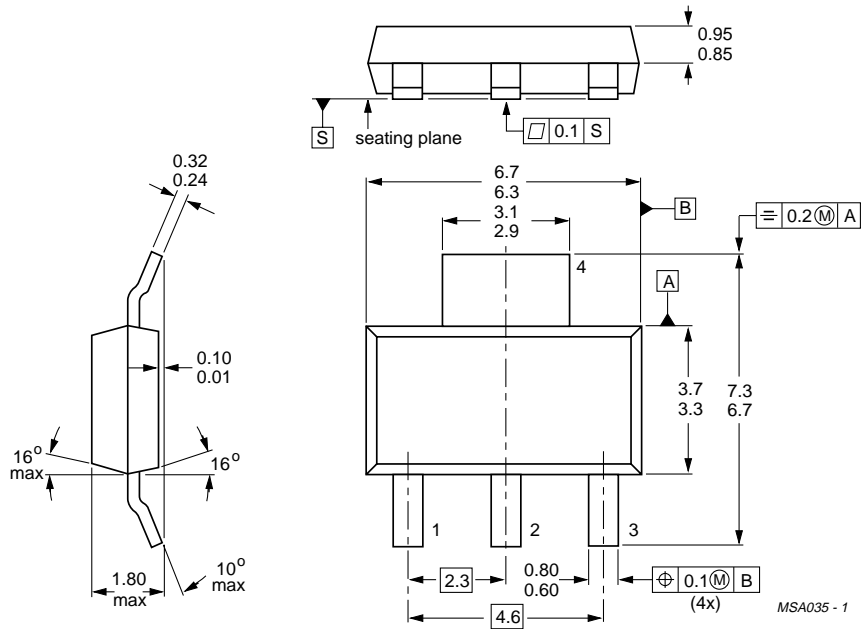

Fig.13 Thermal resistance from junction to ambient as a function of pulse time; typical values.

N-channel enhancement mode vertical D-MOS transistor

BSP145

PACKAGE OUTLINE



Dimensions in mm.

Fig.14 SOT223.

N-channel enhancement mode vertical D-MOS transistor

BSP145

DEFINITIONS

Data Sheet Status	
Objective specification	This data sheet contains target or goal specifications for product development.
Preliminary specification	This data sheet contains preliminary data; supplementary data may be published later.
Product specification	This data sheet contains final product specifications.
Limiting values	
Limiting values given are in accordance with the Absolute Maximum Rating System (IEC 134). Stress above one or more of the limiting values may cause permanent damage to the device. These are stress ratings only and operation of the device at these or at any other conditions above those given in the Characteristics sections of the specification is not implied. Exposure to limiting values for extended periods may affect device reliability.	
Application information	
Where application information is given, it is advisory and does not form part of the specification.	

LIFE SUPPORT APPLICATIONS

These products are not designed for use in life support appliances, devices, or systems where malfunction of these products can reasonably be expected to result in personal injury. Philips customers using or selling these products for use in such applications do so at their own risk and agree to fully indemnify Philips for any damages resulting from such improper use or sale.



LittleDiode supplies new, hard to find or obsolete electronic components and semiconductors all over the world.

With over two million different components listed you are sure to find the part you need.

Feel free to visit us today at our online store:

LittleDiode.com

Looking forward to providing you with the best possible service.