

DATA SHEET

BSP255

P-channel enhancement mode
vertical D-MOS transistor

Product specification
Supersedes data of 1996 Jun 13
File under Discrete Semiconductors, SC07

1996 Aug 05

P-channel enhancement mode vertical D-MOS transistor

BSP255

FEATURES

- Direct interface to C-MOS, TTL etc
- Low threshold voltage
- High speed switching
- No secondary breakdown.

APPLICATIONS

- Line current interrupter in telephone sets
- Relay, high speed and line transformer drivers.

DESCRIPTION

P-channel enhancement mode vertical D-MOS transistor in a 4-pin plastic SOT223 SMD package.

CAUTION

The device is supplied in an antistatic package. The gate-source input must be protected against static discharge during transport or handling.

PINNING - SOT223

PIN	SYMBOL	DESCRIPTION
1	g	gate
2	d	drain
3	s	source
4	d	drain

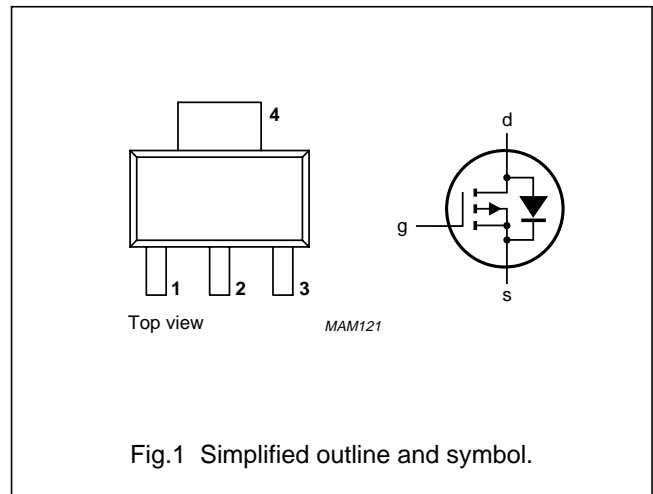

QUICK REFERENCE DATA

SYMBOL	PARAMETER	CONDITIONS	MIN.	MAX.	UNIT
V_{DS}	drain-source voltage (DC)		–	–300	V
V_{SD}	source-drain diode forward voltage	$I_S = -0.5$ A	–	–1.8	V
V_{GS}	gate-source voltage (DC)		–	±20	V
V_{GSth}	gate-source threshold voltage	$I_D = -1$ mA; $V_{DS} = V_{GS}$	–0.8	–2	V
I_D	drain current (DC)	$T_s = 100$ °C	–	–325	mA
R_{DSon}	drain-source on-state resistance	$I_D = -160$ mA; $V_{GS} = -10$ V	–	17	Ω
P_{tot}	total power dissipation	$T_s = 100$ °C	–	4	W

P-channel enhancement mode
vertical D-MOS transistor

BSP255

LIMITING VALUES

In accordance with the Absolute Maximum Rating System (IEC 134).

SYMBOL	PARAMETER	CONDITIONS	MIN.	MAX.	UNIT
V_{DS}	drain-source voltage (DC)		–	–300	V
V_{GS}	gate-source voltage (DC)		–	± 20	V
I_D	drain current (DC)	$T_S = 100\text{ }^\circ\text{C}$; note 1	–	–325	mA
I_{DM}	peak drain current	note 2	–	–1.3	A
P_{tot}	total power dissipation	$T_S = 100\text{ }^\circ\text{C}$	–	4	W
T_{stg}	storage temperature		–65	+150	$^\circ\text{C}$
T_j	operating junction temperature		–65	+150	$^\circ\text{C}$
Source-drain diode					
I_S	source current (DC)	$T_S = 100\text{ }^\circ\text{C}$	–	–0.5	A
I_{SM}	peak pulsed source current	note 2	–	–2	A

Notes

- T_s is the temperature at the soldering point of the drain lead.
- Pulse width and duty cycle limited by maximum junction temperature.

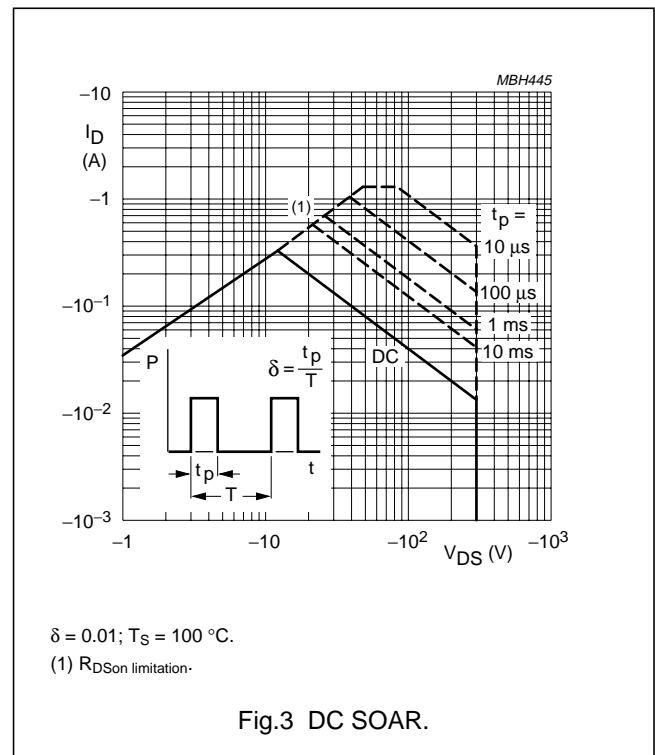
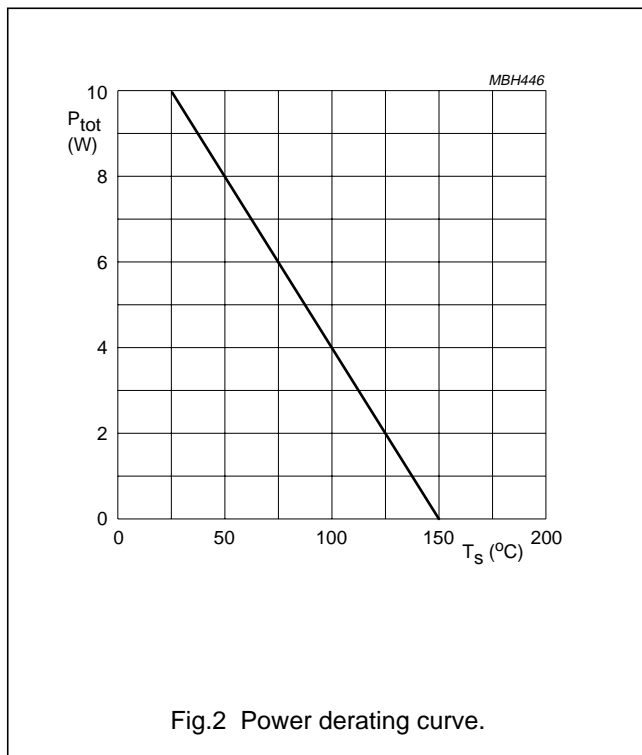

P-channel enhancement mode
vertical D-MOS transistor

BSP255

THERMAL CHARACTERISTICS

SYMBOL	PARAMETER	VALUE	UNIT
$R_{th\ j-s}$	thermal resistance from junction to soldering point	12	K/W

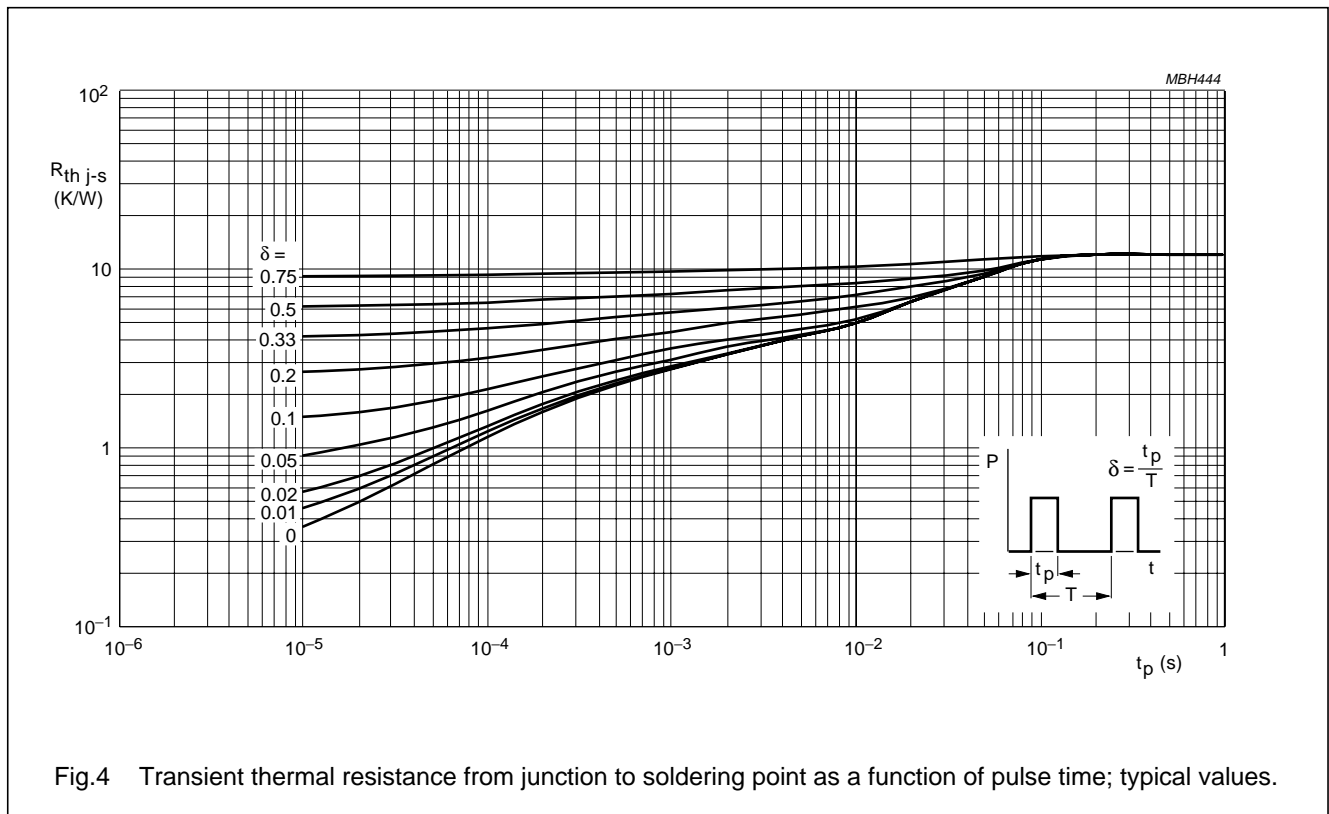

Fig.4 Transient thermal resistance from junction to soldering point as a function of pulse time; typical values.

P-channel enhancement mode vertical D-MOS transistor

BSP255

CHARACTERISTICST_j = 25 °C unless otherwise specified.

SYMBOL	PARAMETER	CONDITIONS	MIN.	TYP.	MAX.	UNIT
V _{(BR)DSS}	drain-source breakdown voltage	V _{GS} = 0; I _D = -10 μA	-300	-	-	V
V _{GSth}	gate-source threshold voltage	V _{GS} = V _{DS} ; I _D = -1 mA	-0.8	-	-2	V
I _{DSS}	drain-source leakage current	V _{GS} = 0; V _{DS} = -240 V	-	-	-100	nA
I _{GSS}	gate leakage current	V _{GS} = ±20 V; V _{DS} = 0	-	-	±100	nA
R _{DSon}	drain-source on-state resistance	V _{GS} = -10 V; I _D = -160 mA	-	-	17	Ω
		V _{GS} = -4.5 V; I _D = -80 mA	-	-	20	Ω
		V _{GS} = -2.8 V; I _D = -50 mA	-	-	25	Ω
C _{iss}	input capacitance	V _{GS} = 0; V _{DS} = -50 V; f = 1 MHz	-	45	-	pF
C _{oss}	output capacitance	V _{GS} = 0; V _{DS} = -50 V; f = 1 MHz	-	15	-	pF
C _{rss}	reverse transfer capacitance	V _{GS} = 0; V _{DS} = -50 V; f = 1 MHz	-	3	-	pF
Q _g	total gate charge	V _{GS} = -10 V; V _{DD} = -50 V; I _D = -160 mA; T _{amb} = 25 °C	-	2.3	-	nC
Q _{gs}	gate-source charge	V _{GS} = -10 V; V _{DD} = -50 V; I _D = -160 mA; T _{amb} = 25 °C	-	0.1	-	nC
Q _{gd}	gate-drain charge	V _{GS} = -10 V; V _{DD} = -50 V; I _D = -160 mA; T _{amb} = 25 °C	-	0.7	-	nC
Switching times (see Fig.11)						
t _{d(on)}	turn-on delay time	V _{GS} = 0 to -10 V; V _{DD} = -50 V; I _D = -160 mA; R _{gen} = 50 Ω	-	2.4	-	ns
t _r	rise time		-	1.6	-	ns
t _{on}	turn-on switching time		-	4	-	ns
t _{d(off)}	turn-off delay time	V _{GS} = -10 to 0 V; V _{DD} = -50 V; I _D = -160 mA; R _{gen} = 50 Ω	-	13	-	ns
t _f	fall time		-	12	-	ns
t _{off}	turn-off switching time		-	25	-	ns
Source-drain diode						
V _{SD}	source-drain forward voltage	V _{GD} = 0; I _S = -0.5 A	-	-	-1.8	V

P-channel enhancement mode vertical D-MOS transistor

BSP255

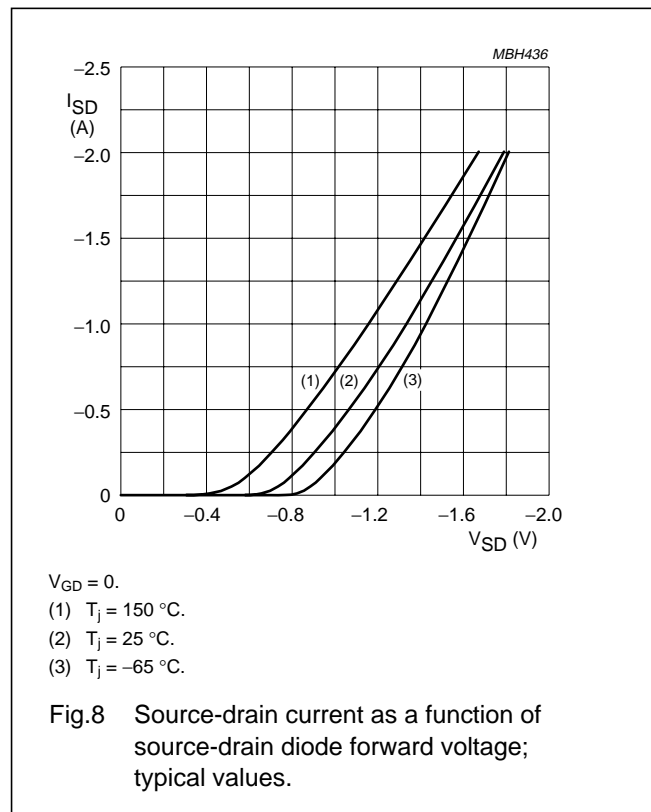
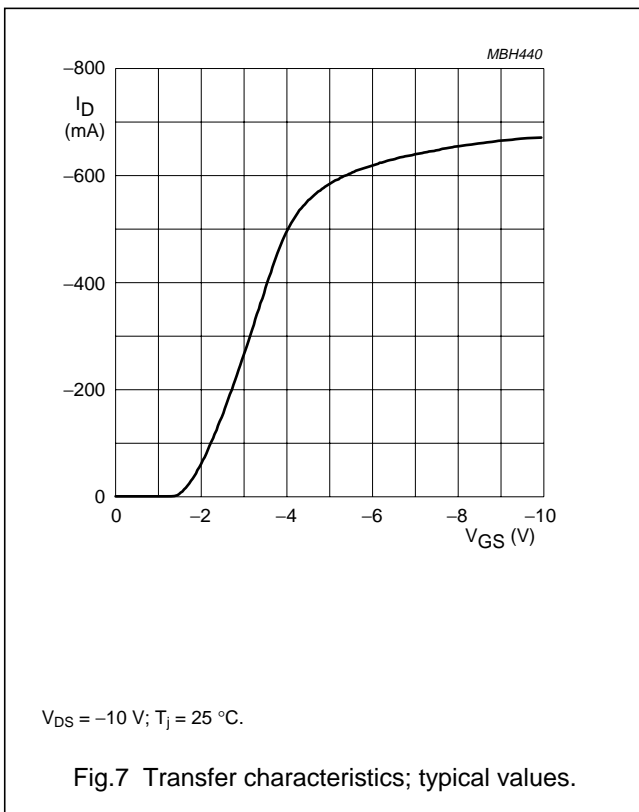
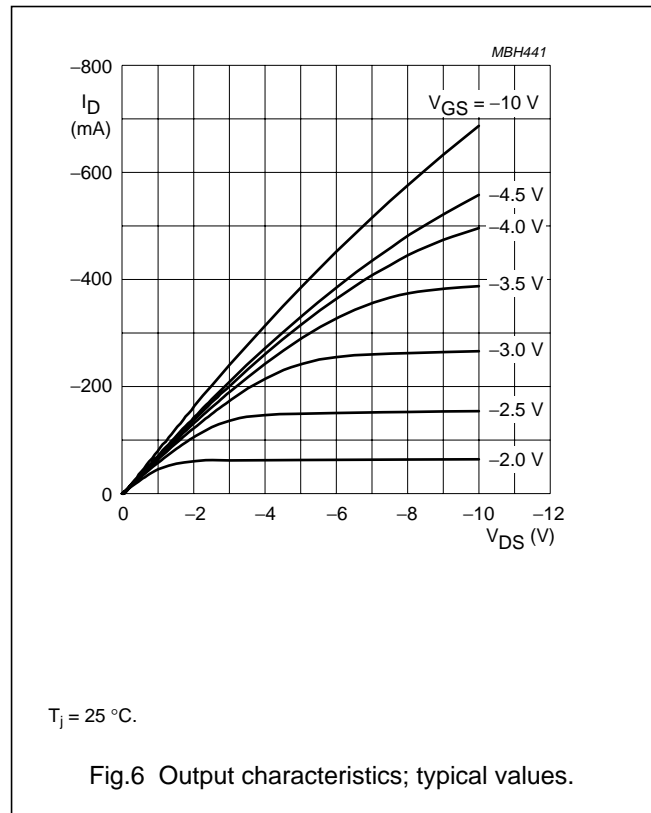
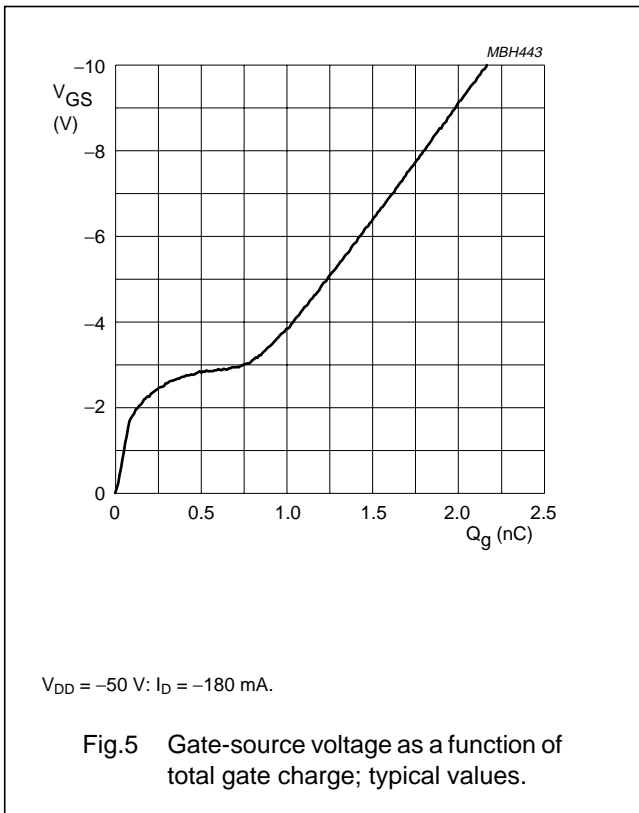

P-channel enhancement mode vertical D-MOS transistor

BSP255

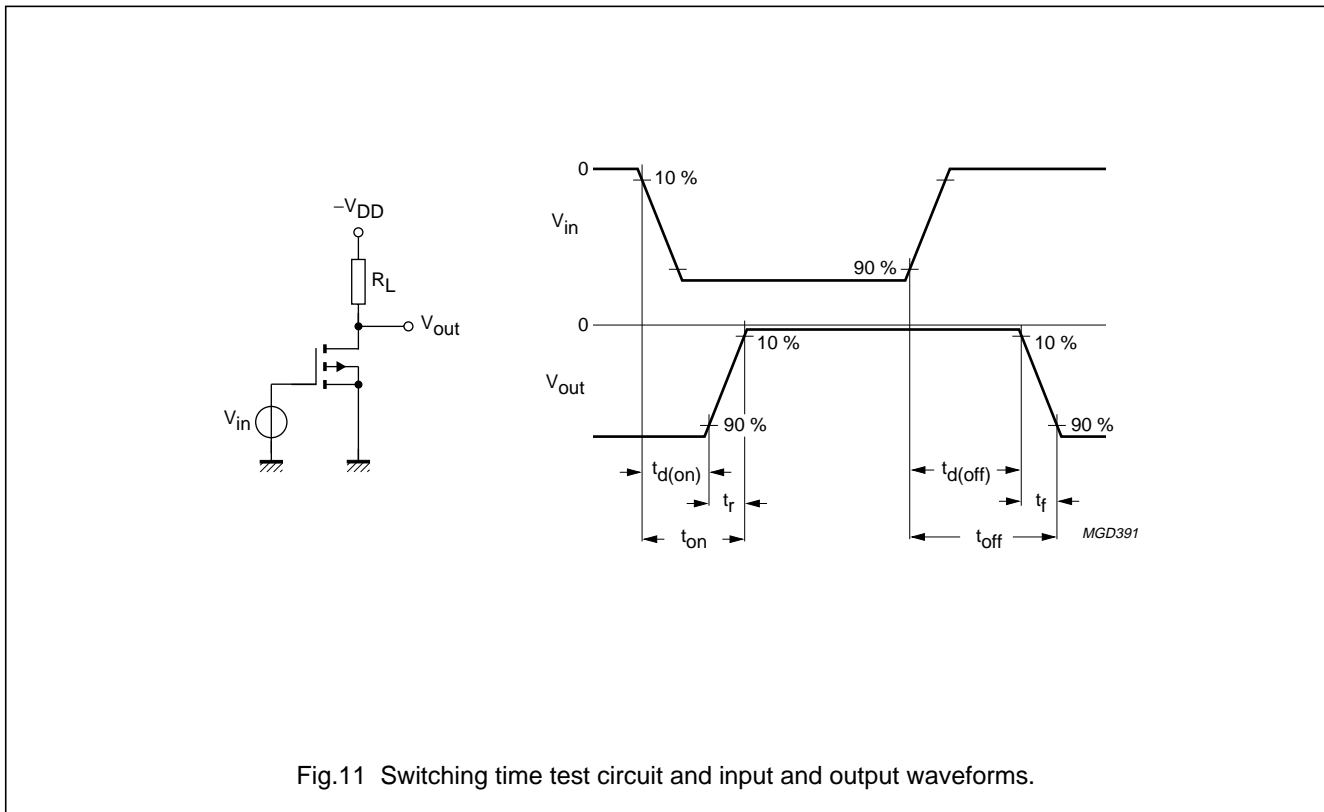
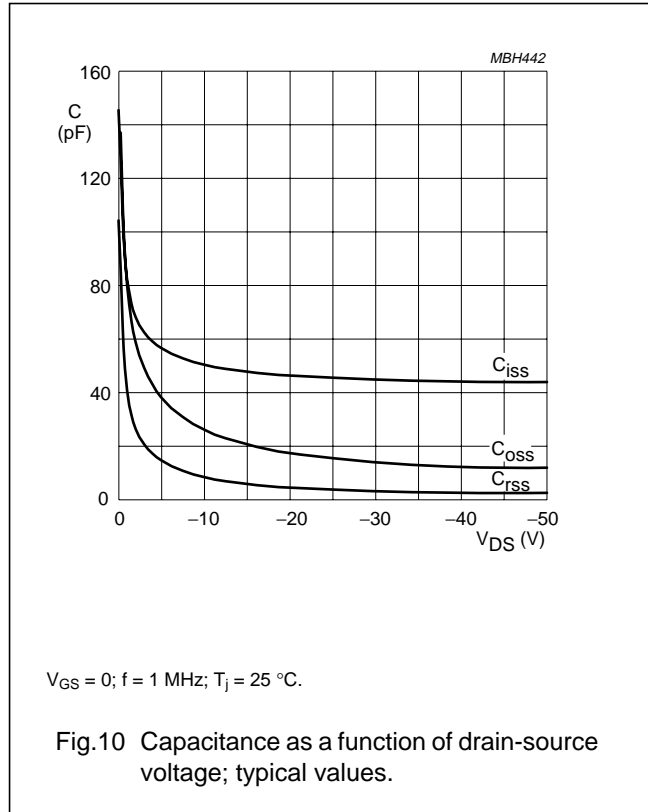
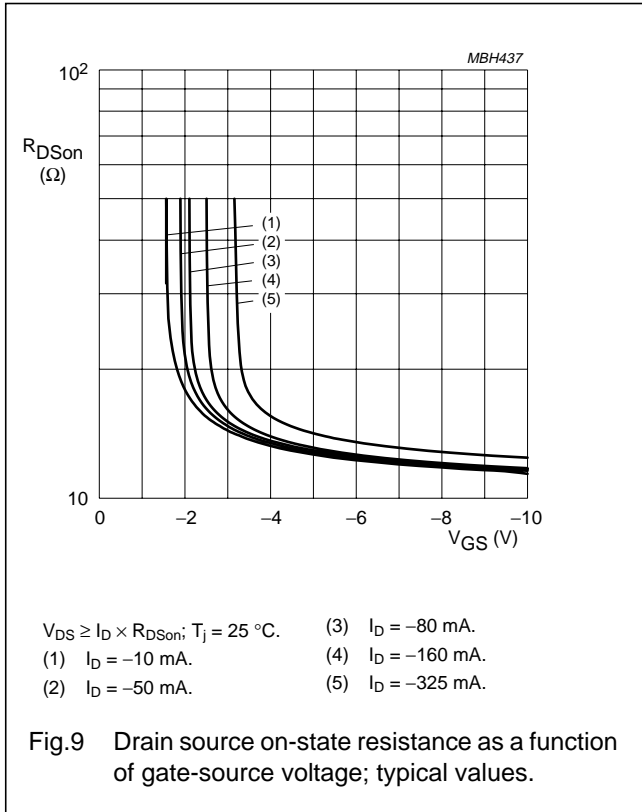

P-channel enhancement mode
vertical D-MOS transistor

BSP255

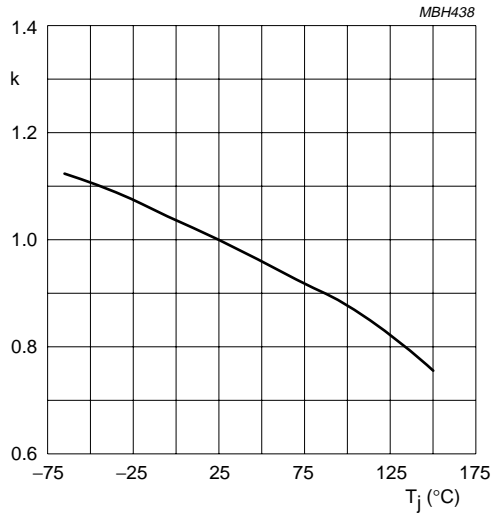

$$k = \frac{V_{GSth} \text{ at } T_j}{V_{GSth} \text{ at } 25^\circ\text{C}}$$

V_{GSth} at V_{DS} = V_{GS}; I_D = -1 mA.

Fig.12 Temperature coefficient of gate-source threshold voltage as a function of junction temperature; typical values.

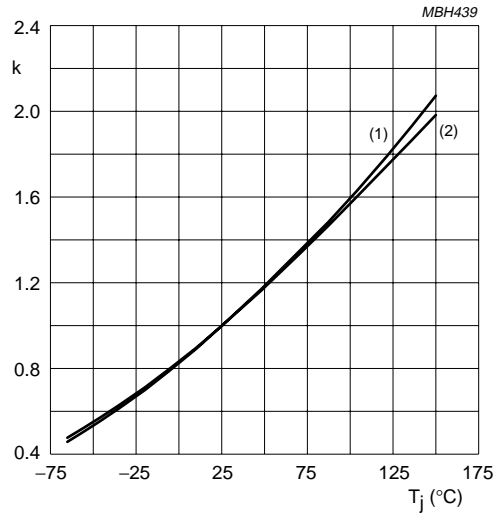

$$k = \frac{R_{DSon} \text{ at } T_j}{R_{DSon} \text{ at } 25^\circ\text{C}}$$

(1) V_{GS} = -4.5 V; I_D = -80 mA.

(2) V_{GS} = -2.8 V; I_D = -50 mA.

Fig.13 Temperature coefficient of drain-source on-state resistance as a function of junction temperature; typical values.

P-channel enhancement mode
vertical D-MOS transistor

BSP255

PACKAGE OUTLINE

Plastic surface mounted package; collector pad for good heat transfer; 4 leads

SOT223

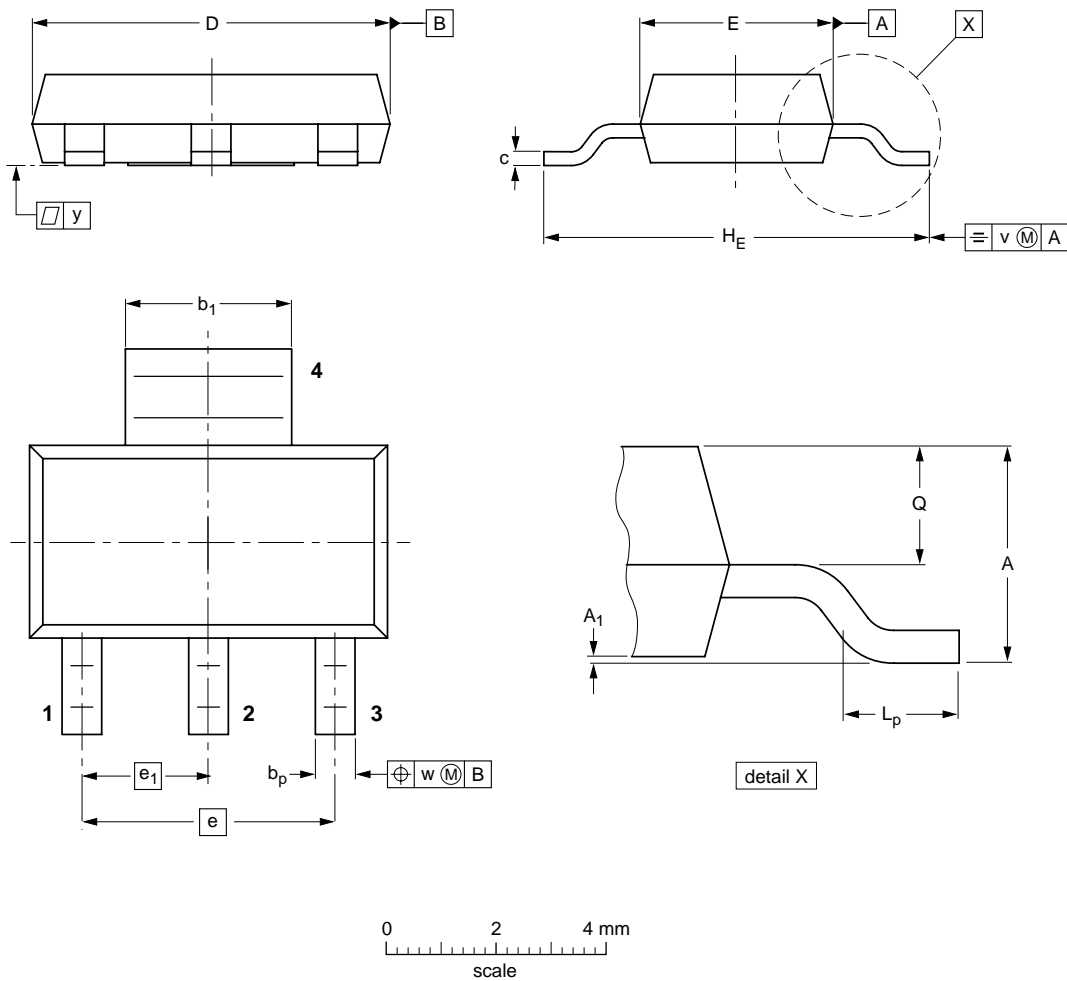

DIMENSIONS (mm are the original dimensions)

UNIT	A	A ₁	b _p	b ₁	c	D	E	e	e ₁	H _E	L _p	Q	v	w	y
mm	1.8 1.5	0.10 0.01	0.80 0.60	3.1 2.9	0.32 0.22	6.7 6.3	3.7 3.3	4.6	2.3	7.3 6.7	1.1 0.7	0.95 0.85	0.2	0.1	0.1

OUTLINE VERSION	REFERENCES				EUROPEAN PROJECTION	ISSUE DATE
	IEC	JEDEC	EIAJ			
SOT223						96-11-11 97-02-28

**P-channel enhancement mode
vertical D-MOS transistor**

BSP255**DEFINITIONS**

Data Sheet Status	
Objective specification	This data sheet contains target or goal specifications for product development.
Preliminary specification	This data sheet contains preliminary data; supplementary data may be published later.
Product specification	This data sheet contains final product specifications.
Limiting values	
Limiting values given are in accordance with the Absolute Maximum Rating System (IEC 134). Stress above one or more of the limiting values may cause permanent damage to the device. These are stress ratings only and operation of the device at these or at any other conditions above those given in the Characteristics sections of the specification is not implied. Exposure to limiting values for extended periods may affect device reliability.	
Application information	
Where application information is given, it is advisory and does not form part of the specification.	

LIFE SUPPORT APPLICATIONS

These products are not designed for use in life support appliances, devices, or systems where malfunction of these products can reasonably be expected to result in personal injury. Philips customers using or selling these products for use in such applications do so at their own risk and agree to fully indemnify Philips for any damages resulting from such improper use or sale.



LittleDiode supplies new, hard to find or obsolete electronic components and semiconductors all over the world.

With over two million different components listed you are sure to find the part you need.

Feel free to visit us today at our online store:

LittleDiode.com

Looking forward to providing you with the best possible service.