

DATA SHEET

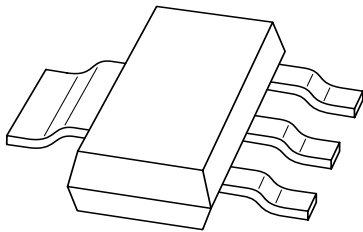

BAT120

Schottky barrier double diodes

Product specification
Supersedes data of 1998 Oct 30

2001 Aug 27

Schottky barrier double diodes

BAT120

FEATURES

- Low switching losses
- Capability of absorbing very high surge current
- Fast recovery time
- Guard ring protected
- Plastic SMD package.

APPLICATIONS

- Low power switched-mode power supplies
- Rectification
- Polarity protection.

DESCRIPTION

Planar Schottky barrier double diodes encapsulated in a SOT223 plastic SMD package

MARKING

TYPE NUMBER	MARKING CODE
BAT120A	AT120A
BAT120C	AT120C
BAT120S	AT120S

PINNING

PIN	BAT120		
	A	C	S
1	k ₁	a ₁	a ₁
2	n.c.	n.c.	n.c.
3	k ₂	a ₂	k ₂
4	a ₁ , a ₂	k ₁ , k ₂	k ₁ , a ₂

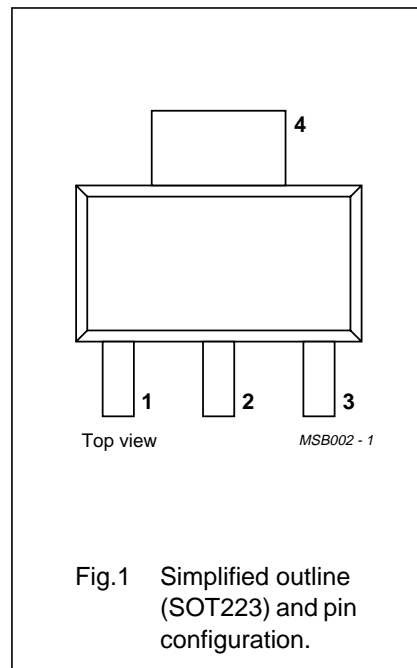

Fig.1 Simplified outline (SOT223) and pin configuration.

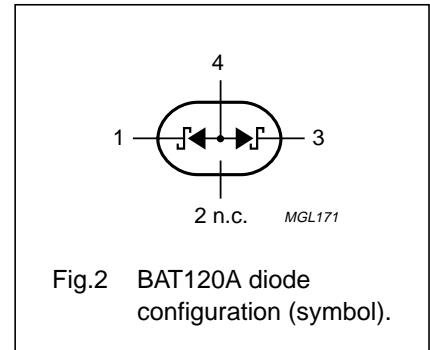

Fig.2 BAT120A diode configuration (symbol).

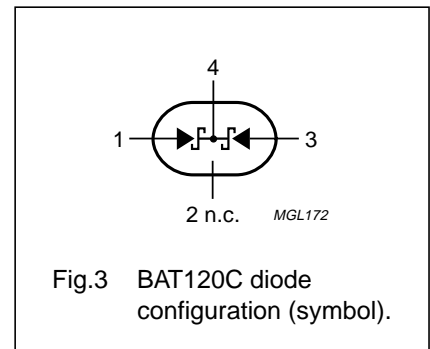

Fig.3 BAT120C diode configuration (symbol).

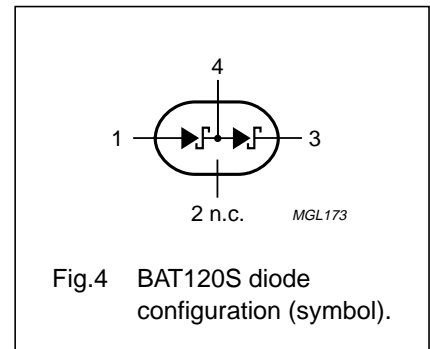

Fig.4 BAT120S diode configuration (symbol).

Schottky barrier double diodes

BAT120

LIMITING VALUES

In accordance with the Absolute Maximum Rating System (IEC 60134).

SYMBOL	PARAMETER	CONDITIONS	MIN.	MAX.	UNIT
Per diode					
V_R	continuous reverse voltage		–	25	V
I_F	continuous forward current		–	1	A
I_{FSM}	non-repetitive peak forward current	$t_p < 10$ ms; half sinewave; JEDEC method	–	10	A
I_{RSM}	non-repetitive peak reverse current	$t_p = 100$ μ s	–	0.5	A
T_{stg}	storage temperature		–65	+150	°C
T_j	junction temperature		–	125	°C
T_{amb}	operating ambient temperature		–65	+125	°C

ELECTRICAL CHARACTERISTICS $T_{amb} = 25$ °C unless otherwise specified.

SYMBOL	PARAMETER	CONDITIONS	TYP.	MAX.	UNIT
Per diode					
V_F	forward voltage	see Fig.5			
		$I_F = 100$ mA	260	300	mV
I_R	reverse current	$I_F = 1$ A	400	450	mV
		$V_R = 20$ V; note 1; see Fig.6	80	500	μ A
		$V_R = 25$ V; note 1; see Fig.6	–	1	mA
C_d	diode capacitance	$V_R = 20$ V; $T_j = 100$ °C; note 1	–	10	mA
		$f = 1$ MHz; $V_R = 4$ V; see Fig.7	100	–	pF

Note1. Pulse test: $t_p = 300$ μ s; $\delta = 0.02$.**THERMAL CHARACTERISTICS**

SYMBOL	PARAMETER	CONDITIONS	VALUE	UNIT
$R_{th\ j-a}$	thermal resistance from junction to ambient	note 1	100	K/W

Note

1. Refer to SOT223 standard mounting conditions.

Schottky barrier double diodes

BAT120

GRAPHICAL DATA

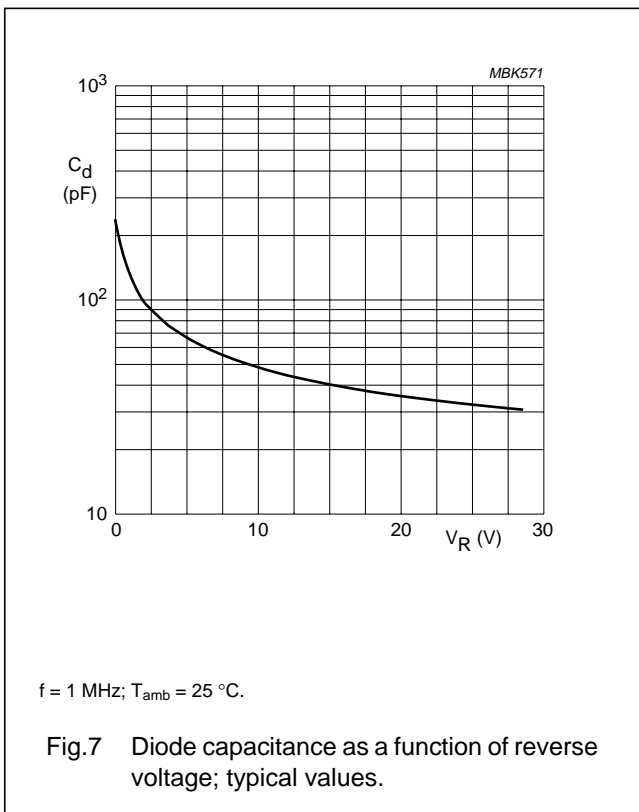
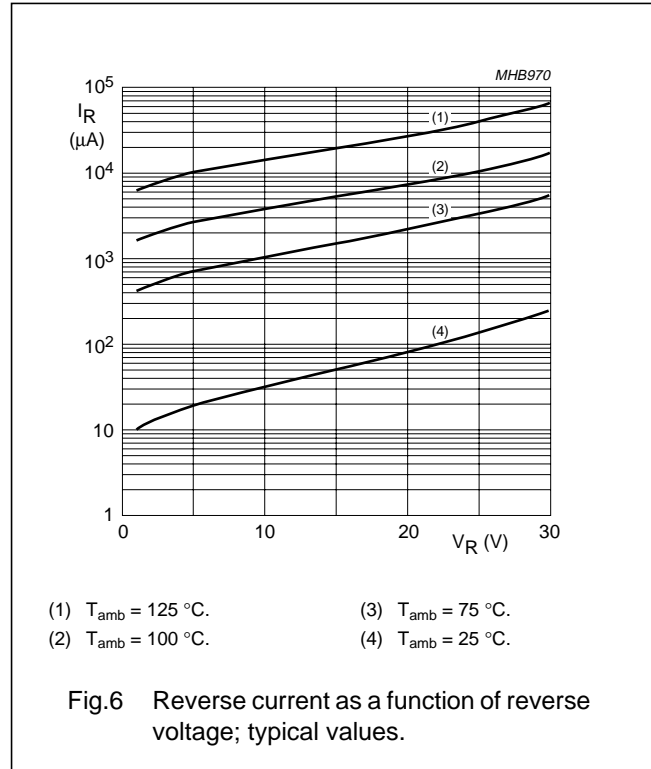
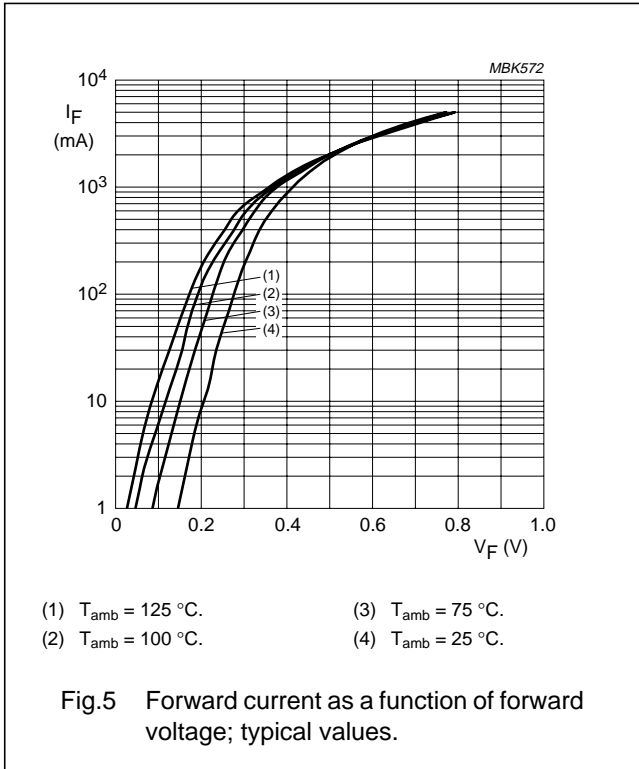

Schottky barrier double diodes

BAT120

PACKAGE OUTLINE

Plastic surface mounted package; collector pad for good heat transfer; 4 leads

SOT223

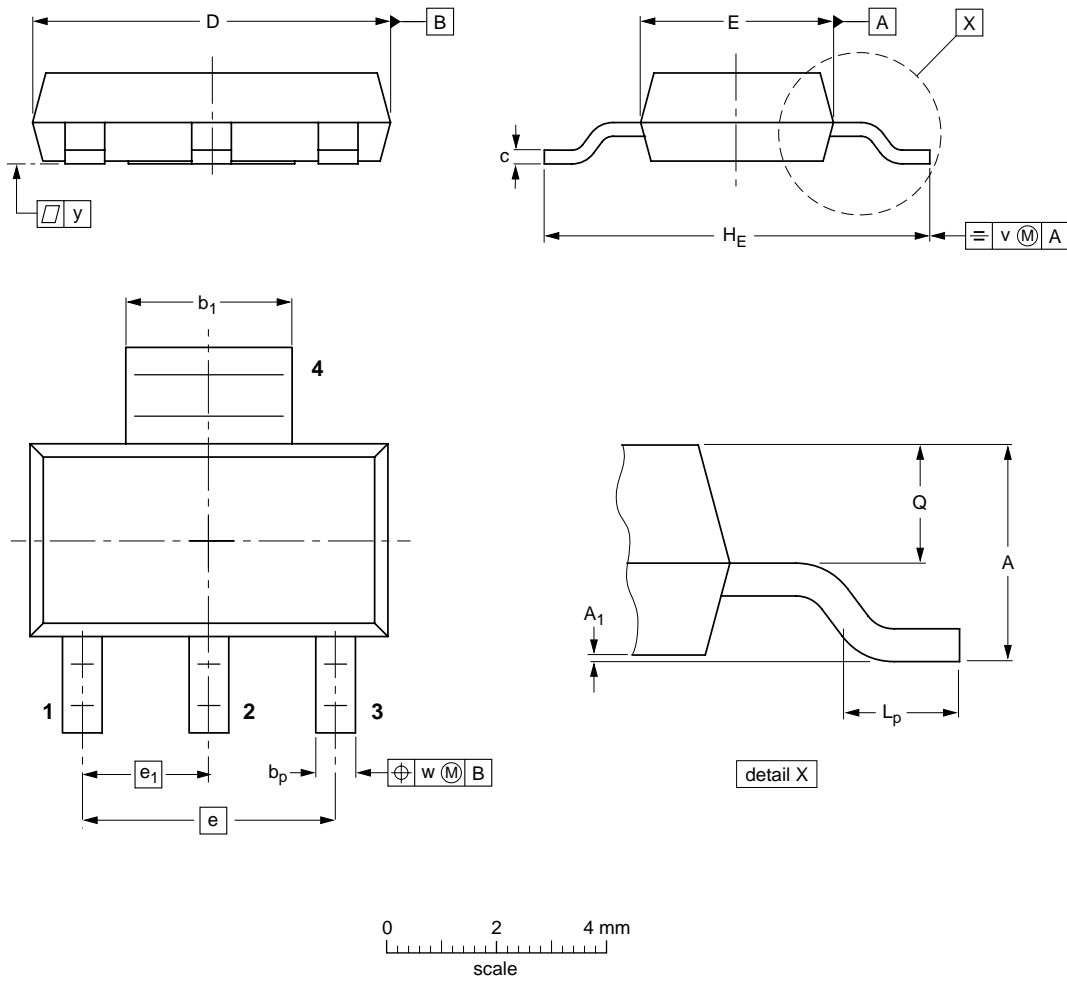

DIMENSIONS (mm are the original dimensions)

UNIT	A	A ₁	b _p	b ₁	c	D	E	e	e ₁	H _E	L _p	Q	v	w	y
mm	1.8	0.10	0.80	3.1	0.32	6.7	3.7	4.6	2.3	7.3	1.1	0.95	0.2	0.1	0.1
	1.5	0.01	0.60	2.9	0.22	6.3	3.3			6.7	0.7	0.85			

OUTLINE VERSION	REFERENCES				EUROPEAN PROJECTION	ISSUE DATE
	IEC	JEDEC	EIAJ			
SOT223			SC-73			97-02-28 99-09-13

Schottky barrier double diodes

BAT120

DATA SHEET STATUS

DATA SHEET STATUS ⁽¹⁾	PRODUCT STATUS ⁽²⁾	DEFINITIONS
Objective data	Development	This data sheet contains data from the objective specification for product development. Philips Semiconductors reserves the right to change the specification in any manner without notice.
Preliminary data	Qualification	This data sheet contains data from the preliminary specification. Supplementary data will be published at a later date. Philips Semiconductors reserves the right to change the specification without notice, in order to improve the design and supply the best possible product.
Product data	Production	This data sheet contains data from the product specification. Philips Semiconductors reserves the right to make changes at any time in order to improve the design, manufacturing and supply. Changes will be communicated according to the Customer Product/Process Change Notification (CPCN) procedure SNW-SQ-650A.

Notes

1. Please consult the most recently issued data sheet before initiating or completing a design.
2. The product status of the device(s) described in this data sheet may have changed since this data sheet was published. The latest information is available on the Internet at URL <http://www.semiconductors.philips.com>.

DEFINITIONS

Short-form specification — The data in a short-form specification is extracted from a full data sheet with the same type number and title. For detailed information see the relevant data sheet or data handbook.

Limiting values definition — Limiting values given are in accordance with the Absolute Maximum Rating System (IEC 60134). Stress above one or more of the limiting values may cause permanent damage to the device. These are stress ratings only and operation of the device at these or at any other conditions above those given in the Characteristics sections of the specification is not implied. Exposure to limiting values for extended periods may affect device reliability.

Application information — Applications that are described herein for any of these products are for illustrative purposes only. Philips Semiconductors make no representation or warranty that such applications will be suitable for the specified use without further testing or modification.

DISCLAIMERS

Life support applications — These products are not designed for use in life support appliances, devices, or systems where malfunction of these products can reasonably be expected to result in personal injury. Philips Semiconductors customers using or selling these products for use in such applications do so at their own risk and agree to fully indemnify Philips Semiconductors for any damages resulting from such application.

Right to make changes — Philips Semiconductors reserves the right to make changes, without notice, in the products, including circuits, standard cells, and/or software, described or contained herein in order to improve design and/or performance. Philips Semiconductors assumes no responsibility or liability for the use of any of these products, conveys no licence or title under any patent, copyright, or mask work right to these products, and makes no representations or warranties that these products are free from patent, copyright, or mask work right infringement, unless otherwise specified.

Schottky barrier double diodes

BAT120

NOTES

Philips Semiconductors – a worldwide company

Contact information

For additional information please visit <http://www.semiconductors.philips.com>. Fax: +31 40 27 24825

For sales offices addresses send e-mail to: sales.addresses@www.semiconductors.philips.com.

© Koninklijke Philips Electronics N.V. 2001

SCA73

All rights are reserved. Reproduction in whole or in part is prohibited without the prior written consent of the copyright owner.

The information presented in this document does not form part of any quotation or contract, is believed to be accurate and reliable and may be changed without notice. No liability will be accepted by the publisher for any consequence of its use. Publication thereof does not convey nor imply any license under patent- or other industrial or intellectual property rights.

Printed in The Netherlands

613510/03/pp8

Date of release: 2001 Aug 27

Document order number: 9397 750 08658

Let's make things better.

**Philips
Semiconductors**



PHILIPS



LittleDiode supplies new, hard to find or obsolete electronic components and semiconductors all over the world.

With over two million different components listed you are sure to find the part you need.

Feel free to visit us today at our online store:

LittleDiode.com

Looking forward to providing you with the best possible service.