

Silicon Diffused Power Transistor

BUT11AI

GENERAL DESCRIPTION

Enhanced performance, high speed switching npn transistor in TO220AB envelope specially suited for high frequency electronic lighting ballast applications and converters, inverters, switching regulators, motor control systems etc.

QUICK REFERENCE DATA

SYMBOL	PARAMETER	CONDITIONS	TYP.	MAX.	UNIT
V_{CESM}	Collector-emitter voltage peak value	$V_{BE} = 0\text{ V}$	-	1000	V
V_{CEO}	Collector-emitter voltage (open base)		-	450	V
I_C	Collector current (DC)		-	5	A
I_{CM}	Collector current peak value		-	10	A
P_{tot}	Total power dissipation	$T_{mb} \leq 25\text{ °C}$	-	100	W
V_{CEsat}	Collector-emitter saturation voltage	$I_C = 2.5\text{ A}; I_B = 0.33\text{ A}$	-	1.5	V
I_{Csat}	Collector Saturation current		2.5		A
t_f	Inductive fall time	$I_{Con} = 2.5\text{ A}; I_{Bon} = 0.5\text{ A}$	0.08	0.15	μs

PINNING - TO220AB

PIN	DESCRIPTION
1	base
2	collector
3	emitter
tab	collector

PIN CONFIGURATION

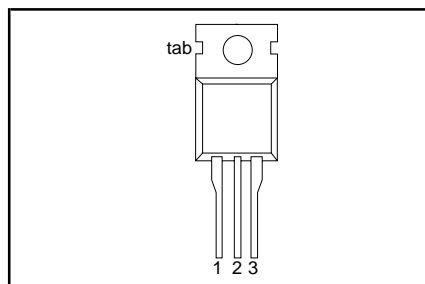

SYMBOL

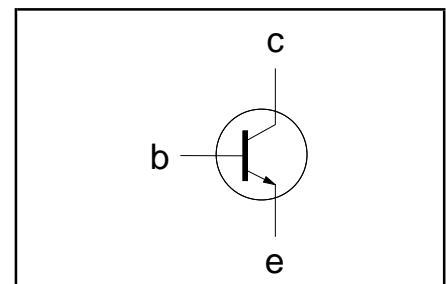

LIMITING VALUES

Limiting values in accordance with the Absolute Maximum Rating System (IEC 134)

SYMBOL	PARAMETER	CONDITIONS	MIN.	MAX.	UNIT
V_{CESM}	Collector-emitter voltage peak value	$V_{BE} = 0\text{ V}$	-	1000	V
V_{CEO}	Collector-emitter voltage (open base)		-	450	V
I_C	Collector current (DC)		-	5	A
I_{CM}	Collector current peak value		-	10	A
I_B	Base current (DC)		-	2	A
I_{BM}	Base current peak value		-	4	A
P_{tot}	Total power dissipation	$T_{mb} \leq 25\text{ °C}$	-	100	W
T_{stg}	Storage temperature		-65	150	$^{\circ}\text{C}$
T_j	Junction temperature		-	150	$^{\circ}\text{C}$

THERMAL RESISTANCES

SYMBOL	PARAMETER	CONDITIONS	TYP.	MAX.	UNIT
$R_{th\ j-mb}$	Junction to mounting base		-	1.25	K/W
$R_{th\ j-a}$	Junction to ambient	in free air	-	60	K/W

Silicon Diffused Power Transistor

BUT11AI

STATIC CHARACTERISTICS

$T_{mb} = 25\text{ }^\circ\text{C}$ unless otherwise specified

SYMBOL	PARAMETER	CONDITIONS	MIN.	TYP.	MAX.	UNIT
I_{CES}	Collector cut-off current ¹	$V_{BE} = 0\text{ V}; V_{CE} = V_{CESMmax}$	-	-	1.0	mA
I_{CES}		$V_{BE} = 0\text{ V}; V_{CE} = V_{CESMmax}$	-	-	2.0	mA
I_{EBO}	Emitter cut-off current	$V_{EB} = 9.0\text{ V}; I_C = 0\text{ A}$	-	-	10.0	mA
$V_{CEOsust}$	Collector-emitter sustaining voltage	$I_B = 0\text{ A}; I_C = 100\text{ mA}; L = 25\text{ mH}$	450	-	-	V
V_{CEsat}	Collector-emitter saturation voltage	$I_C = 2.5\text{ A}; I_B = 0.33\text{ A}$	-	-	1.5	V
V_{BEsat}	Base-emitter saturation voltage	$I_C = 2.5\text{ A}; I_B = 0.33\text{ A}$	-	-	1.3	V
h_{FE}	DC current gain	$I_C = 5\text{ mA}; V_{CE} = 5\text{ V}$	10	20	35	
h_{FE}		$I_C = 0.5\text{ A}; V_{CE} = 5\text{ V}$	14	22	35	
h_{FEsat}		$I_C = 2.5\text{ A}; V_{CE} = 5\text{ V}$	9	13	17	

DYNAMIC CHARACTERISTICS

$T_{mb} = 25\text{ }^\circ\text{C}$ unless otherwise specified

SYMBOL	PARAMETER	CONDITIONS	TYP.	MAX.	UNIT
t_{on}	Switching times resistive load Turn-on time	$I_{Con} = 2.5\text{ A}; I_{Bon} = 0.5\text{ A}; -I_{Boff} = 0.5\text{ A}$	0.6	1.0	μs
t_s	Turn-off storage time		3.4	4.0	μs
t_f	Turn-off fall time		0.6	0.8	μs
	Switching times inductive load	$I_{Con} = 2.5\text{ A}; I_{Bon} = 0.5\text{ A}; L_B = 1\text{ }\mu\text{H}; -V_{BB} = 5\text{ V}$			
t_s	Turn-off storage time		1.1	1.4	μs
t_f	Turn-off fall time		80	150	ns
t_s	Turn-off storage time	$I_{Con} = 2.5\text{ A}; I_{Bon} = 0.5\text{ A}; L_B = 1\text{ }\mu\text{H}; -V_{BB} = 5\text{ V}; T_j = 100\text{ }^\circ\text{C}$	1.2	1.5	μs
t_f	Turn-off fall time		140	300	ns

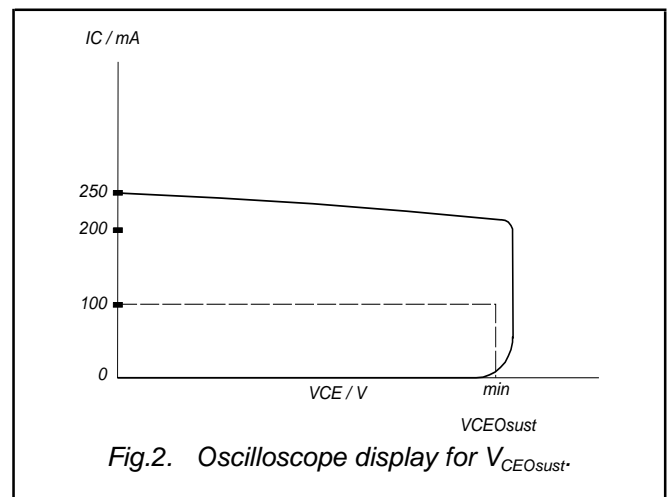
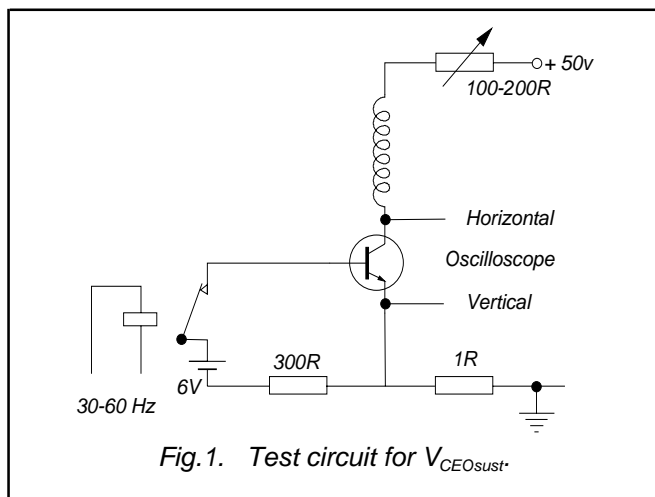

¹ Measured with half sine-wave voltage (curve tracer).

Silicon Diffused Power Transistor

BUT11AI

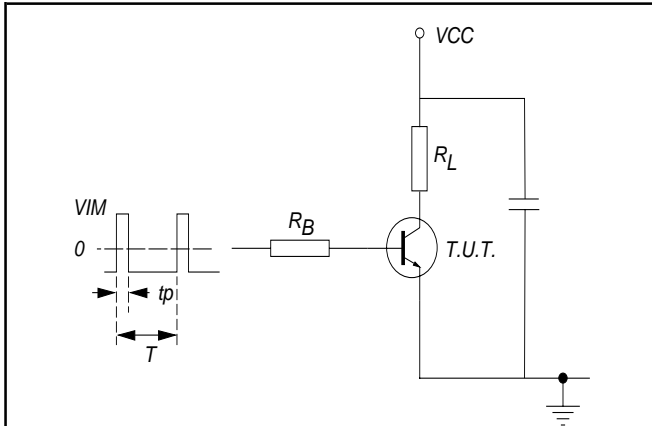

Fig.3. Test circuit resistive load. $V_{IM} = -6$ to $+8$ V
 $V_{CC} = 250$ V; $t_p = 20 \mu s$; $\delta = t_p / T = 0.01$.
 R_B and R_L calculated from I_{Con} and I_{Bon} requirements.

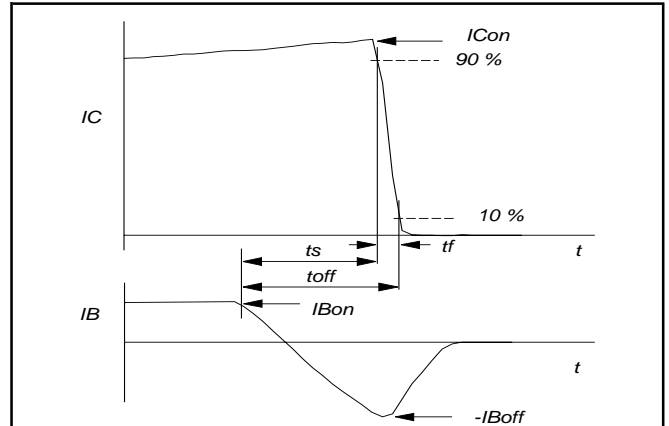

Fig.6. Switching times waveforms with inductive load.

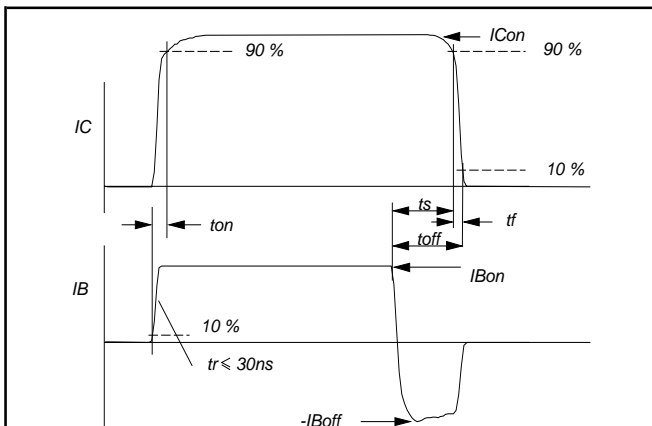

Fig.4. Switching times waveforms with resistive load.

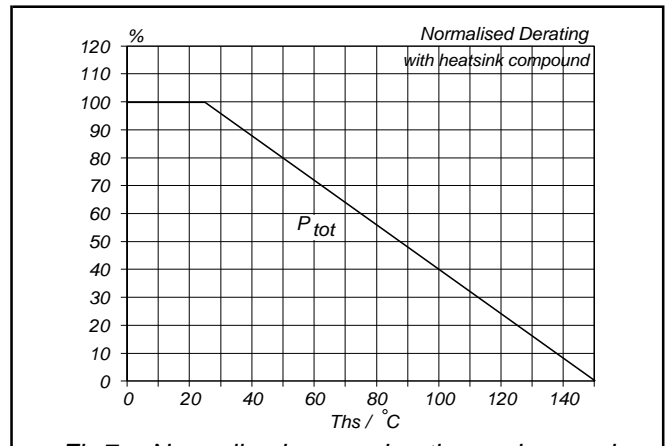

Fig.7. Normalised power derating and second breakdown curves.

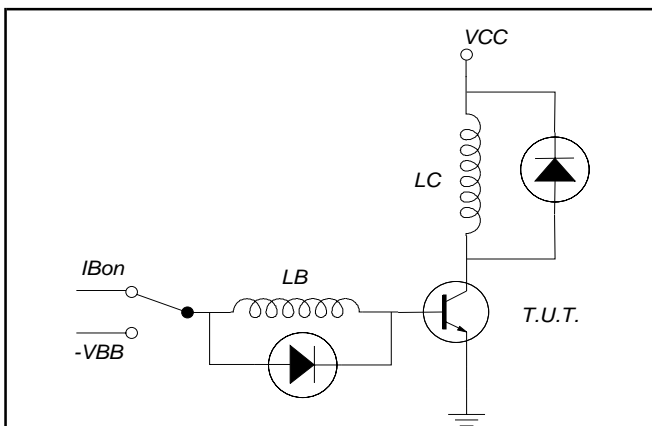

Fig.5. Test circuit inductive load.
 $V_{CC} = 300$ V; $-V_{BE} = 5$ V; $L_C = 200 \mu H$; $L_B = 1 \mu H$

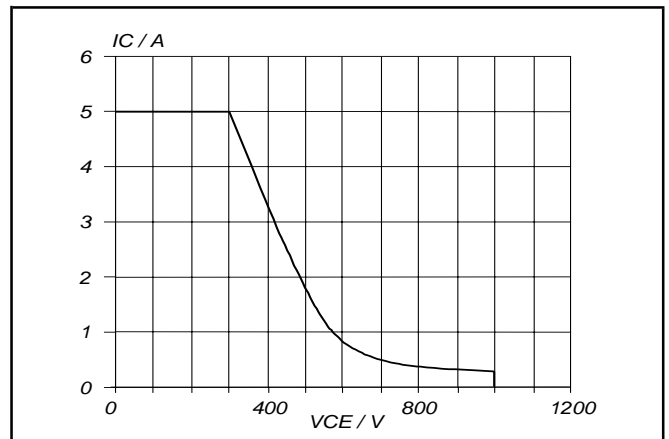

Fig.8. Reverse bias safe operating area. $T_j \leq T_{jmax}$

Silicon Diffused Power Transistor

BUT11AI

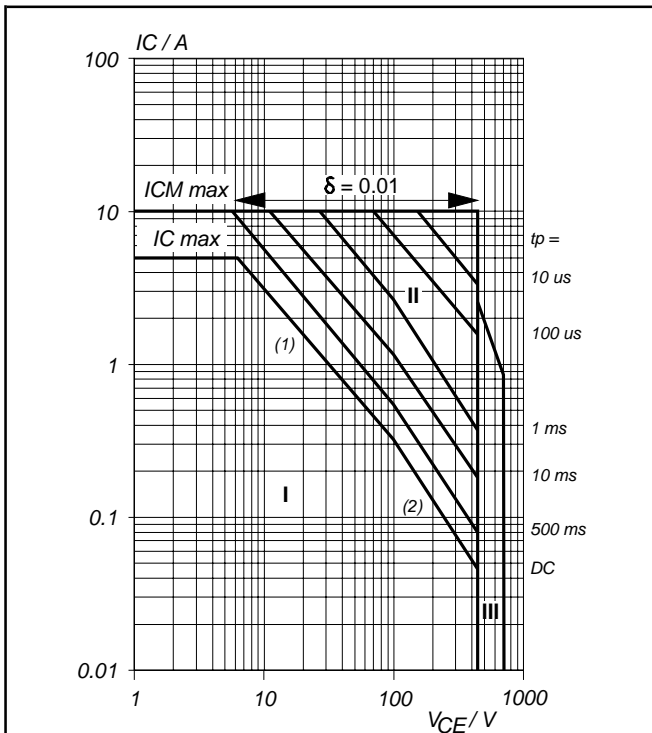
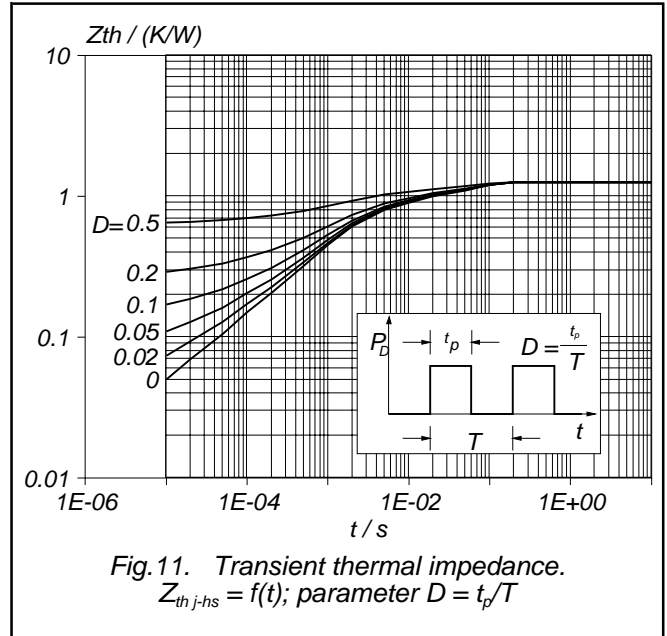
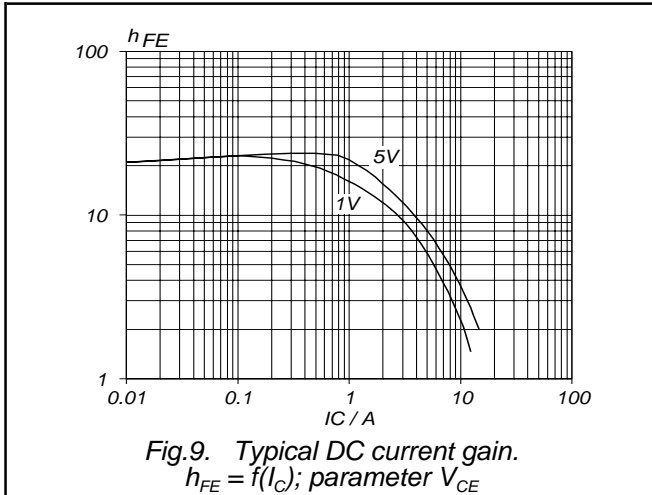

Fig.10. Forward bias safe operating area. $T_{hs} \leq 25\text{ }^\circ C$

- (1) P_{tot} max and P_{tot} peak max lines.
 - (2) Second breakdown limits.
 - I Region of permissible DC operation.
 - II Extension for repetitive pulse operation.
 - III Extension during turn-on in single transistor converters provided that $R_{BE} \leq 100\ \Omega$ and $t_p \leq 0.6\ \mu s$.
- NB: Mounted with heatsink compound and 30 ± 5 newton force on the centre of the envelope.

Silicon Diffused Power Transistor

BUT11AI

MECHANICAL DATA

Dimensions in mm

Net Mass: 2 g

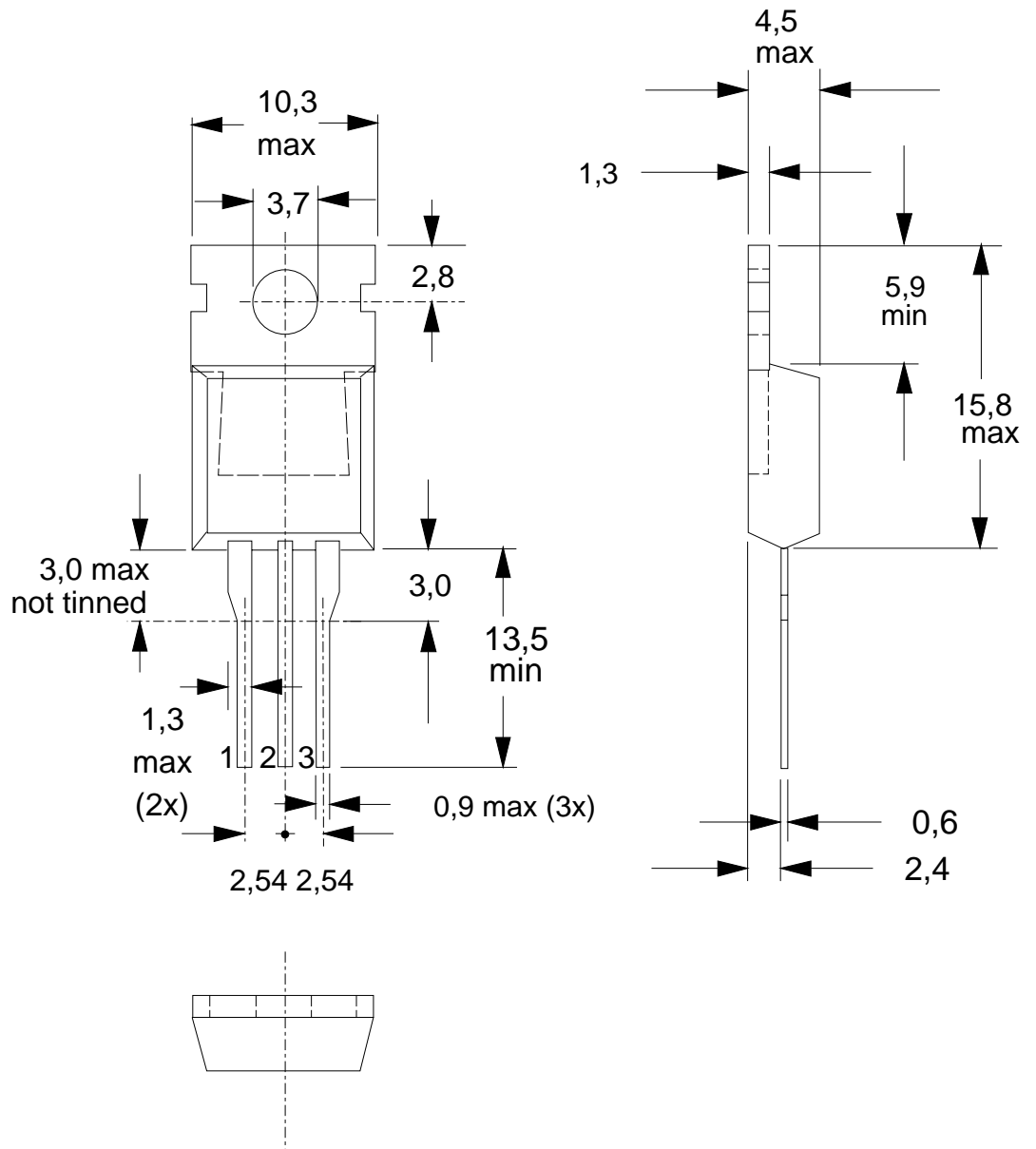

Fig.12. TO220AB; pin 2 connected to mounting base.

Notes

1. Refer to mounting instructions for TO220 envelopes.
2. Epoxy meets UL94 V0 at 1/8".

Silicon Diffused Power Transistor

BUT11AI

DEFINITIONS

DATA SHEET STATUS		
DATA SHEET STATUS²	PRODUCT STATUS³	DEFINITIONS
Objective data	Development	This data sheet contains data from the objective specification for product development. Philips Semiconductors reserves the right to change the specification in any manner without notice
Preliminary data	Qualification	This data sheet contains data from the preliminary specification. Supplementary data will be published at a later date. Philips Semiconductors reserves the right to change the specification without notice, in order to improve the design and supply the best possible product
Product data	Production	This data sheet contains data from the product specification. Philips Semiconductors reserves the right to make changes at any time in order to improve the design, manufacturing and supply. Changes will be communicated according to the Customer Product/Process Change Notification (CPCN) procedure SNW-SQ-650A
Limiting values		
Limiting values are given in accordance with the Absolute Maximum Rating System (IEC 134). Stress above one or more of the limiting values may cause permanent damage to the device. These are stress ratings only and operation of the device at these or at any other conditions above those given in the Characteristics sections of this specification is not implied. Exposure to limiting values for extended periods may affect device reliability.		
Application information		
Where application information is given, it is advisory and does not form part of the specification.		
© Philips Electronics N.V. 2002		
All rights are reserved. Reproduction in whole or in part is prohibited without the prior written consent of the copyright owner.		
The information presented in this document does not form part of any quotation or contract, it is believed to be accurate and reliable and may be changed without notice. No liability will be accepted by the publisher for any consequence of its use. Publication thereof does not convey nor imply any license under patent or other industrial or intellectual property rights.		

LIFE SUPPORT APPLICATIONS

These products are not designed for use in life support appliances, devices or systems where malfunction of these products can be reasonably expected to result in personal injury. Philips customers using or selling these products for use in such applications do so at their own risk and agree to fully indemnify Philips for any damages resulting from such improper use or sale.

² Please consult the most recently issued datasheet before initiating or completing a design.

³ The product status of the device(s) described in this datasheet may have changed since this datasheet was published. The latest information is available on the Internet at URL <http://www.semiconductors.philips.com>.



LittleDiode supplies new, hard to find or obsolete electronic components and semiconductors all over the world.

With over two million different components listed you are sure to find the part you need.

Feel free to visit us today at our online store:

LittleDiode.com

Looking forward to providing you with the best possible service.