

To all our customers

Regarding the change of names mentioned in the document, such as Hitachi Electric and Hitachi XX, to Renesas Technology Corp.

The semiconductor operations of Mitsubishi Electric and Hitachi were transferred to Renesas Technology Corporation on April 1st 2003. These operations include microcomputer, logic, analog and discrete devices, and memory chips other than DRAMs (flash memory, SRAMs etc.) Accordingly, although Hitachi, Hitachi, Ltd., Hitachi Semiconductors, and other Hitachi brand names are mentioned in the document, these names have in fact all been changed to Renesas Technology Corp. Thank you for your understanding. Except for our corporate trademark, logo and corporate statement, no changes whatsoever have been made to the contents of the document, and these changes do not constitute any alteration to the contents of the document itself.

Renesas Technology Home Page: <http://www.renesas.com>

Renesas Technology Corp.
Customer Support Dept.
April 1, 2003

Cautions

Keep safety first in your circuit designs!

1. Renesas Technology Corporation puts the maximum effort into making semiconductor products better and more reliable, but there is always the possibility that trouble may occur with them. Trouble with semiconductors may lead to personal injury, fire or property damage.

Remember to give due consideration to safety when making your circuit designs, with appropriate measures such as (i) placement of substitutive, auxiliary circuits, (ii) use of nonflammable material or (iii) prevention against any malfunction or mishap.

Notes regarding these materials

1. These materials are intended as a reference to assist our customers in the selection of the Renesas Technology Corporation product best suited to the customer's application; they do not convey any license under any intellectual property rights, or any other rights, belonging to Renesas Technology Corporation or a third party.
2. Renesas Technology Corporation assumes no responsibility for any damage, or infringement of any third-party's rights, originating in the use of any product data, diagrams, charts, programs, algorithms, or circuit application examples contained in these materials.
3. All information contained in these materials, including product data, diagrams, charts, programs and algorithms represents information on products at the time of publication of these materials, and are subject to change by Renesas Technology Corporation without notice due to product improvements or other reasons. It is therefore recommended that customers contact Renesas Technology Corporation or an authorized Renesas Technology Corporation product distributor for the latest product information before purchasing a product listed herein.
The information described here may contain technical inaccuracies or typographical errors. Renesas Technology Corporation assumes no responsibility for any damage, liability, or other loss rising from these inaccuracies or errors.
Please also pay attention to information published by Renesas Technology Corporation by various means, including the Renesas Technology Corporation Semiconductor home page (<http://www.renesas.com>).
4. When using any or all of the information contained in these materials, including product data, diagrams, charts, programs, and algorithms, please be sure to evaluate all information as a total system before making a final decision on the applicability of the information and products. Renesas Technology Corporation assumes no responsibility for any damage, liability or other loss resulting from the information contained herein.
5. Renesas Technology Corporation semiconductors are not designed or manufactured for use in a device or system that is used under circumstances in which human life is potentially at stake. Please contact Renesas Technology Corporation or an authorized Renesas Technology Corporation product distributor when considering the use of a product contained herein for any specific purposes, such as apparatus or systems for transportation, vehicular, medical, aerospace, nuclear, or undersea repeater use.
6. The prior written approval of Renesas Technology Corporation is necessary to reprint or reproduce in whole or in part these materials.
7. If these products or technologies are subject to the Japanese export control restrictions, they must be exported under a license from the Japanese government and cannot be imported into a country other than the approved destination.
Any diversion or reexport contrary to the export control laws and regulations of Japan and/or the country of destination is prohibited.
8. Please contact Renesas Technology Corporation for further details on these materials or the products contained therein.

2SC5820

Silicon NPN Epitaxial High Frequency Low Noise Amplifier / Oscillator

RENESAS

ADE-208-1604A (Z)

Rev.1
Nov. 2002

Features

- High gain bandwidth product
 $f_T = 20$ GHz typ.
- High power gain and low noise figure;
PG = 17.5 dB typ., NF = 1.15 dB typ. at $f = 1.8$ GHz

Outline

CMPAK-4

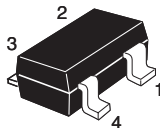

1. Emitter
2. Collector
3. Emitter
4. Base

Note: Marking is "WU-".

Absolute Maximum Ratings

(Ta = 25 °C)

Item	Symbol	Ratings	Unit
Collector to base voltage	V_{CBO}	12	V
Collector to emitter voltage	V_{CEO}	4.0	V
Emitter to base voltage	V_{EBO}	1.5	V
Collector current	I_C	35	mA
Collector power dissipation	Pc	100	mW
Junction temperature	Tj	150	°C
Storage temperature	Tstg	-55 to +150	°C

Electrical Characteristics

(Ta = 25°C)

Item	Symbol	Min	Typ	Max	Unit	Test conditions
Collector cutoff current	I_{CBO}	—	—	1	μA	$V_{CB} = 12\text{ V}, I_E = 0$
Collector cutoff current	I_{CEO}	—	—	1	μA	$V_{CE} = 4\text{ V}, R_{BE} = \infty$
Emitter cutoff current	I_{EBO}	—	—	10	μA	$V_{EB} = 1.5\text{ V}, I_C = 0$
DC current transfer ratio	h_{FE}	70	110	150	—	$V_{CE} = 2\text{ V}, I_C = 20\text{ mA}$
Collector output capacitance	C_{ob}	—	0.3	0.6	pF	$V_{CB} = 2\text{ V}, I_E = 0, f = 1\text{ MHz}$
Gain bandwidth product	f_T	17	20	—	GHz	$V_{CE} = 2\text{ V}, I_C = 30\text{ mA}$ $f = 2\text{ GHz}$
Power gain	PG	13	17.5	—	dB	$V_{CE} = 2\text{ V}, I_C = 30\text{ mA},$ $f = 1.8\text{ GHz}$
Noise figure	NF	—	1.15	1.7	dB	$V_{CE} = 2\text{ V}, I_C = 5\text{ mA},$ $f = 1.8\text{ GHz}$
3rd. Order Intercept Point	IP3	—	10	—	dBm	$V_{CE} = 2\text{ V}, I_C = 5\text{ mA},$ $f = 1.8\text{ GHz}$

Collector Power Dissipation Curve

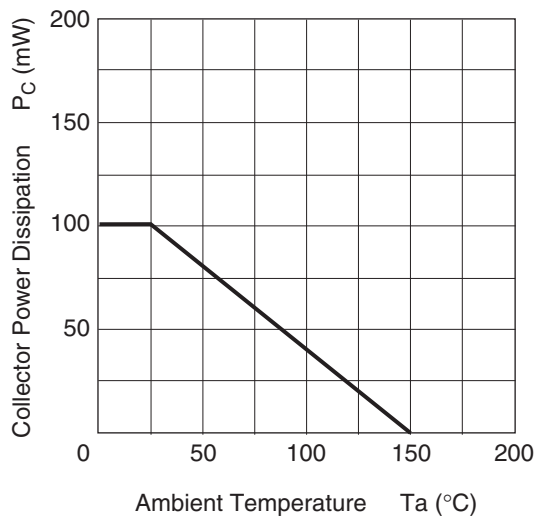

Typical Output Characteristics

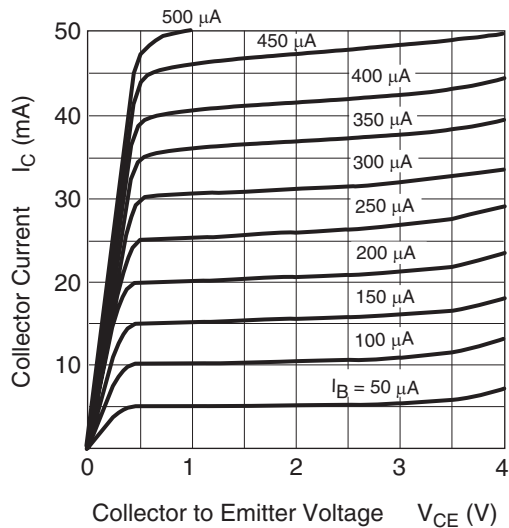

Typical Transfer Characteristics

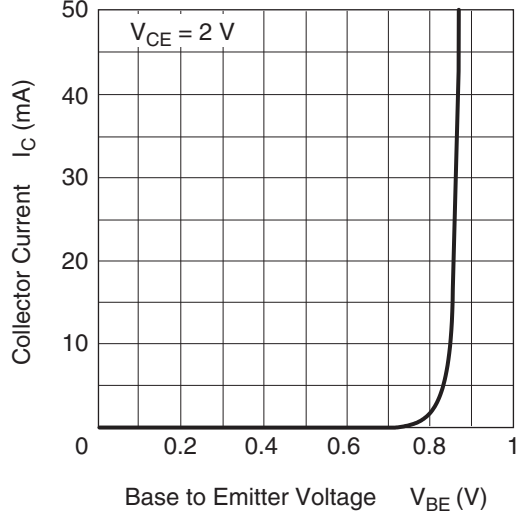

DC Current Transfer Ratio vs. Collector Current

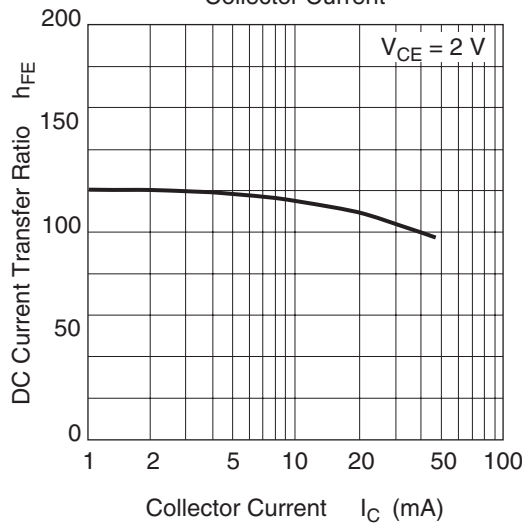

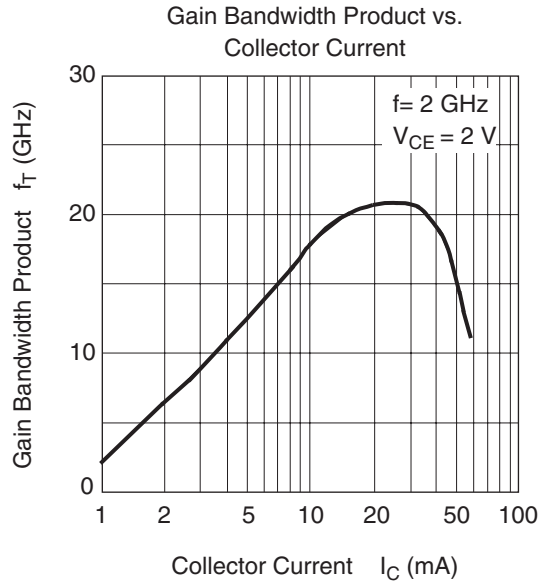
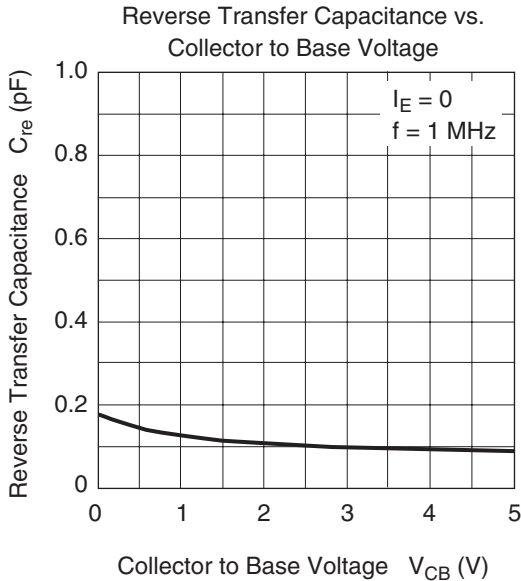
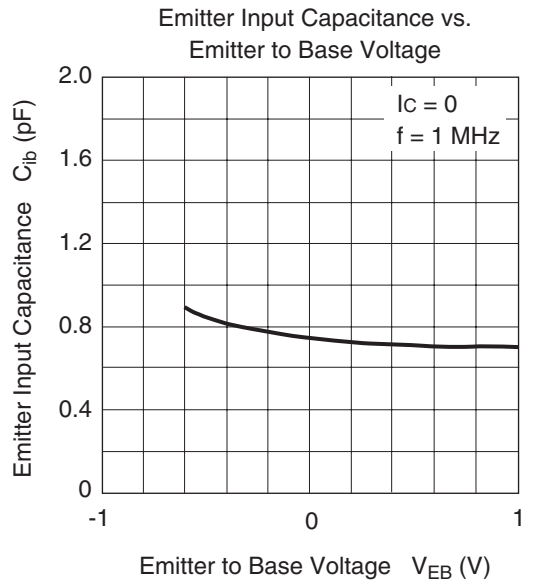
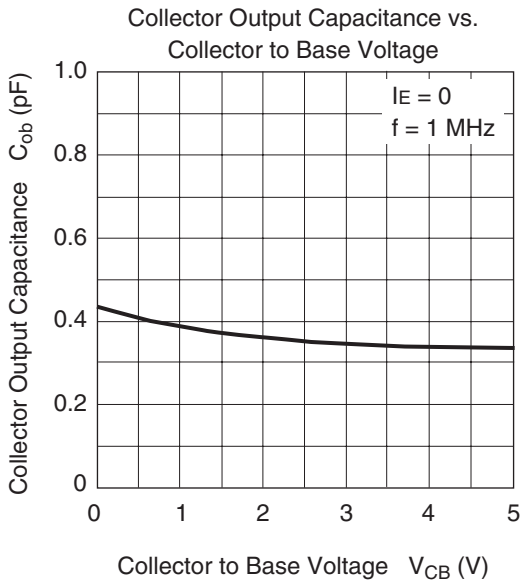

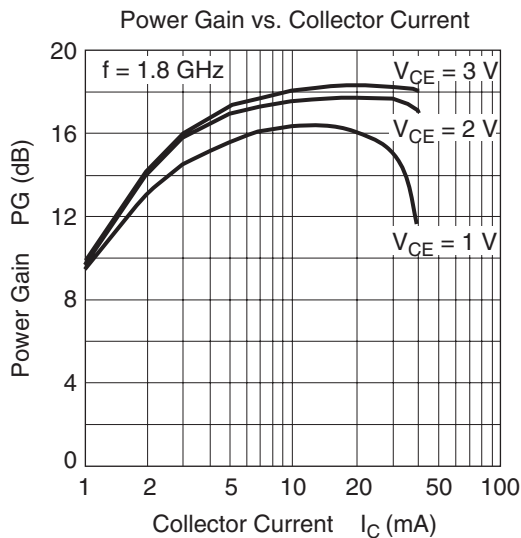
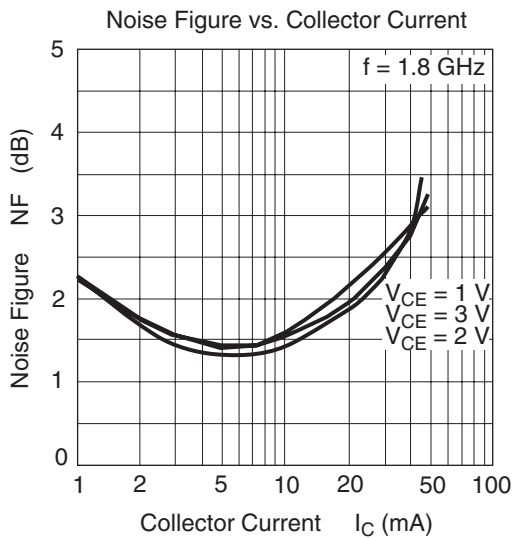
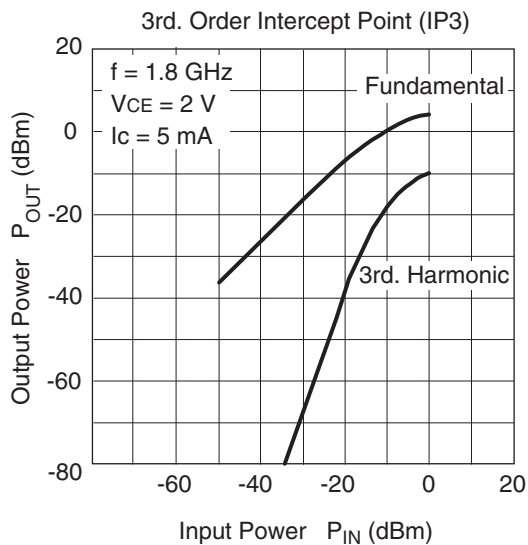
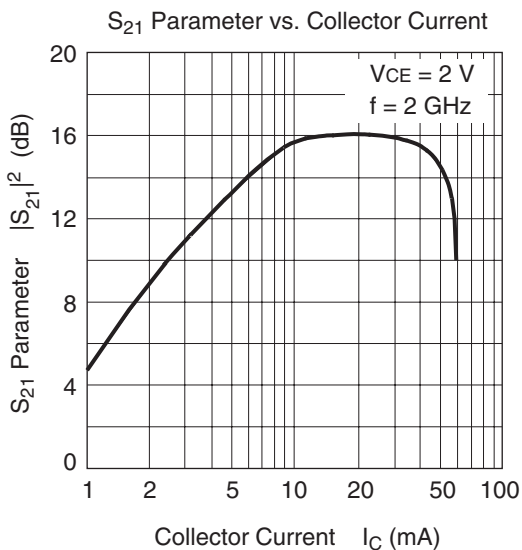

S₁₁ Parameter vs. Frequency

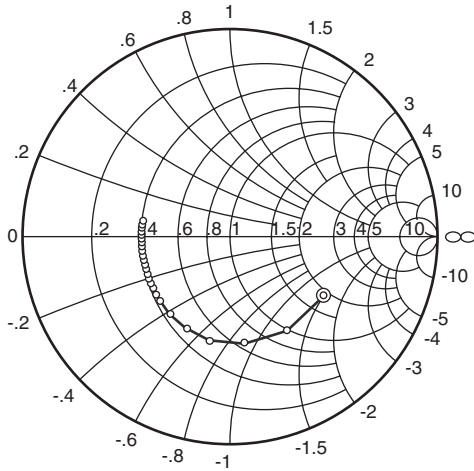

Condition: $V_{CE} = 2\text{ V}$, $Z_O = 50\ \Omega$
 100 to 3000 MHz (100 MHz Step)
 ⊙—○ ($I_C = 30\text{ mA}$)

S₂₁ Parameter vs. Frequency

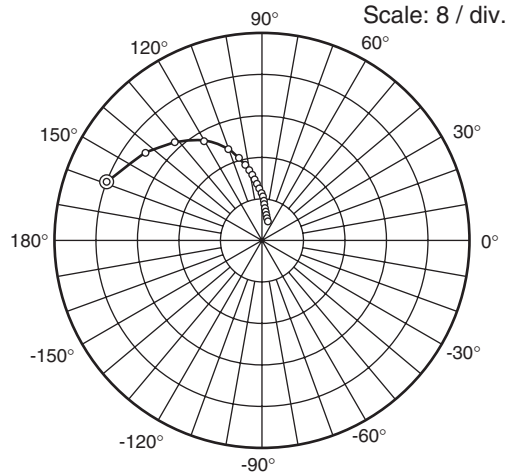

Condition: $V_{CE} = 2\text{ V}$, $Z_O = 50\ \Omega$
 100 to 3000 MHz (100 MHz Step)
 ⊙—○ ($I_C = 30\text{ mA}$)

S₁₂ Parameter vs. Frequency

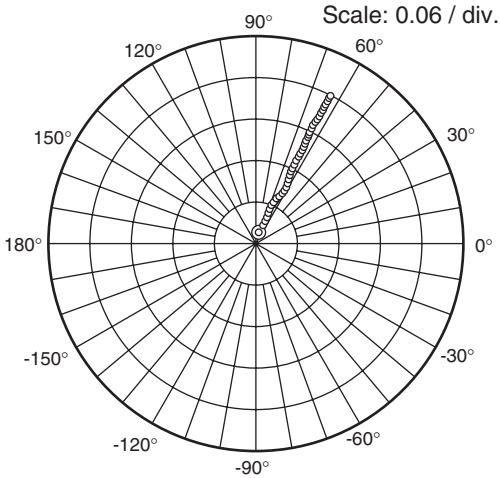

Condition: $V_{CE} = 2\text{ V}$, $Z_O = 50\ \Omega$
 100 to 3000 MHz (100 MHz Step)
 ⊙—○ ($I_C = 30\text{ mA}$)

S₂₂ Parameter vs. Frequency

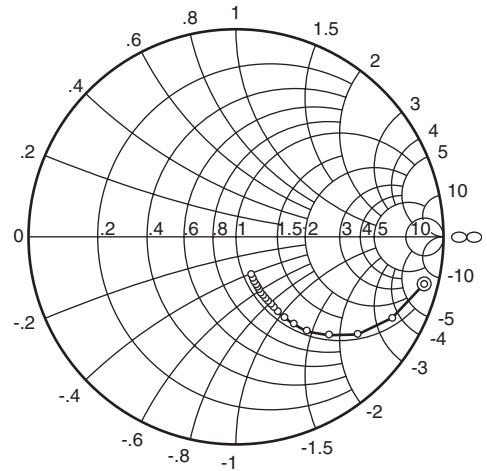

Condition: $V_{CE} = 2\text{ V}$, $Z_O = 50\ \Omega$
 100 to 3000 MHz (100 MHz Step)
 ⊙—○ ($I_C = 30\text{ mA}$)

S Parameter

($V_{CE} = 2\text{ V}$, $I_C = 5\text{ mA}$, $Z_O = 50\ \Omega$)

f (MHz)	S11		S21		S12		S22	
	MAG	ANG	MAG	ANG	MAG	ANG	MAG	ANG
100	0.844	-24.6	15.26	159.9	0.0124	78.9	0.976	-16.4
200	0.835	-23.1	15.07	162.9	0.0153	84.0	0.973	-11.7
300	0.838	-34.2	14.59	154.8	0.0236	80.2	0.953	-17.5
400	0.809	-45.7	13.94	147.1	0.0311	72.5	0.919	-23.6
500	0.781	-56.2	13.16	139.9	0.0387	67.5	0.879	-29.0
600	0.745	-66.8	12.39	133.1	0.0441	61.6	0.828	-33.9
700	0.710	-76.0	11.71	127.7	0.0506	56.2	0.779	-38.6
800	0.688	-85.5	10.89	121.8	0.0537	52.0	0.728	-41.9
900	0.659	-93.5	10.16	117.0	0.0579	47.7	0.682	-45.4
1000	0.639	-101.0	9.47	112.8	0.0610	46.8	0.641	-47.4
1100	0.633	-107.3	8.77	108.6	0.0643	41.1	0.601	-49.8
1200	0.596	-115.4	8.40	105.2	0.0640	40.4	0.560	-51.8
1300	0.578	-121.8	7.92	101.5	0.0665	37.6	0.528	-54.0
1400	0.570	-128.0	7.47	98.3	0.0675	37.4	0.499	-55.4
1500	0.556	-133.1	7.04	95.6	0.0685	32.9	0.473	-57.1
1600	0.548	-138.8	6.68	92.5	0.0691	32.9	0.449	-58.0
1700	0.541	-143.6	6.37	90.1	0.0693	32.5	0.422	-59.0
1800	0.532	-149.0	6.08	87.5	0.0699	30.2	0.400	-60.6
1900	0.529	-153.1	5.77	85.0	0.0716	30.6	0.384	-60.7
2000	0.523	-157.1	5.53	83.2	0.0735	28.8	0.370	-62.1
2100	0.520	-162.0	5.29	80.4	0.0719	30.4	0.349	-62.5
2200	0.521	-164.7	5.03	79.1	0.0733	28.1	0.345	-63.6
2300	0.521	-168.8	4.86	76.4	0.0752	26.6	0.326	-64.0
2400	0.521	-172.0	4.67	74.4	0.0748	26.8	0.312	-64.8
2500	0.520	-175.7	4.53	72.3	0.0752	26.8	0.297	-65.6
2600	0.522	-178.4	4.33	70.6	0.0765	26.2	0.292	-66.7
2700	0.525	178.2	4.21	68.6	0.0771	27.6	0.280	-67.8
2800	0.526	175.6	4.05	67.2	0.0775	27.4	0.275	-68.9
2900	0.529	172.4	3.91	64.8	0.0785	25.5	0.260	-69.5
3000	0.532	169.7	3.82	62.7	0.0772	24.6	0.249	-70.5

2SC5820

($V_{CE} = 2\text{ V}$, $I_C = 10\text{ mA}$, $Z_o = 50\ \Omega$)

f (MHz)	S11		S21		S12		S22	
	MAG	ANG	MAG	ANG	MAG	ANG	MAG	ANG
100	0.717	-17.3	25.92	167.8	0.0073	84.9	0.967	-8.4
200	0.712	-34.2	24.87	156.2	0.0137	81.4	0.941	-17.1
300	0.699	-50.1	23.25	145.5	0.0205	73.7	0.896	-25.1
400	0.667	-65.5	21.32	136.0	0.0266	66.0	0.833	-32.8
500	0.635	-78.9	19.27	127.6	0.0319	62.0	0.766	-39.1
600	0.600	-91.5	17.37	120.5	0.0349	56.4	0.694	-44.3
700	0.572	-102.0	15.73	115.1	0.0403	52.7	0.632	-48.6
800	0.553	-112.1	14.26	109.6	0.0402	51.2	0.574	-51.7
900	0.533	-120.1	12.97	105.3	0.0445	46.0	0.525	-54.8
1000	0.522	-127.4	11.90	101.6	0.0472	47.2	0.484	-56.2
1100	0.515	-133.7	10.90	98.1	0.0476	43.4	0.446	-58.4
1200	0.499	-140.9	10.16	95.3	0.0477	44.4	0.410	-59.4
1300	0.492	-146.8	9.46	92.2	0.0505	43.3	0.381	-61.0
1400	0.490	-152.1	8.84	89.6	0.0509	43.8	0.357	-61.9
1500	0.484	-156.6	8.27	87.4	0.0520	39.7	0.335	-62.9
1600	0.484	-161.3	7.79	84.8	0.0533	41.0	0.316	-63.4
1700	0.482	-165.3	7.38	82.8	0.0540	41.4	0.295	-64.0
1800	0.481	-169.8	6.99	80.7	0.0548	40.0	0.277	-65.0
1900	0.481	-173.1	6.63	78.7	0.0578	41.6	0.265	-65.1
2000	0.481	-176.4	6.33	76.9	0.0601	39.9	0.252	-66.1
2100	0.483	179.9	6.02	74.8	0.0603	42.3	0.238	-66.1
2200	0.484	177.3	5.75	73.4	0.0610	39.9	0.232	-66.9
2300	0.488	174.4	5.52	71.4	0.0641	39.3	0.219	-67.2
2400	0.489	171.8	5.29	69.6	0.0646	39.5	0.209	-67.7
2500	0.491	169.0	5.10	67.8	0.0664	40.2	0.197	-68.0
2600	0.495	166.5	4.89	66.2	0.0678	39.7	0.194	-69.7
2700	0.501	164.3	4.73	64.6	0.0693	40.4	0.185	-71.0
2800	0.503	161.9	4.55	63.2	0.0705	40.2	0.181	-71.9
2900	0.508	159.6	4.39	61.4	0.0715	39.5	0.170	-72.9
3000	0.510	157.3	4.27	59.6	0.0717	37.3	0.162	-74.0

($V_{CE} = 2 \text{ V}$, $I_C = 20 \text{ mA}$, $Z_o = 50 \Omega$)

f (MHz)	S11		S21		S12		S22	
	MAG	ANG	MAG	ANG	MAG	ANG	MAG	ANG
100	0.556	-26.3	38.68	163.4	0.0065	88.2	0.937	-11.6
200	0.550	-50.8	35.60	148.3	0.0117	78.3	0.882	-23.2
300	0.537	-72.0	31.52	135.5	0.0174	71.3	0.805	-32.9
400	0.519	-90.7	27.37	125.0	0.0215	63.3	0.716	-41.4
500	0.501	-105.4	23.66	116.7	0.0252	62.0	0.633	-47.6
600	0.485	-118.3	20.55	110.2	0.0276	57.0	0.556	-52.3
700	0.475	-128.1	18.10	105.3	0.0310	54.2	0.495	-55.9
800	0.470	-137.3	16.09	100.7	0.0312	54.1	0.441	-58.4
900	0.462	-144.3	14.43	97.1	0.0352	51.7	0.397	-60.8
1000	0.460	-150.4	13.12	94.1	0.0369	53.1	0.362	-61.7
1100	0.460	-155.8	11.95	91.2	0.0389	50.4	0.330	-63.6
1200	0.458	-161.4	11.00	88.9	0.0397	52.5	0.302	-63.5
1300	0.457	-166.3	10.20	86.4	0.0425	51.5	0.280	-64.7
1400	0.460	-170.1	9.48	84.2	0.0441	53.3	0.260	-65.2
1500	0.457	-173.9	8.85	82.2	0.0452	49.4	0.242	-66.3
1600	0.462	-177.4	8.31	80.0	0.0469	50.7	0.227	-65.9
1700	0.462	179.3	7.84	78.4	0.0478	52.0	0.210	-66.4
1800	0.466	175.9	7.41	76.6	0.0496	49.7	0.198	-66.8
1900	0.467	173.3	7.02	74.8	0.0532	51.5	0.187	-67.2
2000	0.469	170.6	6.70	73.2	0.0548	50.1	0.178	-67.2
2100	0.474	167.8	6.36	71.4	0.0572	52.8	0.167	-67.3
2200	0.476	165.5	6.09	70.0	0.0574	50.9	0.161	-68.3
2300	0.480	163.3	5.82	68.3	0.0610	48.6	0.152	-68.2
2400	0.483	161.2	5.58	66.7	0.0616	49.0	0.143	-69.2
2500	0.486	159.0	5.37	65.0	0.0638	49.8	0.135	-69.8
2600	0.490	156.9	5.15	63.4	0.0661	48.6	0.131	-70.8
2700	0.497	155.3	4.97	62.1	0.0699	48.9	0.123	-72.9
2800	0.499	153.1	4.78	60.8	0.0715	49.3	0.122	-74.1
2900	0.505	151.4	4.61	59.2	0.0714	48.0	0.114	-75.4
3000	0.506	149.6	4.48	57.6	0.0713	46.7	0.106	-77.2

2SC5820

($V_{CE} = 2\text{ V}$, $I_C = 30\text{ mA}$, $Z_o = 50\ \Omega$)

f (MHz)	S11		S21		S12		S22	
	MAG	ANG	MAG	ANG	MAG	ANG	MAG	ANG
100	0.441	-34.8	45.76	160.6	0.0061	84.2	0.913	-13.6
200	0.449	-65.1	40.75	143.5	0.0110	78.8	0.838	-26.7
300	0.455	-88.7	34.81	129.9	0.0153	69.4	0.741	-37.1
400	0.455	-107.9	29.32	119.4	0.0185	63.3	0.641	-45.5
500	0.451	-122.1	24.83	111.5	0.0223	61.5	0.558	-51.2
600	0.450	-133.9	21.25	105.6	0.0238	58.6	0.485	-55.6
700	0.449	-142.5	18.53	101.1	0.0280	55.9	0.428	-58.5
800	0.451	-150.6	16.36	97.0	0.0284	57.8	0.378	-60.4
900	0.449	-156.4	14.62	93.7	0.0321	55.5	0.340	-62.8
1000	0.449	-161.7	13.25	91.1	0.0347	57.7	0.308	-63.1
1100	0.453	-166.3	12.05	88.4	0.0360	55.5	0.279	-64.9
1200	0.455	-171.0	11.05	86.3	0.0364	58.0	0.256	-64.1
1300	0.457	-175.0	10.23	84.0	0.0399	56.7	0.236	-65.2
1400	0.460	-178.3	9.50	82.0	0.0413	58.5	0.220	-65.5
1500	0.460	178.5	8.86	80.2	0.0438	54.8	0.204	-66.2
1600	0.466	175.5	8.32	78.1	0.0437	55.1	0.190	-65.9
1700	0.466	172.7	7.84	76.5	0.0465	56.5	0.176	-65.8
1800	0.471	169.8	7.41	74.8	0.0481	55.4	0.165	-66.4
1900	0.472	167.4	7.02	73.2	0.0517	56.0	0.157	-66.9
2000	0.476	165.0	6.69	71.6	0.0540	54.4	0.149	-66.8
2100	0.480	162.7	6.35	69.9	0.0560	56.9	0.139	-67.3
2200	0.483	160.5	6.08	68.5	0.0573	55.2	0.134	-67.8
2300	0.487	158.7	5.81	66.9	0.0604	52.3	0.126	-67.7
2400	0.489	156.8	5.56	65.4	0.0617	53.6	0.117	-68.2
2500	0.493	154.9	5.35	63.8	0.0633	53.4	0.110	-68.8
2600	0.497	153.0	5.14	62.2	0.0659	51.6	0.107	-70.8
2700	0.504	151.6	4.96	60.9	0.0690	52.2	0.101	-72.8
2800	0.507	149.5	4.77	59.6	0.0711	52.9	0.099	-73.4
2900	0.511	148.0	4.59	58.1	0.0714	50.9	0.091	-76.1
3000	0.515	146.3	4.47	56.5	0.0717	49.4	0.085	-78.0

Package Dimensions

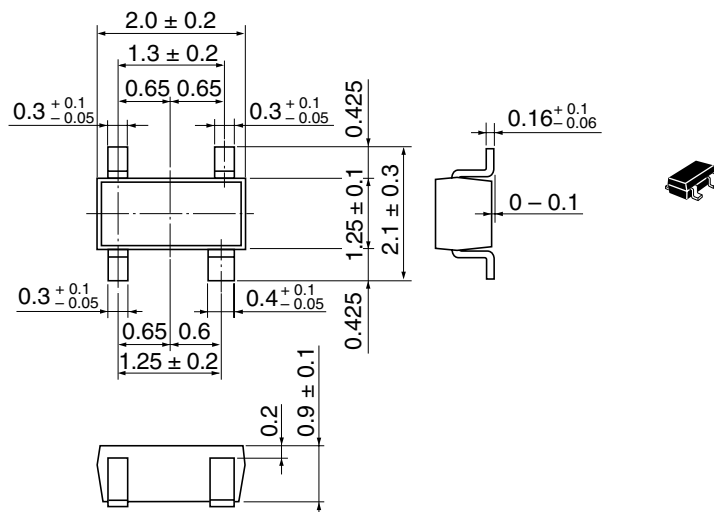
As of July, 2002
Unit: mm

Hitachi Code	CMPAK-4(T)
JEDEC	—
JEITA	Conforms
Mass (reference value)	0.006 g

Disclaimer

1. Hitachi neither warrants nor grants licenses of any rights of Hitachi's or any third party's patent, copyright, trademark, or other intellectual property rights for information contained in this document. Hitachi bears no responsibility for problems that may arise with third party's rights, including intellectual property rights, in connection with use of the information contained in this document.
2. Products and product specifications may be subject to change without notice. Confirm that you have received the latest product standards or specifications before final design, purchase or use.
3. Hitachi makes every attempt to ensure that its products are of high quality and reliability. However, contact Hitachi's sales office before using the product in an application that demands especially high quality and reliability or where its failure or malfunction may directly threaten human life or cause risk of bodily injury, such as aerospace, aeronautics, nuclear power, combustion control, transportation, traffic, safety equipment or medical equipment for life support.
4. Design your application so that the product is used within the ranges guaranteed by Hitachi particularly for maximum rating, operating supply voltage range, heat radiation characteristics, installation conditions and other characteristics. Hitachi bears no responsibility for failure or damage when used beyond the guaranteed ranges. Even within the guaranteed ranges, consider normally foreseeable failure rates or failure modes in semiconductor devices and employ systemic measures such as fail-safes, so that the equipment incorporating Hitachi product does not cause bodily injury, fire or other consequential damage due to operation of the Hitachi product.
5. This product is not designed to be radiation resistant.
6. No one is permitted to reproduce or duplicate, in any form, the whole or part of this document without written approval from Hitachi.
7. Contact Hitachi's sales office for any questions regarding this document or Hitachi semiconductor products.

Sales Offices**HITACHI****Hitachi, Ltd.**

Semiconductor & Integrated Circuits
 Nippon Bldg., 2-6-2, Ohte-machi, Chiyoda-ku, Tokyo 100-0004, Japan
 Tel: (03) 3270-2111 Fax: (03) 3270-5109

URL <http://www.hitachisemiconductor.com/>

For further information write to:

Hitachi Semiconductor
 (America) Inc.
 179 East Tasman Drive
 San Jose, CA 95134
 Tel: <1> (408) 433-1990
 Fax: <1> (408) 433-0223

Hitachi Europe Ltd.
 Electronic Components Group
 Whitebrook Park
 Lower Cookham Road
 Maidenhead
 Berkshire SL6 8YA, United Kingdom
 Tel: <44> (1628) 585000
 Fax: <44> (1628) 778322

Hitachi Europe GmbH
 Electronic Components Group
 Dornacher Str 3
 D-85622 Feldkirchen
 Postfach 201, D-85619 Feldkirchen
 Germany
 Tel: <49> (89) 9 9180-0
 Fax: <49> (89) 9 29 30 00

Hitachi Asia Ltd.
 Hitachi Tower
 16 Collyer Quay #20-00
 Singapore 049318
 Tel : <65>-6538-6533/6538-8577
 Fax : <65>-6538-6933/6538-3877
 URL : <http://semiconductor.hitachi.com.sg>

Hitachi Asia Ltd.
 (Taipei Branch Office)
 4/F, No. 167, Tun Hwa North Road
 Hung-Kuo Building
 Taipei (105), Taiwan
 Tel : <886>-(2)-2718-3666
 Fax : <886>-(2)-2718-8180
 Telex : 23222 HAS-TP
 URL : <http://semiconductor.hitachi.com.tw>

Hitachi Asia (Hong Kong) Ltd.
 Group III (Electronic Components)
 7/F., North Tower
 World Finance Centre,
 Harbour City, Canton Road
 Tsim Sha Tsui, Kowloon Hong Kong
 Tel : <852>-2735-9218
 Fax : <852>-2730-0281
 URL : <http://semiconductor.hitachi.com.hk>

Copyright © Hitachi, Ltd., 2002. All rights reserved. Printed in Japan.

Colophon 7.0



LittleDiode supplies new, hard to find or obsolete electronic components and semiconductors all over the world.

With over two million different components listed you are sure to find the part you need.

Feel free to visit us today at our online store:

LittleDiode.com

Looking forward to providing you with the best possible service.