

IMX 7 Series

7 Watt DC-DC Converters



Wide input voltage ranges up to 150 V DC
1 or 2 outputs up to 48 V DC
1500...2500 V DC I/O electric strength test



- Magnetic feedback for single output models
- Short circuit protection
- Industry standard 2" x 1" case with 10.5 mm profile

Selection chart

| Output 1 | | Output 2 | | Input voltage | Type | Options ^{1,2} |
|---------------------|------------------|---------------------|-------------------|-----------------|-------------------------------|------------------------|
| U_o nom [V DC] | I_o nom [A] | U_o nom [V DC] | I_o nom [mA] | U_i [V DC] | | |
| 3.3 | 1.5 | - | - | 8.4...36 | 20 IMX 7-03-9 | -8, M, C, L, Z |
| 3.3 | 1.5 | - | - | 16.8...75 | 40 IMX 7-03-9 ³ | -8, M, C, L, Z |
| 3.3 | 1.5 | - | - | 40...121 | 70 IMX 7-03-9 | -8, M |
| 3.3 | 1.5 | - | - | 60...150 | 110 IMX 7-03-9 | -8, M |
| 5.1 | 1.2 | - | - | 8.4...36 | 20 IMX 7-05-9 | -8, M, C, L, Z |
| 5.1 | 1.2 | - | - | 16.8...75 | 40 IMX 7-05-9 ³ | -8, M, C, L, Z |
| 5.1 | 1.2 | - | - | 40...121 | 70 IMX 7-05-9 | -8, M |
| 5.1 | 1.2 | - | - | 60...150 | 110 IMX 7-05-9 | -8, M |
| 12 | 0.5 | - | - | 8.4...36 | 20 IMX 7-12-9C | -8 |
| 12 | 0.6 | - | - | 16.8...75 | 40 IMX 7-12-9C ³ | -8 |
| 15 | 0.4 | - | - | 8.4...36 | 20 IMX 7-15-9C | -8 |
| 15 | 0.48 | - | - | 16.8...75 | 40 IMX 7-15-9C ³ | -8 |
| 24 | 0.26 | - | - | 8.4...36 | 20 IMX 7-24-9C | -8 |
| 24 | 0.3 | - | - | 16.8...75 | 40 IMX 7-24-9C ³ | -8 |
| 5 | 0.7 | 5 | 0.7 | 8.4...36 | 20 IMX 7-05-05-9 | -8, M, C, L, Z |
| 5 | 0.7 | 5 | 0.7 | 16.8...75 | 40 IMX 7-05-05-9 ³ | -8, M, C, L, Z |
| 5 | 0.7 | 5 | 0.7 | 40...121 | 70 IMX 7-05-05-9 | -8, M |
| 5 | 0.7 | 5 | 0.7 | 60...150 | 110 IMX 7-05-05-9 | -8, M |
| 12 | 0.3 | 12 | 0.3 | 8.4...36 | 20 IMX 7-12-12-9 | -8, M, C, L, Z |
| 12 | 0.3 | 12 | 0.3 | 16.8...75 | 40 IMX 7-12-12-9 ³ | -8, M, C, L, Z |
| 12 | 0.3 | 12 | 0.3 | 40...121 | 70 IMX 7-12-12-9 | -8, M |
| 12 | 0.3 | 12 | 0.3 | 60...150 | 110 IMX 7-12-12-9 | -8, M |
| 15 | 0.24 | 15 | 0.24 | 8.4...36 | 20 IMX 7-15-15-9 | -8, M, C, L, Z |
| 15 | 0.24 | 15 | 0.24 | 16.8...75 | 40 IMX 7-15-15-9 ³ | -8, M, C, L, Z |
| 15 | 0.24 | 15 | 0.24 | 40...121 | 70 IMX 7-15-15-9 | -8, M |
| 15 | 0.24 | 15 | 0.24 | 60...150 | 110 IMX 7-15-15-9 | -8, M |
| 24 | 0.15 | 24 | 0.15 | 8.4...36 | 20 IMX 7-24-24-9 | -8, M, C, L, Z |
| 24 | 0.15 | 24 | 0.15 | 16.8...75 | 40 IMX 7-24-24-9 ³ | -8, M, C, L, Z |
| 24 | 0.15 | 24 | 0.15 | 40...121 | 70 IMX 7-24-24-9 | -8, M |
| 24 | 0.15 | 24 | 0.15 | 60...150 | 110 IMX 7-24-24-9 | -8, M |

¹ For minimum order quantity and lead time contact Power-One.

² Option M, C, L and Z exclude each other.

³ Operation at lower input voltage possible: P_o approx. 80% of $P_{o, nom}$ at $U_{i, min} = 14.4$ V

Input

| | | |
|---------------------|-----------|----------------|
| Input voltage range | 20 IMX 7 | 8.4...36 V DC |
| | 40 IMX 7 | 16.8...75 V DC |
| | 70 IMX 7 | 40...121 V DC |
| | 110 IMX 7 | 60...150 V DC |

Output

| | | |
|---------------------------------|---|--|
| Output voltage setting accuracy | $U_{i\text{ nom}}$, 50% $I_{o\text{ nom}}$, single output models | $\pm 0.5\% U_{o\text{ nom}}$ |
| | $U_{i\text{ nom}}$, 50% $I_{o\text{ nom}}$, double outp., main/aux. outp. | $\pm 1\% / \pm 1.2\% U_{o\text{ nom}}$ |
| Minimum load | recommended for double output models | 10% $I_{o\text{ nom}}$ |
| Line/load regulation | $U_{i\text{ min}} \dots U_{i\text{ max}}$, 50% $I_{o\text{ nom}}$, single output models | $\pm 1\% U_{o\text{ nom}}$ |
| Line regulation | $U_{i\text{ nom}}$, 50% $I_{o\text{ nom}}$, double output models | $\pm 1\% U_{o\text{ nom}}$ |
| Load regulation | $U_{i\text{ nom}}$, 10...100% $I_{o\text{ nom}}$, double outp. models, main outp. | $\pm 3\% U_{o\text{ nom}}$ |
| | tracking output | $\pm 3\% U_{o\text{ nom}}$ |
| Output voltage switching noise | $U_{i\text{ nom}}$, 0...100% $I_{o\text{ nom}}$, peak-peak, total | max. 1.5% $U_{o\text{ nom}}$ |
| Efficiency | $U_{i\text{ nom}}$, $I_{o\text{ nom}}$ | up to 84% |

Control and protection

| | | |
|----------------------|--|-----------------------------------|
| Input protection | suppressor diode | |
| Overload protection | $U_{i\text{ min}} \dots U_{i\text{ max}}$, fully protected, hiccup mode | |
| No-load protection | | |
| Remote shut down | TTL-compatible inhibit input | disabled with $\geq 2.4\text{ V}$ |
| Trim input for U_o | | |

Safety and EMC

| | | |
|--------------------------------|-------------------------|--------------------------|
| Electric strength test voltage | I/O (20/40/70/110 IMX7) | 1500/1500/2000/2500 V DC |
| Electromagnetic interference | with external filter | class B |

Environmental

| | | |
|-------------------------------|---|--------------|
| Operating ambient temperature | $U_{i\text{ nom}}$, $I_{o\text{ nom}}$ | -25...71 °C |
| Storage temperature | non operational | -40...100 °C |
| Relative humidity | non condensing | 93% |
| MTBF | G_B 40 °C, MIL-HDBK-217F, N2 | 1'650'000 h |

Options

| | | |
|----------------------------|---------------------------------|----|
| Extended temperature range | -40...85 °C, ambient, operating | -8 |
| SMD version | with pins | M |
| SMD version | with adapter PCB | L |
| Open frame without case | | Z |
| C-pinout | | C |

Accessories

| | |
|----------------------------------|--|
| DIN and chassis mounting bracket | |
|----------------------------------|--|

IMX 7 Series

7 Watt DC-DC Converters

Mechanical data

Tolerances ± 0.3 mm (0.012") unless otherwise indicated.



IMX 7

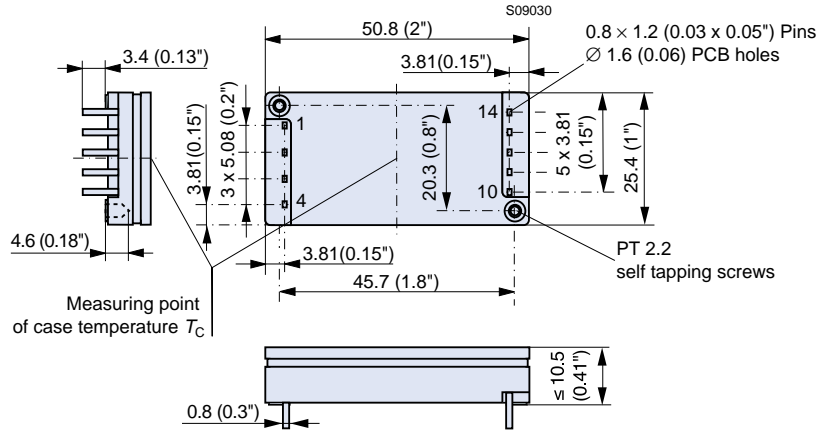

IMX 7 (option Z)

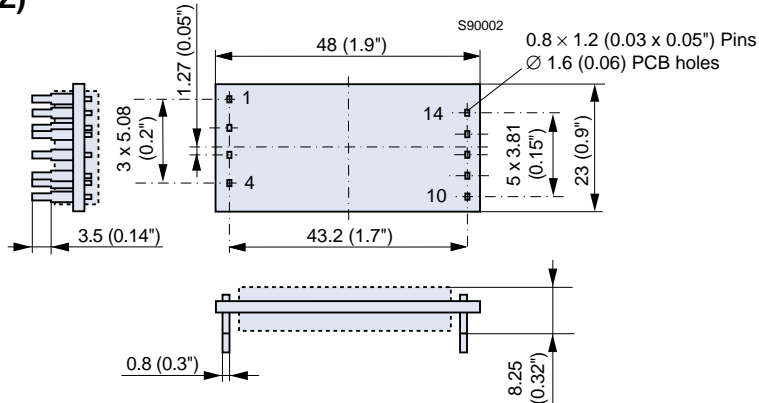

IMX 7 (option C)

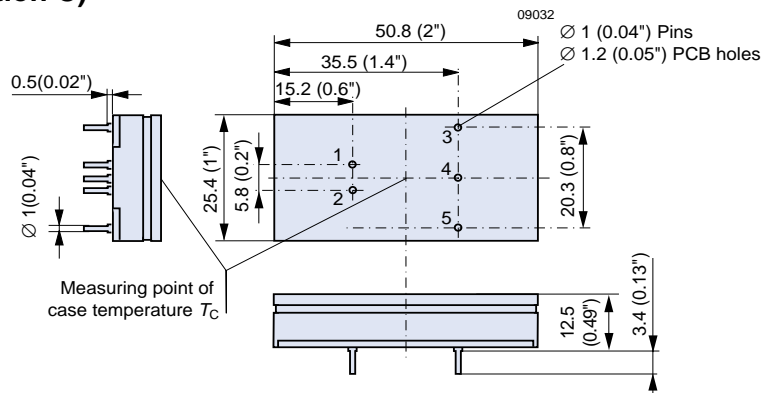

IMX 7 SMD version (option M)

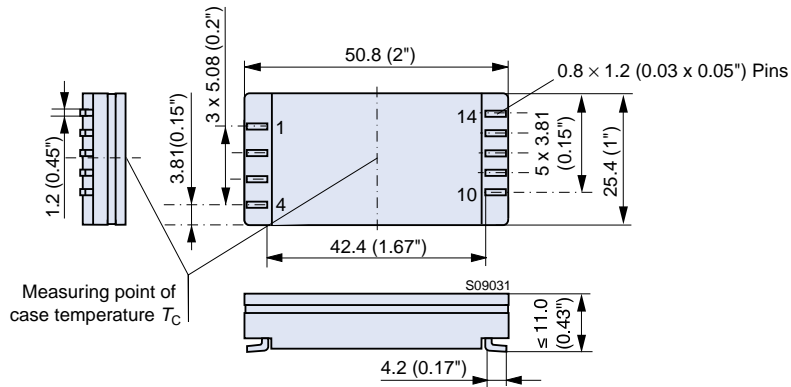

IMX 7 SMD version (option L)

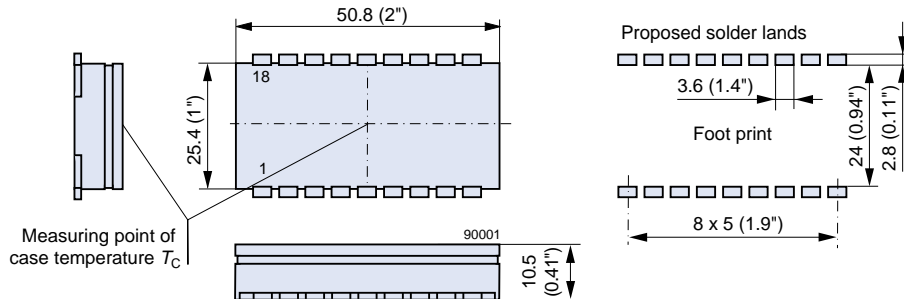

Pin allocation IMX 7, option M and Z

| Pin | Single output | Dual output |
|-----|---------------|-------------|
| 1 | Vi+ | Vi+ |
| 2 | Vi- | Vi- |
| 3 | i | i |
| 4 | n.c. | R (Trim) |
| 10 | Vo- | Vo1- |
| 11 | Vo+ | Vo1+ |
| 12 | Vo- | Vo2- |
| 13 | R | Vo2+ |
| 14 | n.c. | n.c. |

SMD version (option L)

| Pin | Single output | Dual output |
|-----|---------------|-------------|
| 1 | Vo | Vo1 |
| 2 | Go | Go |
| 3 | n.c. | Vo2 |
| 4 | n.c. | n.c. |
| 5 | n.c. | n.c. |
| 6 | n.c. | n.c. |
| 7 | n.c. | n.c. |
| 8 | n.c. | n.c. |
| 9 | n.c. | Trim |
| 10 | n.c. | n.c. |
| 11 | i | i |
| 12 | no pin | no pin |
| 13 | no pin | no pin |
| 14 | n.c. | n.c. |
| 15 | n.c. | n.c. |
| 16 | n.c. | n.c. |
| 17 | Vi- | Vi- |
| 18 | Vi+ | Vi+ |

C pinout (option C)

| Pin | Single output | Dual output |
|-----|---------------|-------------|
| 1 | Vi+ | Vi+ |
| 2 | Vi- | Vi- |
| 3 | Vo+ | Vo+ |
| 4 | no pin | Go |
| 5 | Vo- | Vo- |



LittleDiode supplies new, hard to find or obsolete electronic components and semiconductors all over the world.

With over two million different components listed you are sure to find the part you need.

Feel free to visit us today at our online store:

LittleDiode.com

Looking forward to providing you with the best possible service.