

# Emitter common (dual digital transistors)

## EMA3 / UMA3N / FMA3A

**●Features**

- 1) Two DTA143Ts in a EMT or UMT or SMT package.
- 2) Mounting cost and area can be cut in half.

**●Structure**

Epitaxial planar type PNP silicon transistor (Built-in resistor type.)

The following characteristics apply to both DTr1 and DTr2.

**●Equivalent circuit**

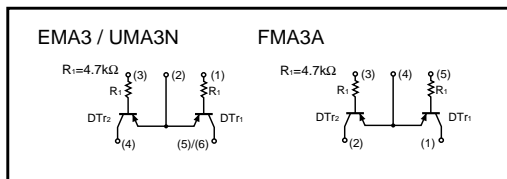

**●External dimensions (Units : mm)**

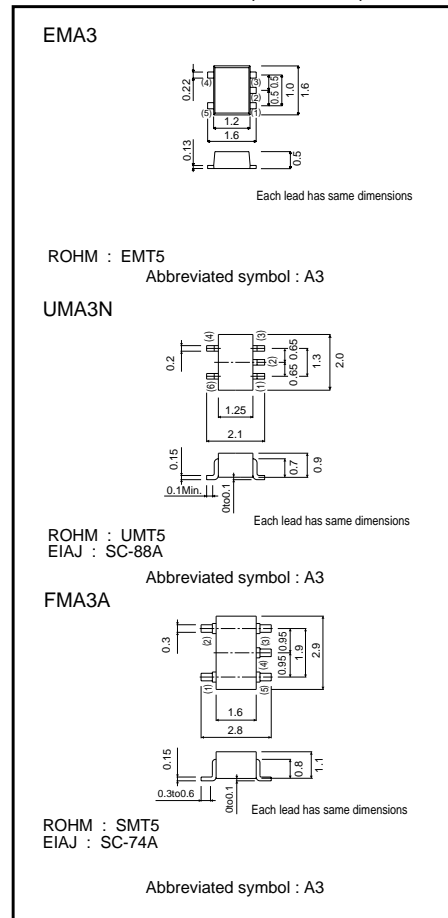

Transistors

●Absolute maximum ratings (Ta = 25°C)

Parameter	Symbol	Limits	Unit
Collector-base voltage	V <sub>CB0</sub>	-50	V
Collector-emitter voltage	V <sub>CE0</sub>	-50	V
Emitter-base voltage	V <sub>EB0</sub>	-5	V
Collector current	I <sub>c</sub>	-100	mA
Collector power dissipation	EMA3, UMA3N	150 (TOTAL)	mW *1
	FMA3A	300 (TOTAL)	
Junction temperature	T <sub>j</sub>	150	°C
Storage temperature	T <sub>stg</sub>	-55~+150	°C

\*1 120mW per element must not be exceeded.  
 \*2 200mW per element must not be exceeded.

●Electrical characteristics (Ta = 25°C)

Parameter	Symbol	Min.	Typ.	Max.	Unit	Conditions
Collector-base breakdown voltage	BV <sub>CB0</sub>	-50	-	-	V	I <sub>c</sub> =-50μA
Collector-emitter breakdown voltage	BV <sub>CE0</sub>	-50	-	-	V	I <sub>c</sub> =-1mA
Emitter-base breakdown voltage	BV <sub>EB0</sub>	-5	-	-	V	I <sub>E</sub> =-50μA
Collector cutoff current	I <sub>cBO</sub>	-	-	-0.5	μA	V <sub>CB</sub> =-50V
DC current transfer ratio	h <sub>FE</sub>	100	250	600	-	V <sub>CE</sub> /I <sub>c</sub> =-5V/-1mA
Emitter cutoff current	I <sub>EBO</sub>	-	-	-0.5	μA	V <sub>EB</sub> =-4V
Collector-emitter saturation voltage	V <sub>CE(sat)</sub>	-	-	-0.3	V	I <sub>c</sub> /I <sub>B</sub> =-5mA/-0.25mA
Transition frequency	f <sub>T</sub>	-	250	-	MHz	V <sub>CE</sub> =-10mA, I <sub>E</sub> =5mA, f=100MHz *
Input resistance	R <sub>i</sub>	3.29	4.7	6.11	kΩ	-

\* Transition frequency of the device

●Packaging specifications

Type	Package	Taping		
	Code	T2R	TR	T148
	Basic ordering unit (pieces)	8000	3000	3000
EMA3	○	—	—	—
UMA3N	—	○	—	—
FMA3A	—	—	—	○

●Electrical characteristic curves

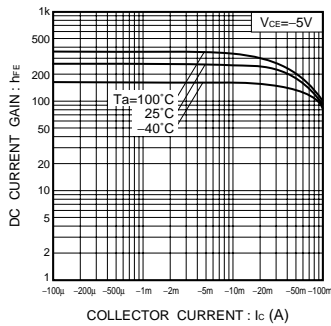

Fig.1 DC current gain vs. collector current

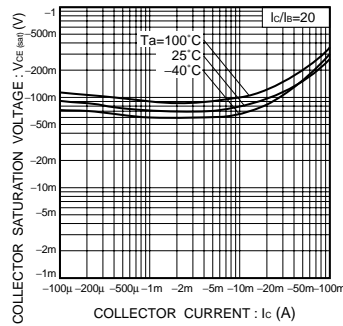

Fig.2 Collector-emitter saturation voltage vs. collector current



LittleDiode supplies new, hard to find or obsolete electronic components and semiconductors all over the world.

With over two million different components listed you are sure to find the part you need.

Feel free to visit us today at our online store:

[LittleDiode.com](http://LittleDiode.com)

Looking forward to providing you with the best possible service.