

Digital transistor (Common Emitter Dual Transistors)

UMA9N / FMA9N

●Features

- 1) Two DTA114E chips in UMT and SMT packages.
- 2) Mounting cost and area can be cut in half.

●Structure

Epitaxial planar type
PNP silicon transistor
(Built-in resistor type)

The following characteristics apply to both DT_{r1} and DT_{r2}.

●External dimensions (Units : mm)

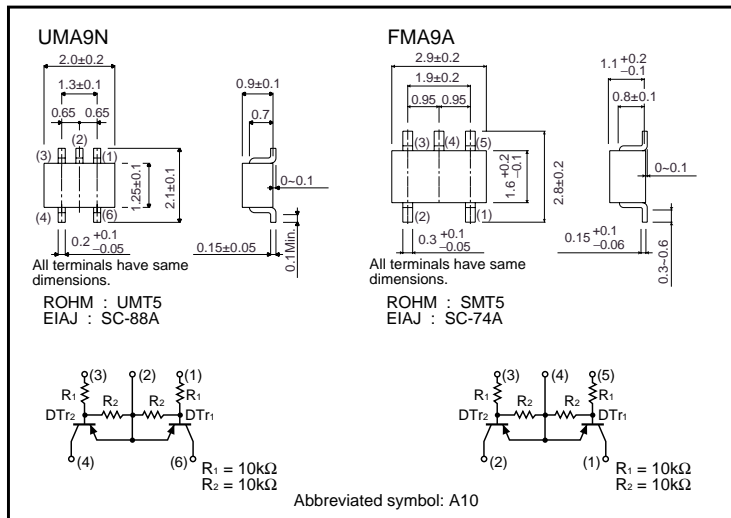

●Absolute maximum ratings (Ta=25°C)

| Parameter | Symbol | Limits | Unit |
|----------------------|-----------------------|-------------|-------|
| Supply voltage | V _{CC} | -50 | V |
| Input voltage | V _{IN} | -40 | V |
| | | 10 | |
| Output current | I _O | -50 | mA |
| | I _{C (MAX.)} | -100 | |
| Power dissipation | UMA9N | 150 (TOTAL) | mW *1 |
| | FMA9A | 300 (TOTAL) | mW *2 |
| Junction temperature | T _J | 150 | °C |
| Storage temperature | T _{stg} | -50~+150 | °C |

*1 120mW per element must not be exceeded.
*2 200mW per element must not be exceeded.

Transistors

●Electrical characteristics (Ta=25°C)

| Parameter | Symbol | Min. | Typ. | Max. | Unit | Conditions |
|----------------------|--------------|------|------|-------|-----------|-------------------------------------|
| Input voltage | $V_{I(off)}$ | - | - | -0.5 | V | $V_{CC}=-5V, I_o=-100\mu A$ |
| | $V_{I(on)}$ | -3.0 | - | - | | $V_o=-0.3V, I_o=-10mA$ |
| Output voltage | $V_{O(on)}$ | - | -0.1 | -0.3 | V | $I_o/I_i=-10mA / -0.5mA$ |
| Input current | I_i | - | - | -0.88 | mA | $V_i=-5V$ |
| Output current | $I_o(off)$ | - | - | -0.5 | μA | $V_{CC}=-50V, V_i=0V$ |
| DC current gain | G_i | 30 | - | - | - | $I_o=-5mA, V_o=-5V$ |
| Transition frequency | f_T | - | 250 | - | MHz | $V_{CE}=-10mA, I_E=5mA, f=100MHz$ * |
| Input resistance | R_1 | 7 | 10 | 13 | $k\Omega$ | - |
| Resistance ratio | R_2/R_1 | 0.8 | 1 | 1.2 | - | - |

* Transition frequency of the device

●Packaging specifications

| Part No. | Packaging type | Taping | |
|----------|------------------------------|--------|------|
| | Code | TR | T148 |
| | Basic ordering unit (pieces) | 3000 | 3000 |
| UMA9N | | ○ | - |
| FMA9A | | - | ○ |

●Electrical characteristic curves

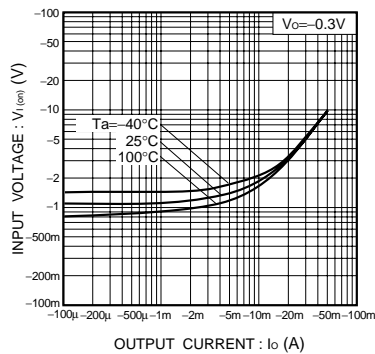

Fig.1 Input voltage vs. output current (ON characteristics)

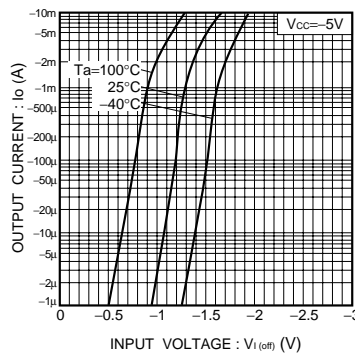

Fig.2 Output current vs. input voltage (OFF characteristics)

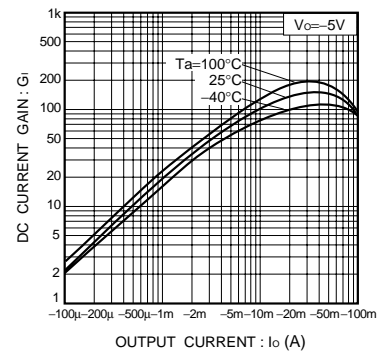

Fig.3 DC current gain vs. output current

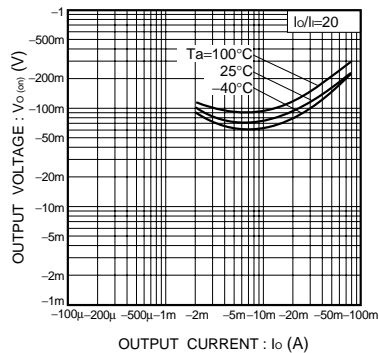

Fig.4 Output voltage vs. output current



LittleDiode supplies new, hard to find or obsolete electronic components and semiconductors all over the world.

With over two million different components listed you are sure to find the part you need.

Feel free to visit us today at our online store:

LittleDiode.com

Looking forward to providing you with the best possible service.