

General purpose (dual digital transistors)

EMB3 / UMB3N / IMB3A

●Features

- 1) Two DTA143T chips in a EMT or UMT or SMT package.
- 2) Mounting possible with EMT3 or UMT3 or SMT3 automatic mounting machines.
- 3) Transistor elements are independent, eliminating interference.

●Structure

Dual PNP digital transistor
(each with single built in resistor)

The following characteristics apply to both DT_{r1} and DT_{r2}.

●Equivalent circuit

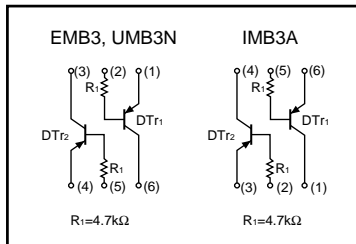

●External dimensions (Units : mm)

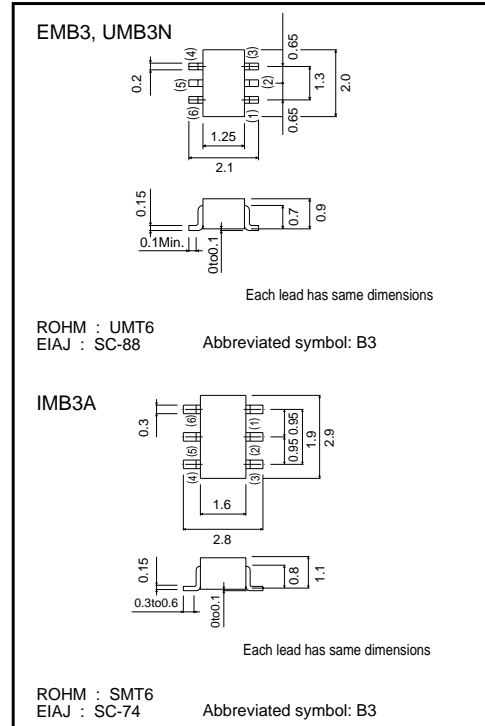

●Packaging specifications

Type	Package	Taping		
	Code	T2R	TN	T110
	Basic ordering unit (pieces)	8000	3000	3000
EMB3		○	-	-
UMB3N		-	○	-
IMB3N		-	-	○

●Absolute maximum ratings (Ta = 25°C)

Parameter	Symbol	Limits	Unit
Collector-base voltage	V _{CBO}	-50	V
Collector-emitter voltage	V _{CEO}	-50	V
Emitter-base voltage	V _{EBO}	-5	V
Collector current	I _c	-100	mA
Collector power dissipation	EMB3, UMB3N	150 (TOTAL)	mW *1
	IMB3A	300 (TOTAL)	mW *2
Junction temperature	T _J	150	°C
Storage temperature	T _{stg}	-55~+150	°C

*1 120mW per element must not be exceeded.
*2 200mW per element must not be exceeded.

Transistors

●Electrical characteristics (Ta = 25°C)

Parameter	Symbol	Min.	Typ.	Max.	Unit	Conditions
Collector-base breakdown voltage	BV_{CBO}	-50	-	-	V	$I_C = -50\mu A$
Collector-emitter breakdown voltage	BV_{CEO}	-50	-	-	V	$I_C = -1mA$
Emitter-base breakdown voltage	BV_{EBO}	-5	-	-	V	$I_E = -50\mu A$
Collector cutoff current	I_{CBO}	-	-	-0.5	μA	$V_{CB} = -50V$
Emitter cutoff current	I_{EBO}	-	-	-0.5	μA	$V_{EB} = -4V$
Collector-emitter saturation voltage	$V_{CE(sat)}$	-	-	-0.3	V	$I_C/I_B = -5mA/-2.5mA$
DC current transfer ratio	h_{FE}	100	250	600	-	$V_{CE} = -5V, I_C = -1mA$
Transition frequency	f_T	-	250	-	MHz	$V_{CE} = 10mA, I_E = -5mA, f = 100MHz$ *
Input resistance	R_i	3.29	4.7	6.11	$k\Omega$	-

* Transition frequency of the device

●Electrical characteristic curves

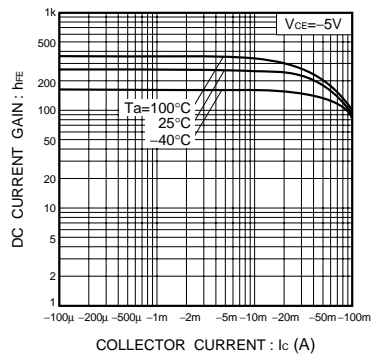

Fig.1 DC current gain vs. collector current

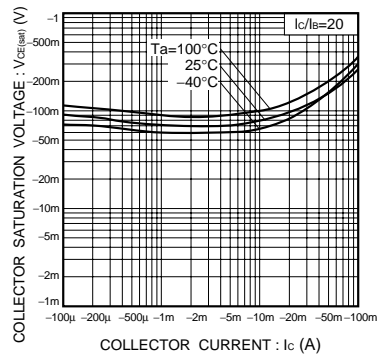

Fig.2 Collector-emitter saturation voltage vs. collector current



LittleDiode supplies new, hard to find or obsolete electronic components and semiconductors all over the world.

With over two million different components listed you are sure to find the part you need.

Feel free to visit us today at our online store:

LittleDiode.com

Looking forward to providing you with the best possible service.