

# Medium power transistor (30V, 2A)

## 2SC5916

### ●Features

- 1) High speed switching. ( $T_f$  : Typ. : 20ns at  $I_c = 2A$ )
- 2) Low saturation voltage, typically  
(Typ. : 200mV at  $I_c = 1.0A, I_b = 0.1A$ )
- 3) Strong discharge power for inductive load and capacitance load.
- 4) Complements the 2SA2113

### ●Applications

Low frequency amplifier  
High speed switching

### ●Structure

NPN Silicon epitaxial planar transistor

### ●Packaging specifications

Type	Package	Taping
	Code	TL
	Basic ordering unit (pieces)	3000
2SC5916		○

### ●Absolute maximum ratings ( $T_a = 25^\circ C$ )

Parameter	Symbol	Limits	Unit
Collector-base voltage	$V_{CB0}$	30	V
Collector-emitter voltage	$V_{CE0}$	30	V
Emitter-base voltage	$V_{EB0}$	6	V
Collector current	$I_c$	2	A
	$I_{cP}$	4	A *1
Power dissipation	$P_c$	500	mW *2
Junction temperature	$T_j$	150	$^\circ C$
Range of storage temperature	$T_{stg}$	-55~+150	$^\circ C$

\*1  $P_w = 10ms$

\*2 Each terminal mounted on a recommended land.

### ●External dimensions (Units : mm)

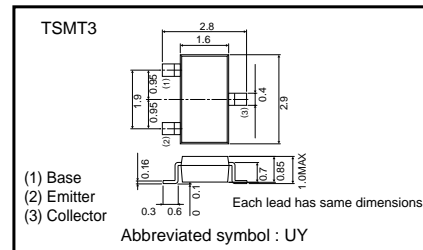

Transistor

●Electrical characteristics (Ta=25°C)

Parameter	Symbol	Min.	Typ.	Max.	Unit	Conditions
Collector-base breakdown voltage	$BV_{CEO}$	30	-	-	V	$I_C=100\mu A$
Collector-emitter breakdown voltage	$BV_{CBO}$	30	-	-	V	$I_C=1mA$
Emitter-base breakdown voltage	$BV_{EBO}$	6	-	-	V	$I_E=100\mu A$
Collector cut-off current	$I_{CBO}$	-	-	1.0	$\mu A$	$V_{CB}=20V$
Emitter cut-off current	$I_{EBO}$	-	-	1.0	$\mu A$	$V_{EB}=4V$
Collector-emitter saturation voltage	$V_{CE(sat)}$	-	200	400	mV	$I_C=1.0A, I_B=0.1A$
DC current gain	$h_{FE}$	120	-	390	-	$V_{CE}=2V, I_C=100mA$
Transition frequency	$f_T$	-	250	-	MHz	$V_{CE}=10V, I_E=-100mA, f=10MHz$
Collector output capacitance	$C_{ob}$	-	15	-	pF	$V_{CB}=10V, I_E=0, f=1MHz$
Turn-on time	$T_{on}$	-	25	-	ns	$I_C=2A$
Storage time	$T_{stg}$	-	100	-	ns	$I_{B1}=200mA$
Fall time	$T_f$	-	20	-	ns	$I_{B2}=-200mA$
						$V_{CC}=-25V$

● $h_{FE}$  RANK

Q	R
120-270	180-390

●Electrical characteristic curves

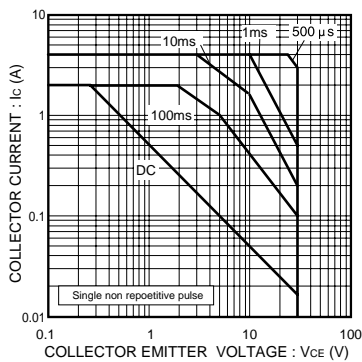

Fig.1 Safe operating area

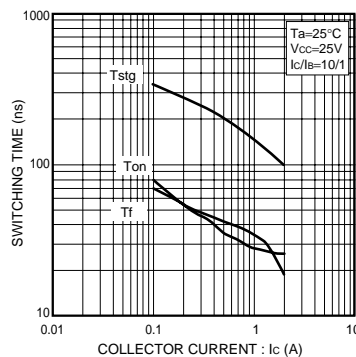

Fig.2 Switching Time

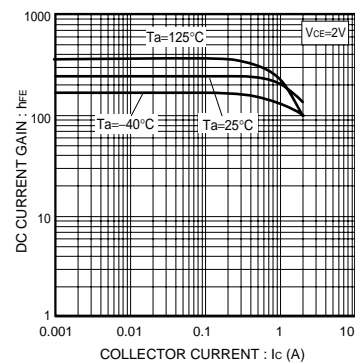

Fig.3 DC current gain vs. collector current

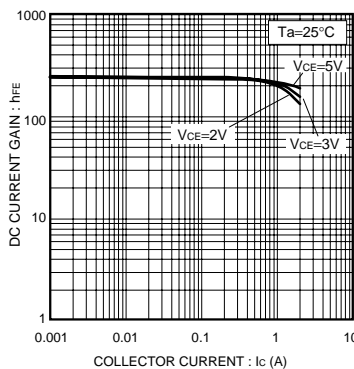

Fig.4 DC current gain vs. collector current

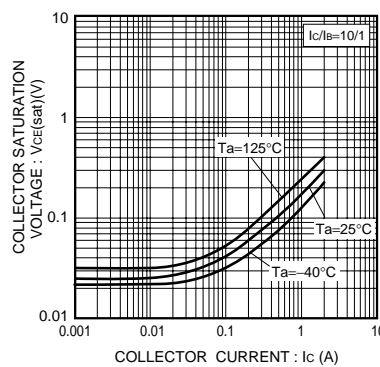

Fig.5 Collector-emitter saturation voltage vs. collector current

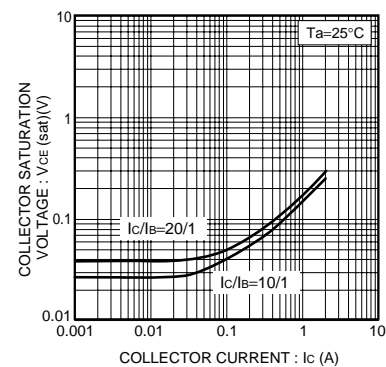

Fig.6 Collector-emitter saturation voltage vs. collector current

Transistor

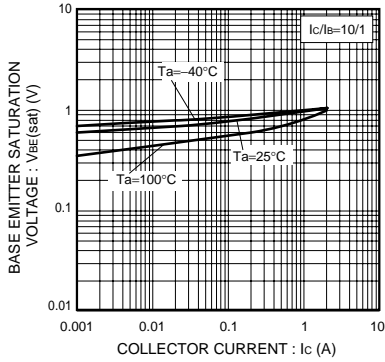

Fig.7 Base-emitter saturation voltage vs. collector current

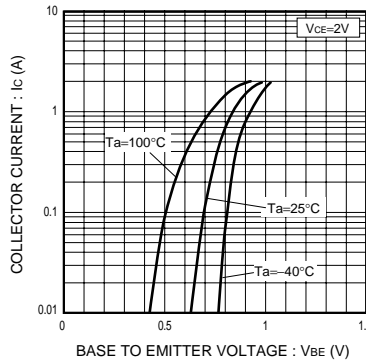

Fig.8 Ground emitter propagation characteristics

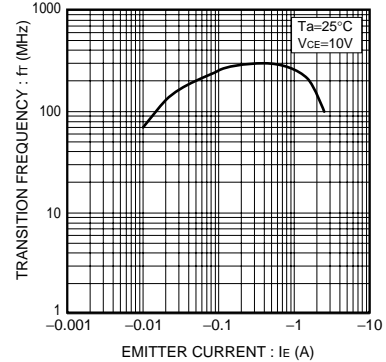

Fig.9 Transition frequency

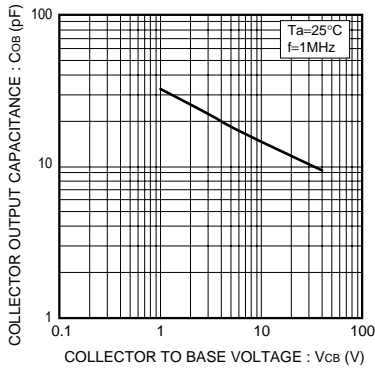
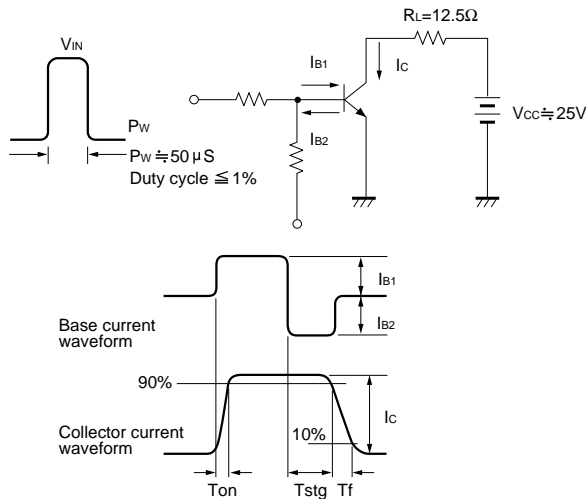

Fig.10 Collector output capacitance

●Switching characteristics measurement circuits





LittleDiode supplies new, hard to find or obsolete electronic components and semiconductors all over the world.

With over two million different components listed you are sure to find the part you need.

Feel free to visit us today at our online store:

[LittleDiode.com](http://LittleDiode.com)

Looking forward to providing you with the best possible service.