

MECHANICAL DATA

Dimensions in mm (inches)

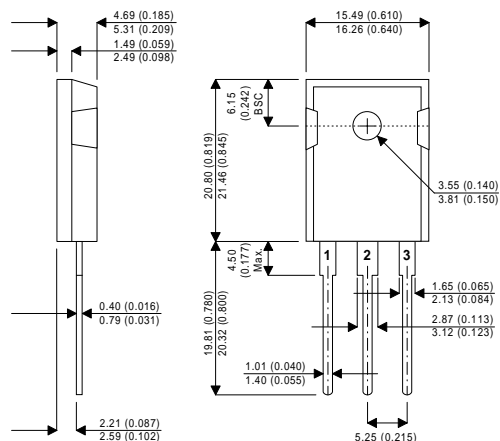

TO-247

Pin 1 – Base Pad 2 – Collector Pad 3 – Emitter

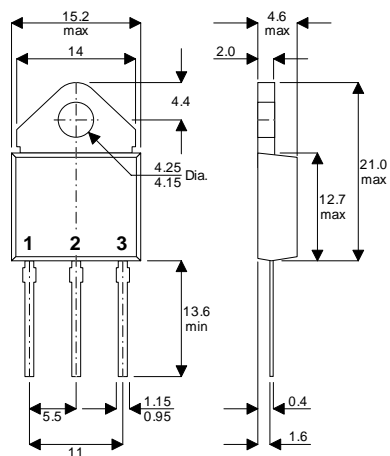

SOT93

Pin 1 – Base Pad 2 – Collector Pad 3 – Emitter

**ADVANCED
DISTRIBUTED BASE DESIGN
HIGH VOLTAGE
HIGH SPEED NPN
SILICON POWER TRANSISTOR**

- SEMEFAB DESIGNED AND DIFFUSED DIE
- HIGH VOLTAGE
- FAST SWITCHING
- HIGH ENERGY RATING
- EFFICIENT POWER SWITCHING
- MILITARY AND HI-REL VERSIONS AVAILABLE IN METAL AND CERAMIC SURFACE MOUNT PACKAGES

FEATURES

- Multi-base for efficient energy distribution across the chip resulting in significantly improved switching and energy ratings across full temperature range.
- Ion implant and high accuracy masking for tight control of characteristics from batch to batch.
- Triple Guard Rings for improved control of high voltages.

ABSOLUTE MAXIMUM RATINGS ($T_{case} = 25^{\circ}C$ unless otherwise stated)

V_{CBO}	Collector – Base Voltage	1000V
V_{CEO}	Collector – Emitter Voltage ($I_B = 0$)	500V
V_{EBO}	Emitter – Base Voltage ($I_C = 0$)	10V
I_C	Continuous Collector Current	15A
$I_{C(PK)}$	Peak Collector Current	30A
I_B	Base Current	5A
P_{tot}	Total Dissipation at $T_{case} = 25^{\circ}C$	125W
T_{stg}	Operating and Storage Temperature Range	-55 to +175°C

ELECTRICAL CHARACTERISTICS ($T_{\text{case}} = 25^{\circ}\text{C}$ unless otherwise stated)

Parameter	Test Conditions	Min.	Typ.	Max.	Unit	
ELECTRICAL CHARACTERISTICS						
$V_{\text{CEO(sus)}}$	Collector – Emitter Sustaining Voltage	$I_{\text{C}} = 100\text{mA}$	500		V	
$V_{\text{(BR)CBO}}$	Collector – Base Breakdown Voltage	$I_{\text{C}} = 1\text{mA}$	1000			
$V_{\text{(BR)EBO}}$	Emitter – Base Breakdown Voltage	$I_{\text{E}} = 1\text{mA}$	10			
I_{CBO}	Collector – Base Cut-Off Current	$V_{\text{CB}} = 1000\text{V}$		10	μA	
			$T_{\text{C}} = 125^{\circ}\text{C}$	100		
I_{CEO}	Collector – Emitter Cut-Off Current	$I_{\text{B}} = 0$	$V_{\text{CE}} = 500\text{V}$	100	μA	
I_{EBO}	Emitter Cut-Off Current	$V_{\text{EB}} = 5\text{V}$	$I_{\text{C}} = 0$		10	
				$T_{\text{C}} = 125^{\circ}\text{C}$	100	
h_{FE}^*	DC Current Gain	$I_{\text{C}} = 0.5\text{A}$	$V_{\text{CE}} = 4\text{V}$	15	50	—
		$I_{\text{C}} = 5\text{A}$	$V_{\text{CE}} = 4\text{V}$	10	20	
		$I_{\text{C}} = 10\text{A}$	$V_{\text{CE}} = 4\text{V}$	5	12	
			$T_{\text{C}} = 125^{\circ}\text{C}$	4	10	
$V_{\text{CE(sat)}}^*$	Collector – Emitter Saturation Voltage	$I_{\text{C}} = 0.5\text{A}$	$I_{\text{B}} = 0.1\text{A}$	0.05	0.1	V
		$I_{\text{C}} = 5\text{A}$	$I_{\text{B}} = 1\text{A}$	0.2	0.4	
		$I_{\text{C}} = 10\text{A}$	$I_{\text{B}} = 2\text{A}$	0.3	1.2	
$V_{\text{BE(sat)}}^*$	Base – Emitter Saturation Voltage	$I_{\text{C}} = 5\text{A}$	$I_{\text{B}} = 1\text{A}$	0.9	1.1	V
		$I_{\text{C}} = 10\text{A}$	$I_{\text{B}} = 2\text{A}$	1.0	1.3	
$V_{\text{BE(on)}}$	Base – Emitter On Voltage	$I_{\text{C}} = 3\text{A}$	$V_{\text{CE}} = 4\text{V}$	0.8	1.0	V
DYNAMIC CHARACTERISTICS						
f_{t}	Transition Frequency	$I_{\text{C}} = 0.2\text{A}$	$V_{\text{CE}} = 4\text{V}$	20		MHz
C_{ob}	Output Capacitance	$V_{\text{CB}} = 20\text{V}$	$f = 1\text{MHz}$	45		pF

* Pulse test $t_{\text{p}} = 300\mu\text{s}$, $\delta < 2\%$



LittleDiode supplies new, hard to find or obsolete electronic components and semiconductors all over the world.

With over two million different components listed you are sure to find the part you need.

Feel free to visit us today at our online store:

LittleDiode.com

Looking forward to providing you with the best possible service.