

Low voltage fast-switching NPN power transistor

Features

- Very low collector-emitter saturation voltage
- High current gain characteristic
- Fast switching speed
- Miniature SOT-23 plastic package for surface mounting circuits

Applications

- LED
- Motherboard & hard disk drive
- Mobile equipment
- DC-DC converter
- Voltage regulation

Description

The device is a NPN transistor manufactured using new "PB-HCD" (power bipolar high current density) technology. The resulting transistor shows exceptional high gain performances coupled with very low saturation voltage.

The complementary PNP is the 2STR2230.

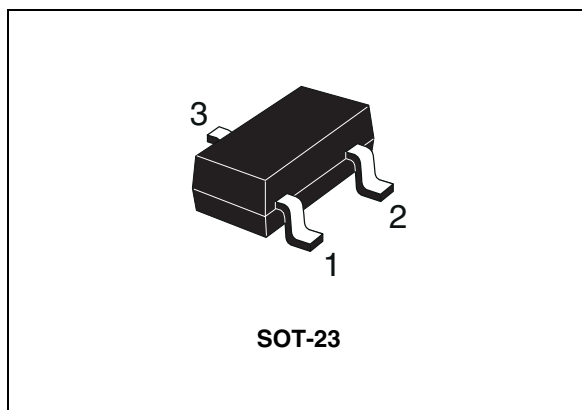

Figure 1. Internal schematic diagram

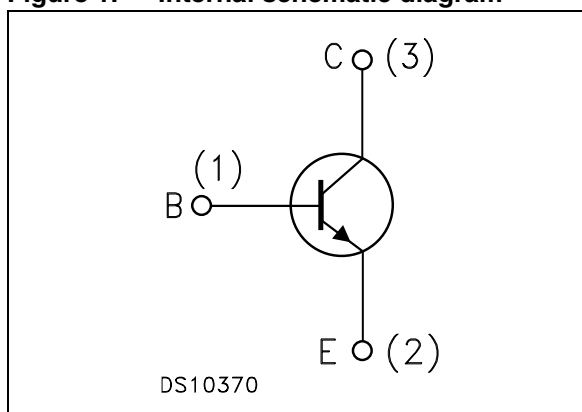

Table 1. Device summary

Order code ⁽¹⁾	Marking	Package	Packing
2STR1230	130	SOT-23	Tape and reel
2STR1230G	130G	SOT-23	Tape and reel

1. The letter "G" in the order code suffix identifies the product as ECOPACK@2 grade. Please see [Section 3](#) for details.

1 Electrical ratings

Table 2. Absolute maximum ratings

Symbol	Parameter	Value	Unit
V_{CES}	Collector-emitter voltage ($V_{BE} = 0$)	30	V
V_{CEO}	Collector-emitter voltage ($I_B = 0$)	30	V
V_{EBO}	Emitter-base voltage ($I_C = 0$)	5	V
I_C	Collector current	1.5	A
I_{CM}	Collector peak current ($t_P < 5$ ms)	3	A
P_{tot}	Total dissipation at $T_{amb} = 25$ °C	0.5	W
T_{stg}	Storage temperature	-65 to 150	°C
T_J	Max. operating junction temperature	150	°C

Table 3. Thermal data

Symbol	Parameter	Value	Unit
$R_{thJA}^{(1)}$	Thermal resistance junction-ambient max	250	°C/W

1. Device mounted on PCB area of 1 cm².

2 Electrical characteristics

$T_{\text{case}} = 25\text{ °C}$ unless otherwise specified

Table 4. Electrical characteristics

Symbol	Parameter	Test conditions	Min.	Typ.	Max.	Unit
I_{CBO}	Collector cut-off current ($I_{\text{E}} = 0$)	$V_{\text{CB}} = 30\text{ V}$			0.1	μA
I_{EBO}	Emitter cut-off current ($I_{\text{C}} = 0$)	$V_{\text{EB}} = 4\text{ V}$			0.1	μA
$V_{(\text{BR})\text{CBO}}$	Collector-base breakdown voltage ($I_{\text{E}} = 0$)	$I_{\text{C}} = 100\ \mu\text{A}$	30			V
$V_{(\text{BR})\text{CEO}}^{(1)}$	Collector-emitter breakdown voltage ($I_{\text{B}} = 0$)	$I_{\text{C}} = 10\text{ mA}$	30			V
$V_{(\text{BR})\text{EBO}}$	Emitter-base breakdown voltage ($I_{\text{C}} = 0$)	$I_{\text{E}} = 100\ \mu\text{A}$	5			V
$V_{\text{CE}(\text{sat})}^{(1)}$	Collector-emitter saturation voltage	$I_{\text{C}} = 0.1\text{ A}$ $I_{\text{B}} = 1\text{ mA}$ $I_{\text{C}} = 1\text{ A}$ $I_{\text{B}} = 100\text{ mA}$ $I_{\text{C}} = 2\text{ A}$ $I_{\text{B}} = 200\text{ mA}$		0.2 0.4	0.15 0.5 0.85	V V V
$V_{\text{BE}(\text{sat})}^{(1)}$	Base-emitter saturation voltage	$I_{\text{C}} = 1\text{ A}$ $I_{\text{B}} = 100\text{ mA}$			1.25	V
$h_{\text{FE}}^{(1)}$	DC current gain	$I_{\text{C}} = 50\text{ mA}$ $V_{\text{CE}} = 2\text{ V}$ $I_{\text{C}} = 0.5\text{ A}$ $V_{\text{CE}} = 2\text{ V}$ $I_{\text{C}} = 1\text{ A}$ $V_{\text{CE}} = 2\text{ V}$ $I_{\text{C}} = 2\text{ A}$ $V_{\text{CE}} = 2\text{ V}$	210 180 130 80	330	560	
C_{CBO}	Collector-base capacitance ($I_{\text{E}} = 0$)	$V_{\text{CB}} = 10\text{ V}$, $f = 1\text{ MHz}$		5		pF
t_{on} t_{off}	Resistive load Turn-on time Turn-off time	$I_{\text{C}} = 1.5\text{ A}$ $V_{\text{CC}} = 10\text{ V}$ $I_{\text{B1}} = - I_{\text{B2}} = 150\text{ mA}$		70 380		ns ns

1. Pulse test: pulse duration $\leq 300\ \mu\text{s}$, duty cycle $\leq 2\%$

2.1 Electrical characteristics (curves)

Figure 2. DC current gain

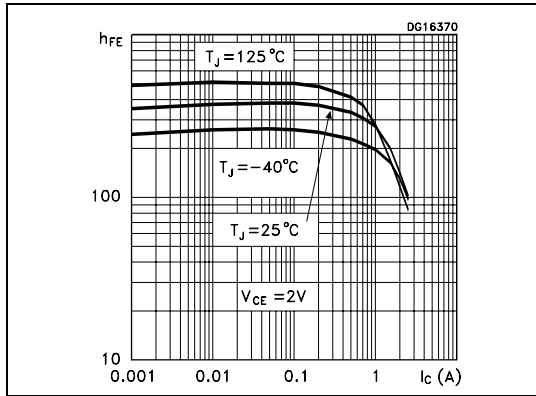

Figure 3. Collector-emitter saturation voltage

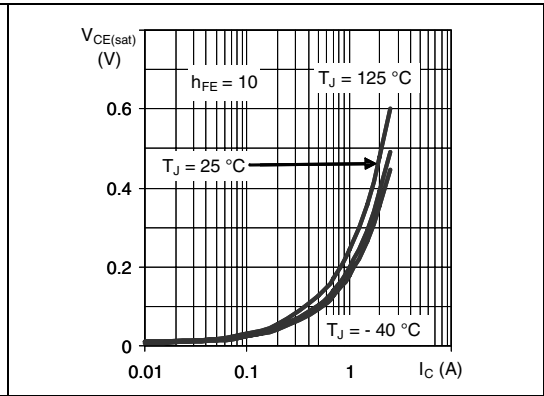

Figure 4. Base-emitter saturation voltage

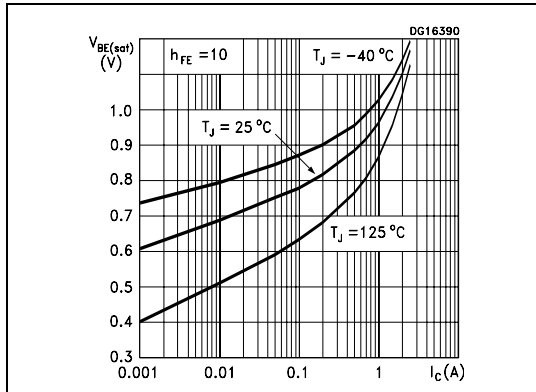

Figure 5. Resistive load switching on

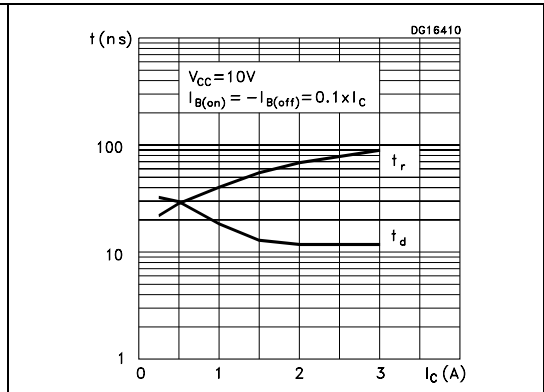

Figure 6. Resistive load switching off

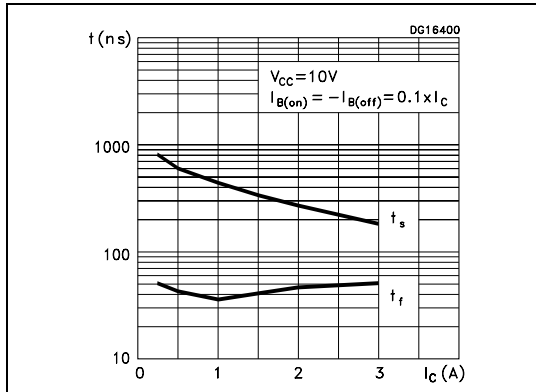
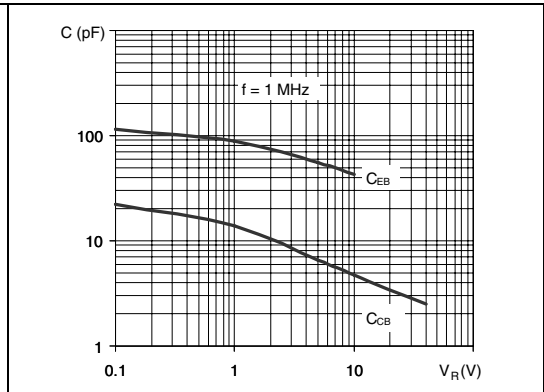
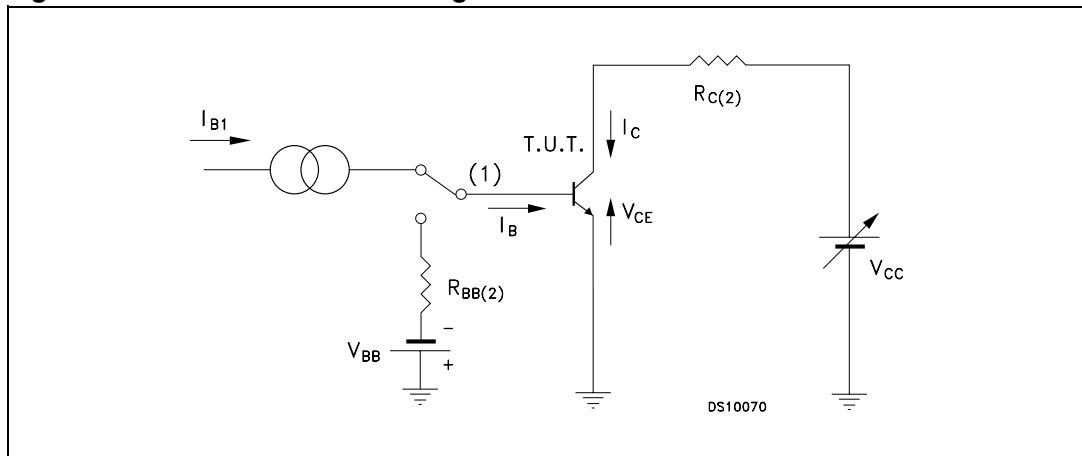

Figure 7. Capacitance



2.2 Test circuits

Figure 8. Resistive load switching test circuit



1. Fast electronic switch
2. Non-inductive resistor

3 Package mechanical data

In order to meet environmental requirements, ST offers these devices in different grades of ECOPACK[®] packages, depending on their level of environmental compliance. ECOPACK[®] specifications, grade definitions and product status are available at: www.st.com. ECOPACK[®] is an ST trademark.

SOT-23 mechanical data

DIM.	mm.		
	min.	typ	max.
A	0.89		1.4
A1	0		0.1
B	0.3		0.51
C	0.085		0.18
D	2.75		3.04
e	0.85		1.05
e1	1.7		2.1
E	1.2		1.6
H	2.1		2.75
L		0.6	
S	0.35		0.65

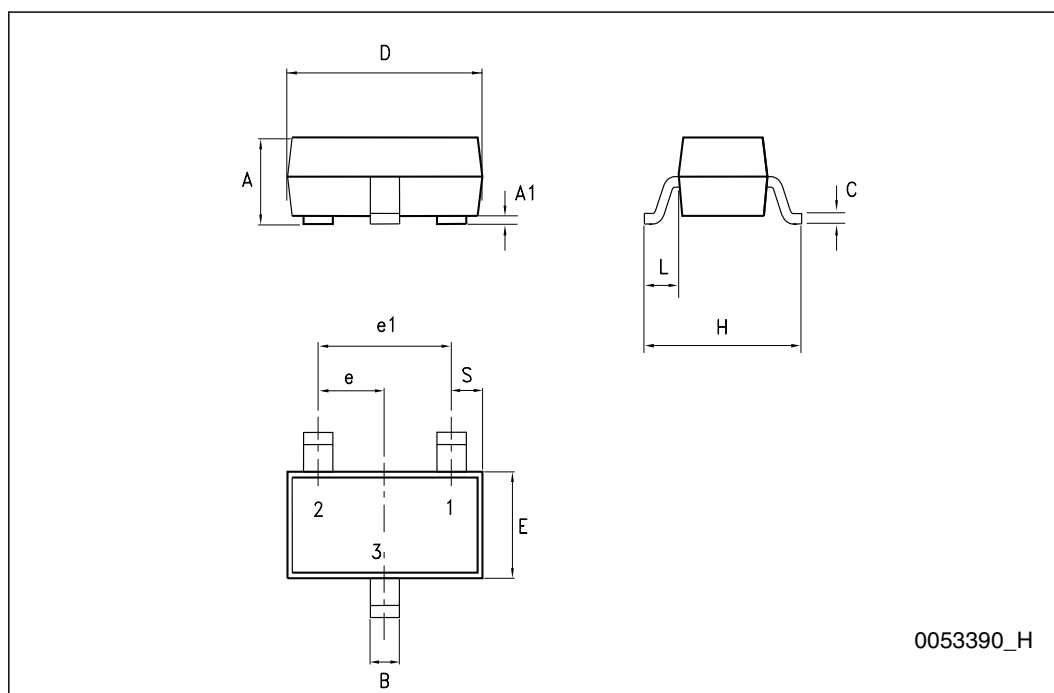

4 Revision history

Table 5. Document revision history

Date	Revision	Changes
18-Jul-2006	1	Initial release
24-Oct-2006	2	New graphics
09-Oct-2009	3	Updated: <i>Figure 3</i> , <i>Figure 7</i> and package mechanical data.

Please Read Carefully:

Information in this document is provided solely in connection with ST products. STMicroelectronics NV and its subsidiaries ("ST") reserve the right to make changes, corrections, modifications or improvements, to this document, and the products and services described herein at any time, without notice.

All ST products are sold pursuant to ST's terms and conditions of sale.

Purchasers are solely responsible for the choice, selection and use of the ST products and services described herein, and ST assumes no liability whatsoever relating to the choice, selection or use of the ST products and services described herein.

No license, express or implied, by estoppel or otherwise, to any intellectual property rights is granted under this document. If any part of this document refers to any third party products or services it shall not be deemed a license grant by ST for the use of such third party products or services, or any intellectual property contained therein or considered as a warranty covering the use in any manner whatsoever of such third party products or services or any intellectual property contained therein.

UNLESS OTHERWISE SET FORTH IN ST'S TERMS AND CONDITIONS OF SALE ST DISCLAIMS ANY EXPRESS OR IMPLIED WARRANTY WITH RESPECT TO THE USE AND/OR SALE OF ST PRODUCTS INCLUDING WITHOUT LIMITATION IMPLIED WARRANTIES OF MERCHANTABILITY, FITNESS FOR A PARTICULAR PURPOSE (AND THEIR EQUIVALENTS UNDER THE LAWS OF ANY JURISDICTION), OR INFRINGEMENT OF ANY PATENT, COPYRIGHT OR OTHER INTELLECTUAL PROPERTY RIGHT.

UNLESS EXPRESSLY APPROVED IN WRITING BY AN AUTHORIZED ST REPRESENTATIVE, ST PRODUCTS ARE NOT RECOMMENDED, AUTHORIZED OR WARRANTED FOR USE IN MILITARY, AIR CRAFT, SPACE, LIFE SAVING, OR LIFE SUSTAINING APPLICATIONS, NOR IN PRODUCTS OR SYSTEMS WHERE FAILURE OR MALFUNCTION MAY RESULT IN PERSONAL INJURY, DEATH, OR SEVERE PROPERTY OR ENVIRONMENTAL DAMAGE. ST PRODUCTS WHICH ARE NOT SPECIFIED AS "AUTOMOTIVE GRADE" MAY ONLY BE USED IN AUTOMOTIVE APPLICATIONS AT USER'S OWN RISK.

Resale of ST products with provisions different from the statements and/or technical features set forth in this document shall immediately void any warranty granted by ST for the ST product or service described herein and shall not create or extend in any manner whatsoever, any liability of ST.

ST and the ST logo are trademarks or registered trademarks of ST in various countries.

Information in this document supersedes and replaces all information previously supplied.

The ST logo is a registered trademark of STMicroelectronics. All other names are the property of their respective owners.

© 2009 STMicroelectronics - All rights reserved

STMicroelectronics group of companies

Australia - Belgium - Brazil - Canada - China - Czech Republic - Finland - France - Germany - Hong Kong - India - Israel - Italy - Japan - Malaysia - Malta - Morocco - Philippines - Singapore - Spain - Sweden - Switzerland - United Kingdom - United States of America

www.st.com





LittleDiode supplies new, hard to find or obsolete electronic components and semiconductors all over the world.

With over two million different components listed you are sure to find the part you need.

Feel free to visit us today at our online store:

LittleDiode.com

Looking forward to providing you with the best possible service.