



## BUL903EDFP

# HIGH VOLTAGE FAST-SWITCHING NPN POWER TRANSISTOR

- INTEGRATED ANTISATURATION AND PROTECTION NETWORK
- INTEGRATED ANTIPARALLEL COLLECTOR EMITTER DIODE
- HIGH VOLTAGE CAPABILITY
- LOW SPREAD OF DYNAMIC PARAMETERS
- MINIMUM LOT-TO-LOT SPREAD FOR RELIABLE OPERATION
- VERY HIGH SWITCHING SPEED
- ARCING TEST SELF PROTECTED
- FULLY INSULATED PACKAGE (U.L. COMPLIANT) FOR EASY MOUNTING

### APPLICATIONS

- FOUR LAMP ELECTRONIC BALLAST FOR 120 V MAINS IN PUSH-PULL CONFIGURATION

### DESCRIPTION

The BUL903EDFP is manufactured using high voltage Multi Epitaxial Planar technology for high switching speeds and high voltage capability.

The device has been designed to operate without baker clamp and transil protection. This enables saving from 2 up to 10 components in the application.

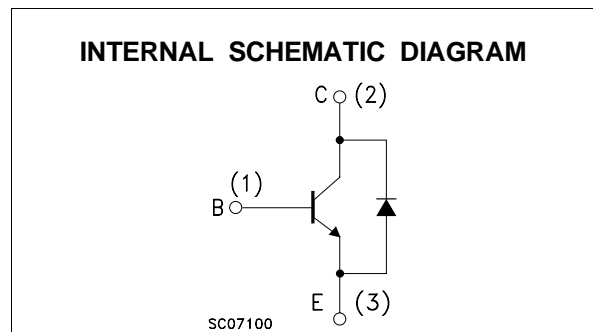
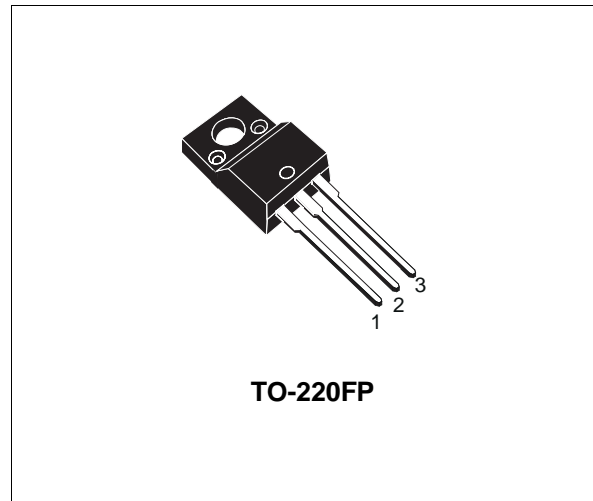

### ABSOLUTE MAXIMUM RATINGS

Symbol	Parameter	Value	Unit
$V_{CES}$	Collector-Emitter Voltage ( $V_{BE} = 0$ )	900	V
$V_{CEO}$	Collector-Emitter Voltage ( $I_B = 0$ )	400	V
$V_{EBO}$	Emitter-Base Voltage ( $I_C = 0$ )	7	V
$I_C$	Collector Current	5	A
$I_{CM}$	Collector Peak Current ( $t_p < 5$ ms)	8	A
$I_B$	Base Current	2	A
$I_{BM}$	Base Peak Current ( $t_p < 5$ ms)	4	A
$P_{tot}$	Total Dissipation at $T_c = 25$ °C	35	W
$V_{isol}$	Insulation Withstand Voltage (RMS) from All Three Leads to External Heatsink	1500	V
$T_{stg}$	Storage Temperature	-65 to 150	°C
$T_j$	Max. Operating Junction Temperature	150	°C

## BUL903EDFP

### THERMAL DATA

R <sub>thj-case</sub>	Thermal Resistance Junction-Case	Max	3.57	°C/W
R <sub>thj-amb</sub>	Thermal Resistance Junction-Ambient	Max	62.5	°C/W

### ELECTRICAL CHARACTERISTICS (T<sub>case</sub> = 25 °C unless otherwise specified)

Symbol	Parameter	Test Conditions	Min.	Typ.	Max.	Unit
I <sub>CES</sub>	Collector Cut-off Current (V <sub>BE</sub> = 0)	V <sub>CE</sub> = 900 V			100	μA
I <sub>EBO</sub>	Emitter Cut-off Current (I <sub>C</sub> = 0)	V <sub>EB</sub> = 7 V			100	μA
V <sub>(BR)CES</sub>	Collector-Emitter Breakdown Voltage (V <sub>BE</sub> = 0)	I <sub>C</sub> = 100 μA	900			V
V <sub>CEO(sus)*</sub>	Collector-Emitter Sustaining Voltage (I <sub>B</sub> = 0)	I <sub>C</sub> = 10 mA    L = 25 mH	400			V
V <sub>CE(sat)*</sub>	Collector-Emitter Saturation Voltage	I <sub>C</sub> = 0.5 A    I <sub>B</sub> = 50 mA I <sub>C</sub> = 1 A        I <sub>B</sub> = 0.15 A I <sub>C</sub> = 2 A        I <sub>B</sub> = 0.4 A			0.5 1 1.5	V V V
V <sub>BE(sat)*</sub>	Base-Emitter Saturation Voltage	I <sub>C</sub> = 0.5 A    I <sub>B</sub> = 50 mA I <sub>C</sub> = 1 A        I <sub>B</sub> = 0.15 A I <sub>C</sub> = 2 A        I <sub>B</sub> = 0.4 A			1 1.1 1.2	V V V
h <sub>FE*</sub>	DC Current Gain	I <sub>C</sub> = 10 mA    V <sub>CE</sub> = 5 V I <sub>C</sub> = 0.25 A    V <sub>CE</sub> = 5 V I <sub>C</sub> = 0.5 A      V <sub>CE</sub> = 5 V I <sub>C</sub> = 2.5 A      V <sub>CE</sub> = 5 V	20 40 28 8		70 60 16	
t <sub>d</sub> t <sub>r</sub> t <sub>s</sub> t <sub>f</sub>	RESISTIVE LOAD Delay Time Rise Time Storage Time Fall Time	V <sub>CC</sub> = 125 V    I <sub>C</sub> = 0.7 A I <sub>B1</sub> = 50 mA    I <sub>B2</sub> = 0.4 A t <sub>p</sub> = 300 μs (see figure 1)			0.2 1 0.8 0.25	μs μs μs μs
E <sub>ar</sub>	Repetitive Avalanche Energy	V <sub>CC</sub> = 50V      C = 1.8 nF V <sub>BE</sub> = -5 V      L = 2 mH (see figure 2)	6			mJ
V <sub>F</sub>	Parallel Diode Forward Voltage	I <sub>F</sub> = 2 A			1.2	V

\* Pulsed: Pulse duration = 300 μs, duty cycle 1.5 %

Safe Operating Area

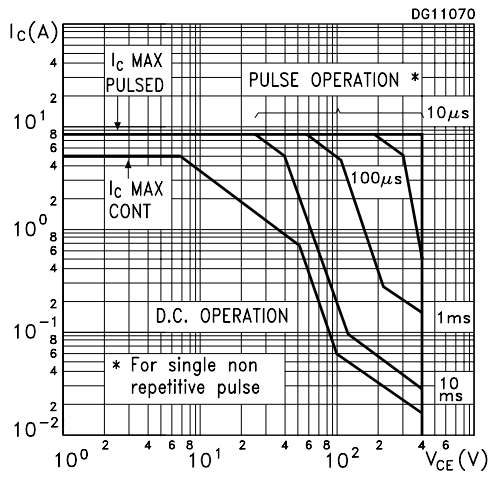

Derating Curve

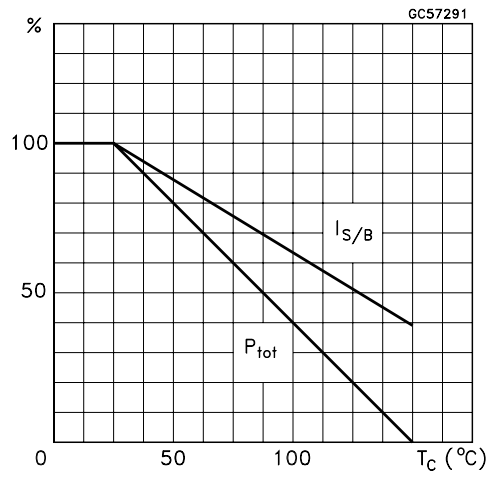

Output Characteristics

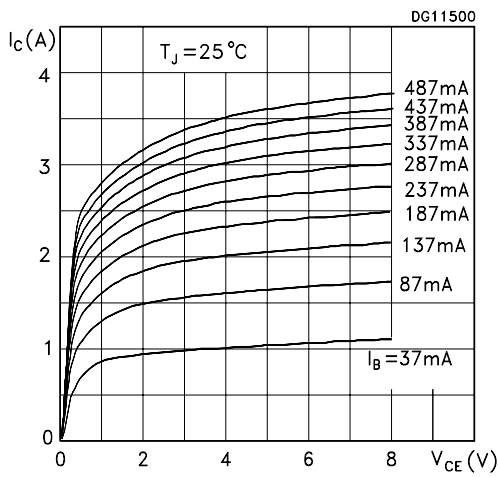

DC Current Gain

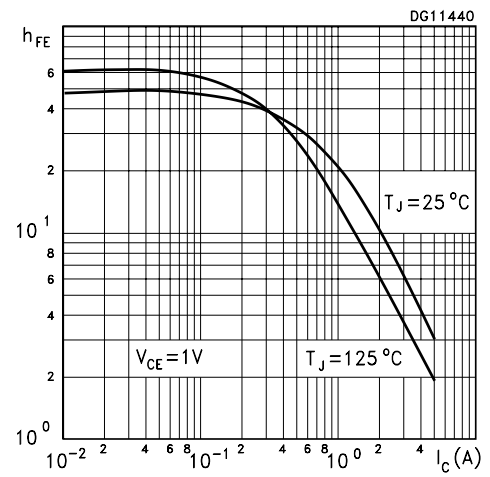

DC Current Gain

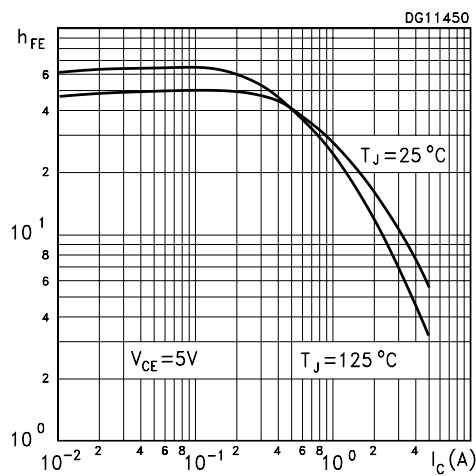

Collector Emitter Saturation Voltage

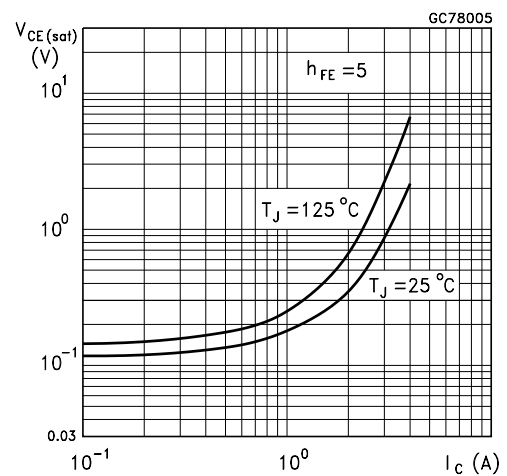

**Base Emitter Saturation Voltage**

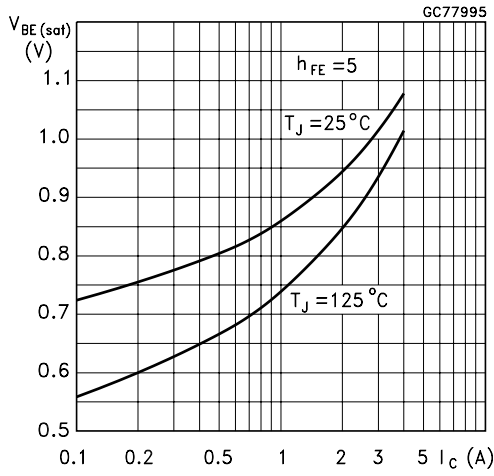

**Switching Times Resistive Load**

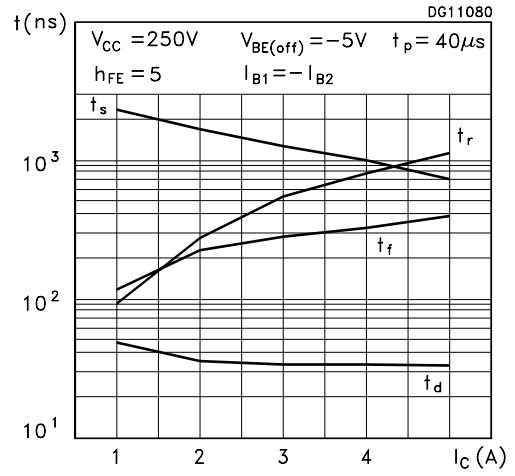

**Switching Times Inductive Load**

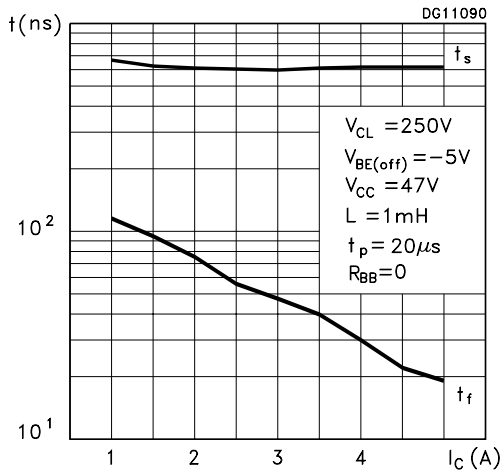

**Reverse Biased SOA**

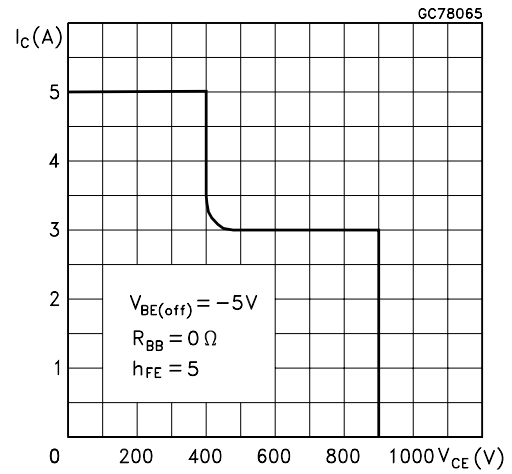

Figure 1: Resistive Load Switching Test Circuit

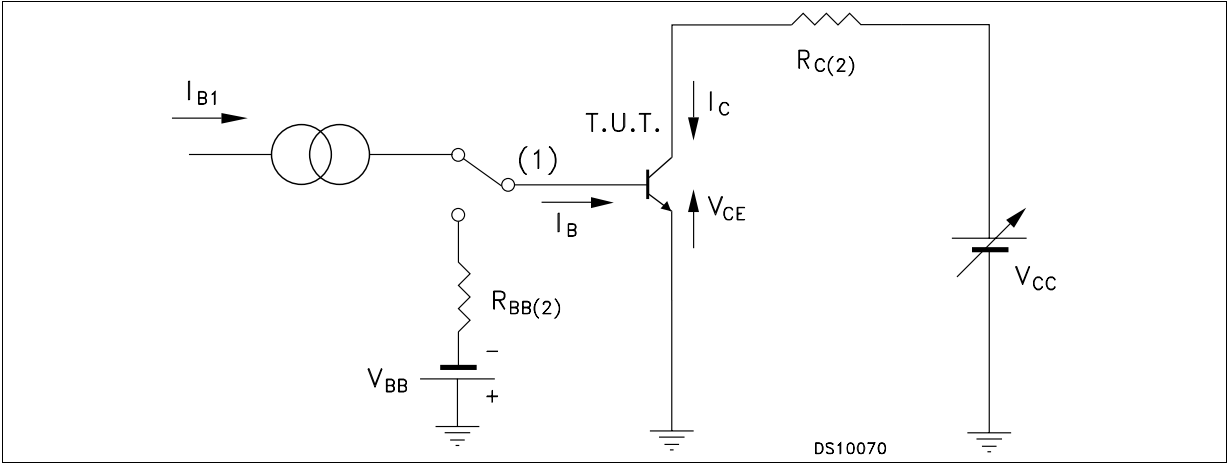

Figure 2 : Energy Rating Test Circuit

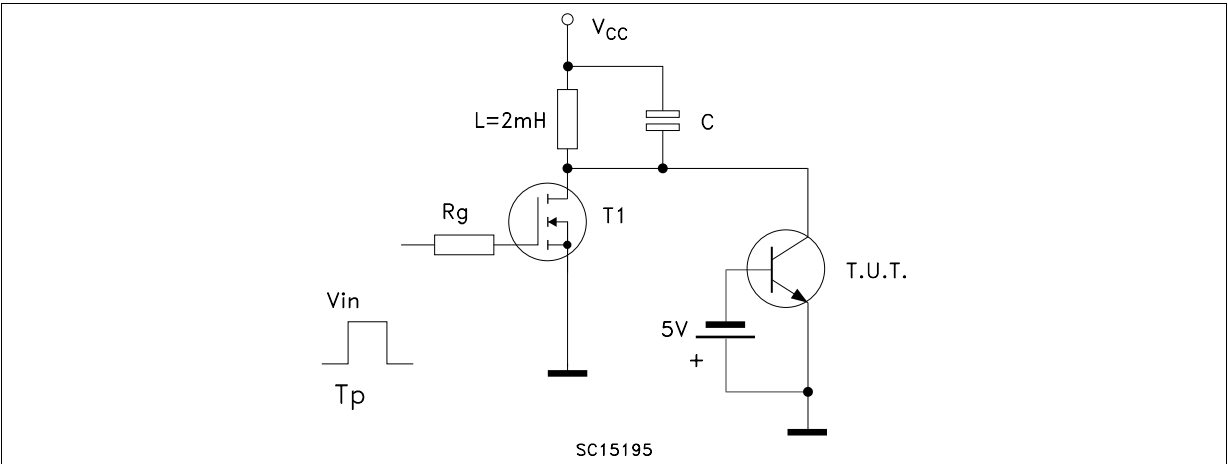
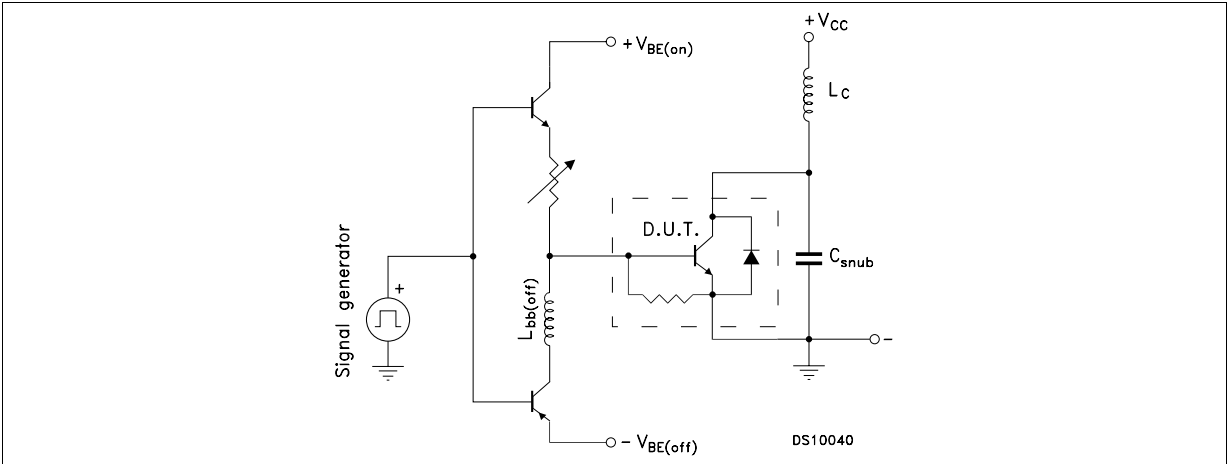
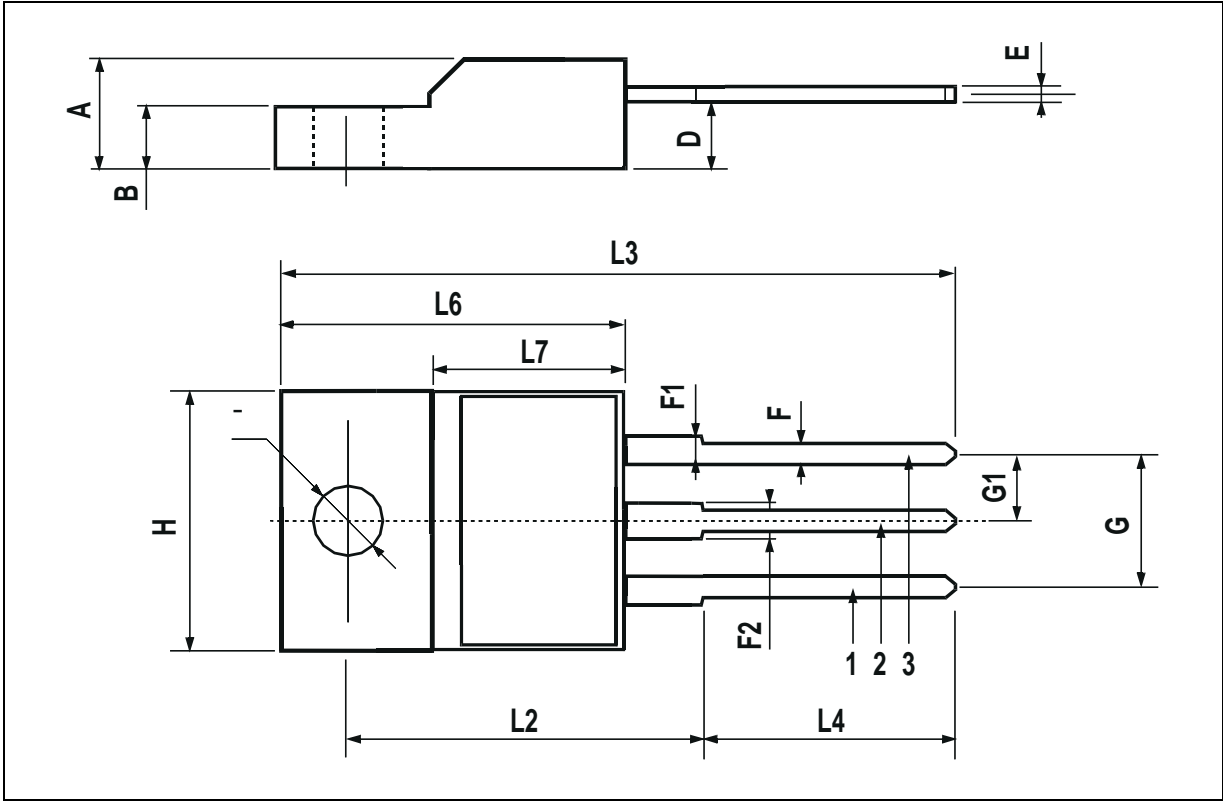

Figure 3: Inductive Load Switching Test Circuit



**TO-220FP MECHANICAL DATA**

DIM.	mm			inch		
	MIN.	TYP.	MAX.	MIN.	TYP.	MAX.
A	4.4		4.6	0.173		0.181
B	2.5		2.7	0.098		0.106
D	2.5		2.75	0.098		0.108
E	0.45		0.7	0.017		0.027
F	0.75		1	0.030		0.039
F1	1.15		1.7	0.045		0.067
F2	1.15		1.7	0.045		0.067
G	4.95		5.2	0.195		0.204
G1	2.4		2.7	0.094		0.106
H	10		10.4	0.393		0.409
L2		16			0.630	
L3	28.6		30.6	1.126		1.204
L4	9.8		10.6	0.385		0.417
L6	15.9		16.4	0.626		0.645
L7	9		9.3	0.354		0.366
Ø	3		3.2	0.118		0.126



Information furnished is believed to be accurate and reliable. However, STMicroelectronics assumes no responsibility for the consequences of use of such information nor for any infringement of patents or other rights of third parties which may result from its use. No license is granted by implication or otherwise under any patent or patent rights of STMicroelectronics. Specification mentioned in this publication are subject to change without notice. This publication supersedes and replaces all information previously supplied. STMicroelectronics products are not authorized for use as critical components in life support devices or systems without express written approval of STMicroelectronics.

The ST logo is a trademark of STMicroelectronics.

All other names are the property of their respective owners.

© 2003 STMicroelectronics – All Rights reserved

STMicroelectronics GROUP OF COMPANIES

Australia - Belgium - Brazil - Canada - China - Czech Republic - Finland - France - Germany - Hong Kong - India - Israel - Italy - Japan - Malaysia - Malta - Morocco - Singapore - Spain - Sweden - Switzerland - United Kingdom - United States.

<http://www.st.com>



LittleDiode supplies new, hard to find or obsolete electronic components and semiconductors all over the world.

With over two million different components listed you are sure to find the part you need.

Feel free to visit us today at our online store:

[LittleDiode.com](http://LittleDiode.com)

Looking forward to providing you with the best possible service.