

## NPN Silicon RF Transistor

**BFQ 73S**

- For low-noise, low-distortion broadband amplifiers in antenna and telecommunications systems up to 2 GHz at collector currents from 10 mA to 70 mA.
- Hermetically sealed ceramic package.
- HiRel/Mil screening available.
- CECC-type available: CECC 50002/261.

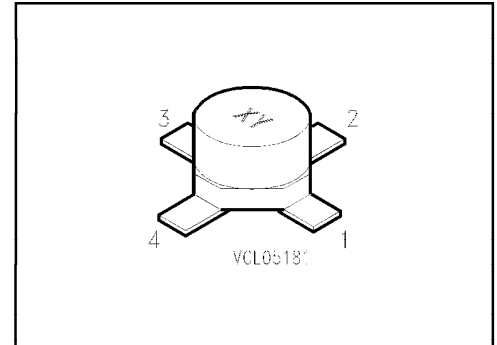

**ESD: Electrostatic discharge sensitive device, observe handling precautions!**

| Type    | Marking | Ordering Code<br>(tape and reel) | Pin Configuration |   |   |   | Package <sup>1)</sup> |
|---------|---------|----------------------------------|-------------------|---|---|---|-----------------------|
|         |         |                                  | 1                 | 2 | 3 | 4 |                       |
| BFQ 73S | 73S     | Q62702-F1104                     | B                 | E | C | E | Cerrec-X              |

### Maximum Ratings

| Parameter  | Symbol    | Values         | Unit |
|--|-----------|----------------|------|
| Collector-emitter voltage                            | $V_{CE0}$ | 15             | V    |
| Collector-base voltage                               | $V_{CB0}$ | 20             |      |
| Emitter-base voltage                                 | $V_{EB0}$ | 3              |      |
| Collector current                                    | $I_C$     | 100            | mA   |
| Total power dissipation, $T_s \leq 110\text{ °C}^3)$ | $P_{tot}$ | 500            | mW   |
| Junction temperature                                 | $T_j$     | 175            | °C   |
| Ambient temperature range                            | $T_A$     | - 65 ... + 175 |      |
| Storage temperature range                            | $T_{stg}$ | - 65 ... + 175 |      |

### Thermal Resistance

|  |              |            |     |
|--|--------------|------------|-----|
| Junction - ambient <sup>2)</sup>         | $R_{th\ JA}$ | $\leq 210$ | K/W |
| Junction - soldering point <sup>3)</sup> | $R_{th\ JS}$ | $\leq 130$ |     |

1) For detailed information see chapter Package Outlines.

2) Package mounted on alumina  $15\text{ mm} \times 16.7\text{ mm} \times 0.7\text{ mm}$ .

3)  $T_s$  is measured on the collector lead at the soldering point to the pcb.

**Electrical Characteristics**at  $T_A = 25\text{ °C}$ , unless otherwise specified.

| Parameter | Symbol | Values |      |      | Unit |
|-----------|--------|--------|------|------|------|
|           |        | min.   | typ. | max. |      |

**DC Characteristics**

|  |               |    |     |     |               |
|--|---------------|----|-----|-----|---------------|
| Collector-emitter breakdown voltage<br>$I_C = 1\text{ mA}$ , $I_B = 0$               | $V_{(BR)CE0}$ | 15 | –   | –   | V             |
| Collector-base cutoff current<br>$V_{CB} = 10\text{ V}$ , $I_E = 0$                  | $I_{CB0}$     | –  | –   | 100 | nA            |
| Emitter-base cutoff current<br>$V_{EB} = 2\text{ V}$ , $I_C = 0$                     | $I_{EB0}$     | –  | –   | 10  | $\mu\text{A}$ |
| DC current gain<br>$I_C = 50\text{ mA}$ , $V_{CE} = 5\text{ V}$                      | $h_{FE}$      | 30 | 90  | 250 | –             |
| Collector-emitter saturation voltage<br>$I_C = 75\text{ mA}$ , $I_B = 7.5\text{ mA}$ | $V_{CEsat}$   | –  | 0.2 | 0.5 | V             |

## Electrical Characteristics

at  $T_A = 25\text{ }^\circ\text{C}$ , unless otherwise specified.

| Parameter | Symbol | Values |      |      | Unit |
|-----------|--------|--------|------|------|------|
|           |        | min.   | typ. | max. |      |

## AC Characteristics

|   |                   |   |            |   |     |
|---|-------------------|---|------------|---|-----|
| Transition frequency<br>$I_C = 50\text{ mA}$ , $V_{CE} = 5\text{ V}$ , $f = 200\text{ MHz}$<br>$I_C = 75\text{ mA}$ , $V_{CE} = 5\text{ V}$ , $f = 200\text{ MHz}$  | $f$               | – | 5.3<br>5.4 | – | GHz |
| Collector-base capacitance<br>$V_{CB} = 10\text{ V}$ , $V_{BE} = v_{be} = 0$ , $f = 1\text{ MHz}$   | $C_{cb}$          | – | 0.9        | – | pF  |
| Collector-emitter capacitance<br>$V_{CE} = 10\text{ V}$ , $V_{BE} = v_{be} = 0$ , $f = 1\text{ MHz}$  | $C_{ce}$          | – | 0.4        | – |     |
| Input capacitance<br>$V_{EB} = 0.5\text{ V}$ , $I_C = i_c = 0$ , $f = 1\text{ MHz}$   | $C_{ibo}$         | – | 5          | – |     |
| Output capacitance<br>$V_{CE} = 10\text{ V}$ , $V_{BE} = v_{be} = 0$ , $f = 1\text{ MHz}$   | $C_{obs}$         | – | 1.3        | – |     |
| Noise figure<br>$I_C = 5\text{ mA}$ , $V_{CE} = 10\text{ V}$ , $f = 10\text{ MHz}$ , $Z_S = 50\text{ }\Omega$<br>$I_C = 50\text{ mA}$ , $V_{CE} = 5\text{ V}$ , $f = 800\text{ MHz}$ , $Z_S = Z_{Sopt}$               | $F$               | – | 0.9<br>2.5 | – | dB  |
| Power gain<br>$I_C = 50\text{ mA}$ , $V_{CE} = 5\text{ V}$ , $f = 800\text{ MHz}$ ,<br>$Z_S = Z_{Sopt}$ , $Z_L = Z_{Lopt}$  | $G_{pe}$          | – | 15         | – |     |
| Transducer gain<br>$I_C = 50\text{ mA}$ , $V_{CE} = 5\text{ V}$ , $f = 1\text{ GHz}$ , $Z_0 = 50\text{ }\Omega$   | $ S_{21e} ^2$     | – | 10.5       | – |     |
| Linear output voltage<br>two-tone intermodulation test<br>$I_C = 50\text{ mA}$ , $V_{CE} = 10\text{ V}$ , $d_{IM} = 60\text{ dB}$<br>$f_1 = 806\text{ MHz}$ , $f_2 = 810\text{ MHz}$ , $Z_S = Z_L = 50\text{ }\Omega$ | $V_{o1} = V_{o2}$ | – | 400        | – | mV  |
| Third order intercept point<br>$I_C = 50\text{ mA}$ , $V_{CE} = 10\text{ V}$ , $f = 800\text{ MHz}$   | $IP_3$            | – | 35         | – | dBm |

**Total power dissipation  $P_{tot} = f(T_A^*; T_S)$**

\* Package mounted on alumina

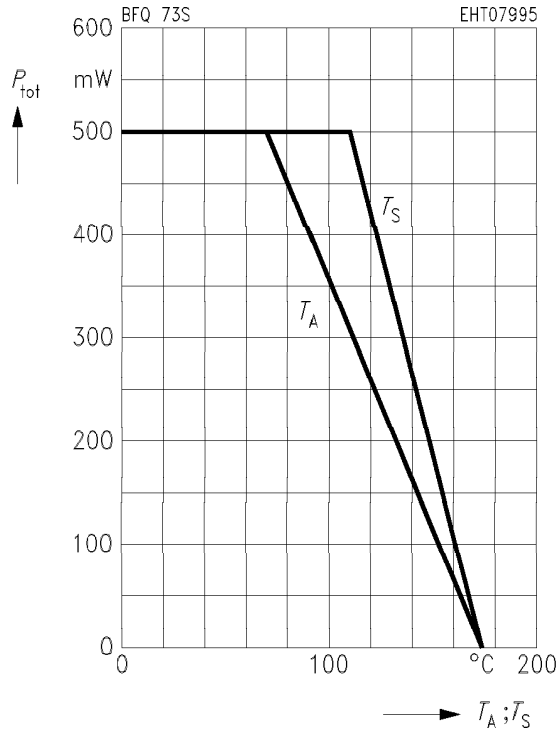

**Transition frequency  $f_T = f(I_C)$**

$V_{CE} = 5 \text{ V}, f = 200 \text{ MHz}$

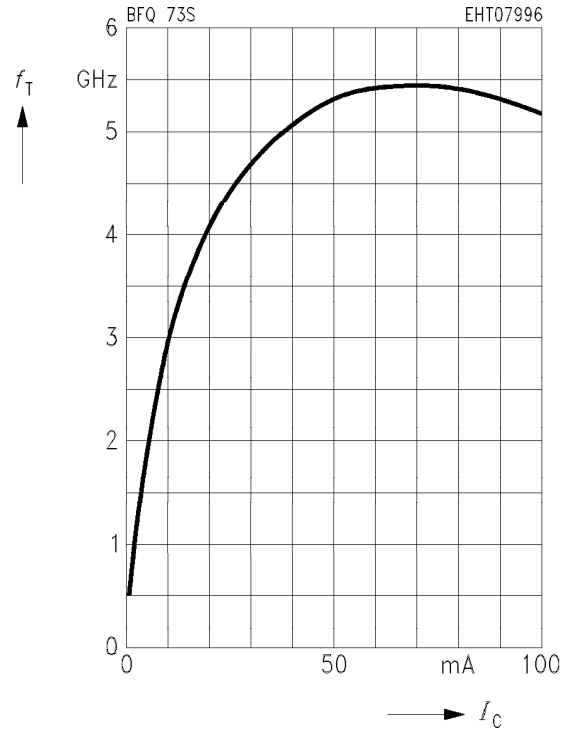

**Collector-base capacitance  $C_{cb} = f(V_{CB})$**

$V_{BE} = v_{be} = 0, f = 1 \text{ MHz}$

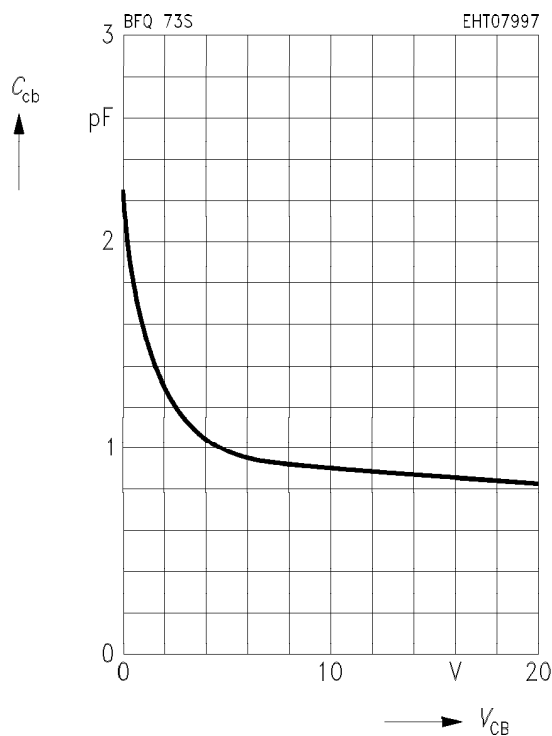

### Common Emitter Noise Parameters

| $f$ | $F_{min}$ | $G_p(F_{min})$ | $\Gamma_{opt}$ |     | $R_N$    | $N$ | $F_{50\Omega}$ | $G_p(F_{50\Omega})$ |
|-----|-----------|----------------|----------------|-----|----------|-----|----------------|---------------------|
| GHz | dB        | dB             | MAG            | ANG | $\Omega$ | —   | dB             | dB                  |

$I_C = 5 \text{ mA}, V_{CE} = 5 \text{ V}, Z_0 = 50 \Omega$

|      |     |   |                         |  |   |   |   |   |
|------|-----|---|-------------------------|--|---|---|---|---|
| 0.01 | 0.9 | — | (Z <sub>s</sub> = 50 Ω) |  | — | — | — | — |
|------|-----|---|-------------------------|--|---|---|---|---|

$I_C = 50 \text{ mA}, V_{CE} = 5 \text{ V}, Z_0 = 50 \Omega$

|      |     |    |                         |     |   |      |     |   |
|------|-----|----|-------------------------|-----|---|------|-----|---|
| 0.01 | 2.0 | —  | (Z <sub>s</sub> = 50 Ω) |     | — | —    | —   | — |
| 0.8  | 2.5 | 14 | 0.41                    | 163 | 9 | 0.39 | 3.8 | — |

### Noise figure $F = f(I_C)$

$V_{CE} = 10 \text{ V}, f = 10 \text{ MHz}, Z_S = 50 \Omega$

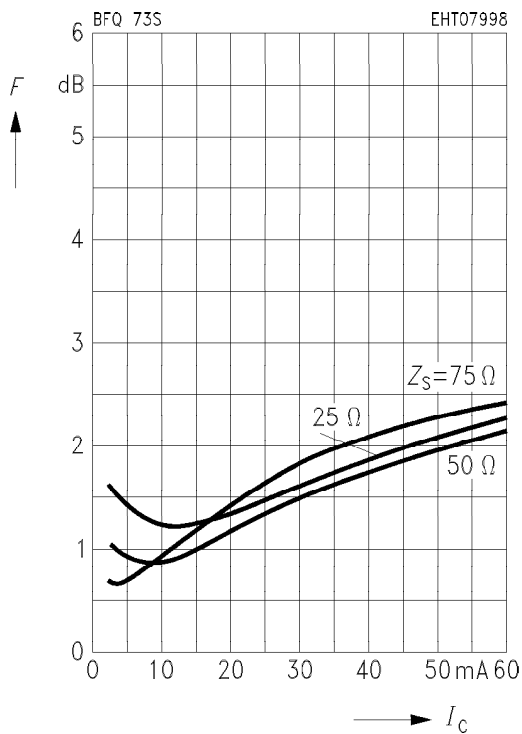

### Noise figure $F = f(I_C)$

$V_{CE} = 5 \text{ V}, f = 800 \text{ MHz}$

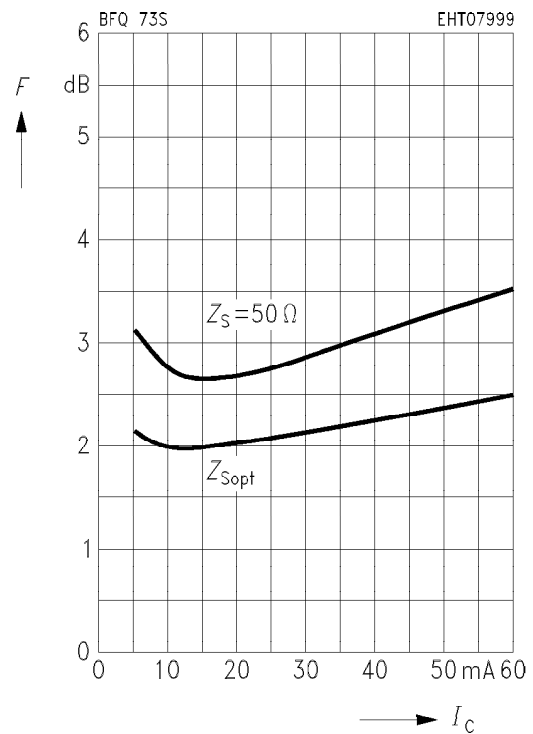

**Circles of constant noise figure  $F = f(Z_s)$   
and available power gain  $G_{av} = f(Z_s)$**

$I_C = 50 \text{ mA}$ ,  $V_{CE} = 5 \text{ V}$ ,  $f = 800 \text{ MHz}$ ,  
 $Z_0 = 50 \Omega$

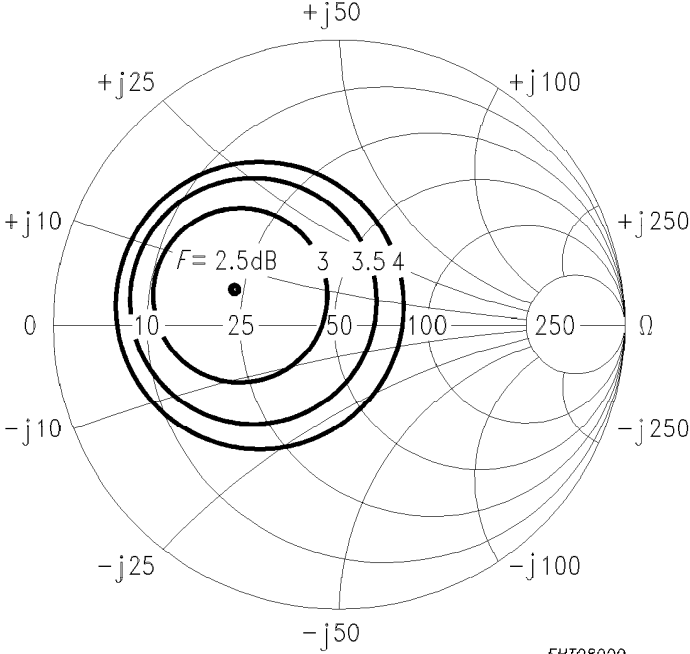

**Common Emitter Power Gain**

**Power gain  $G_{ms}$ ,  $|S_{21e}|^2 = f(I_c)$**   
 $V_{CE} = 5 \text{ V}, f = 200 \text{ MHz}, Z_0 = 50 \Omega$

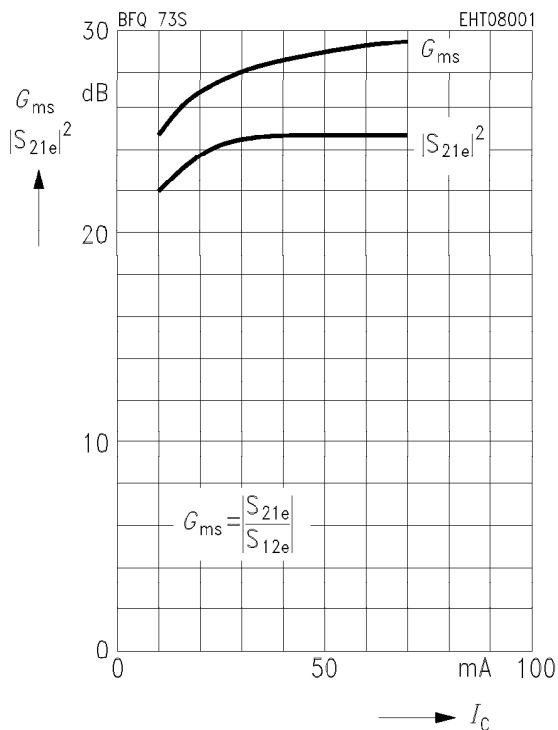

**Power gain  $G_{ms}$ ,  $|S_{21e}|^2 = f(I_c)$**   
 $V_{CE} = 5 \text{ V}, f = 500 \text{ MHz}, Z_0 = 50 \Omega$

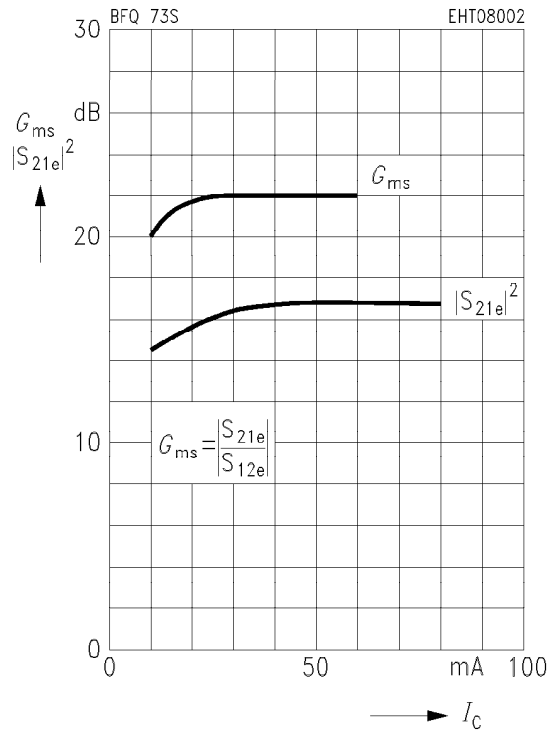

**Power gain  $G_{ma}$ ,  $|S_{21e}|^2 = f(I_c)$**   
 $V_{CE} = 5 \text{ V}, f = 800 \text{ MHz}, Z_0 = 50 \Omega$

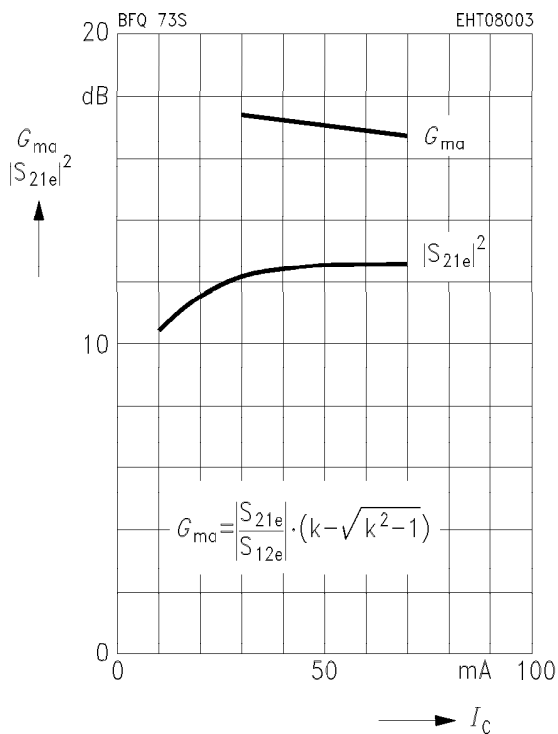

**Power gain  $G_{ma}$ ,  $|S_{21e}|^2 = f(I_c)$**   
 $V_{CE} = 5 \text{ V}, f = 1.5 \text{ GHz}, Z_0 = 50 \Omega$

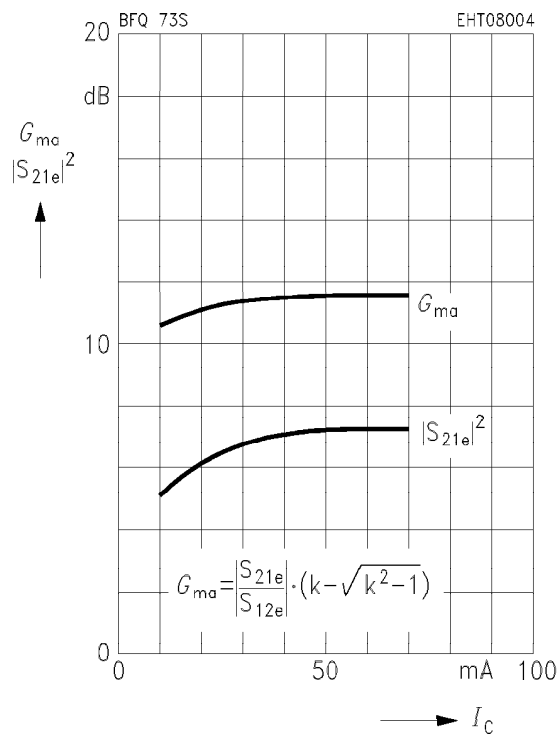

**Power gain  $G_{ma}$ ,  $G_{ms}$ ,  $|S_{21e}|^2 = f(f)$**   
 $I_C = 10 \text{ mA}$ ,  $V_{CE} = 5 \text{ V}$ ,  $Z_0 = 50 \Omega$

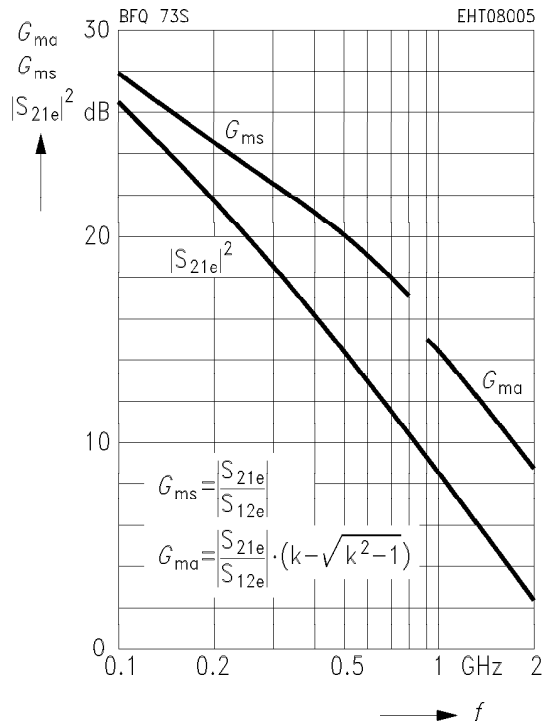

**Power gain  $G_{ma}$ ,  $G_{ms}$ ,  $|S_{21e}|^2 = f(f)$**   
 $I_C = 30 \text{ mA}$ ,  $V_{CE} = 5 \text{ V}$ ,  $Z_0 = 50 \Omega$

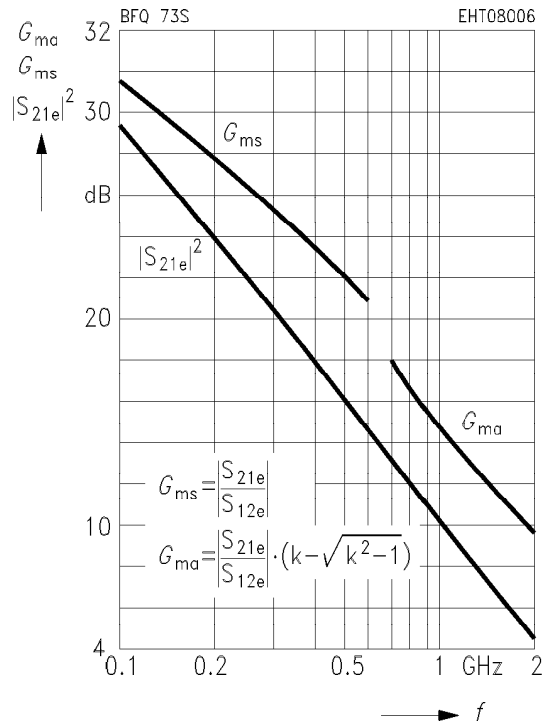

**Power gain  $G_{ma}$ ,  $G_{ms}$ ,  $|S_{21e}|^2 = f(f)$**   
 $I_C = 50 \text{ mA}$ ,  $V_{CE} = 5 \text{ V}$ ,  $Z_0 = 50 \Omega$

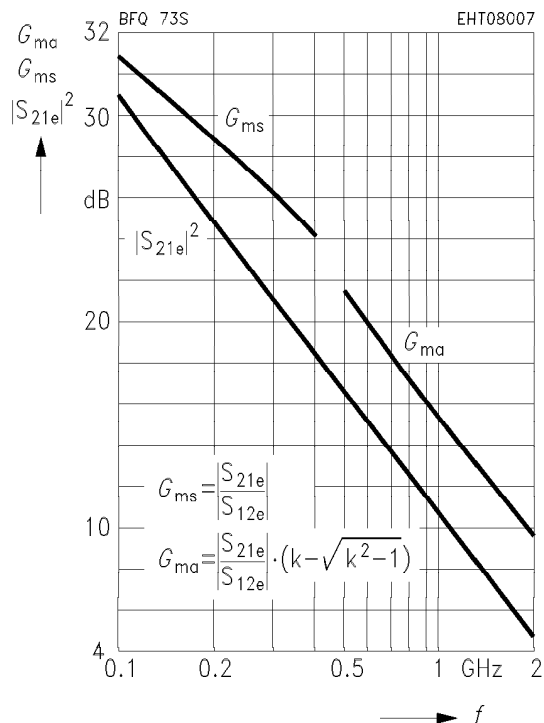

**Power gain  $G_{ma}$ ,  $G_{ms}$ ,  $|S_{21e}|^2 = f(f)$**   
 $I_C = 70 \text{ mA}$ ,  $V_{CE} = 5 \text{ V}$ ,  $Z_0 = 50 \Omega$

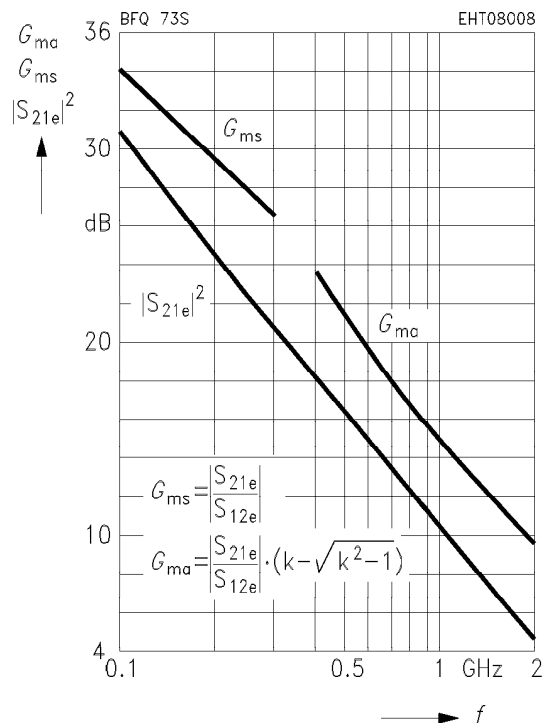

### Common Emitter S Parameters

| $f$  | $S_{11}$ |       | $S_{21}$ |     | $S_{12}$ |     | $S_{22}$ |       |
|--|----------|-------|----------|-----|----------|-----|----------|-------|
| GHz  | MAG      | ANG   | MAG      | ANG | MAG      | ANG | MAG      | ANG   |
| $I_C = 10 \text{ mA}, V_{CE} = 5 \text{ V}, Z_0 = 50 \Omega$ |          |       |          |     |          |     |          |       |
| 0.1  | 0.78     | - 92  | 20.39    | 132 | 0.034    | 48  | 0.71     | - 39  |
| 0.3  | 0.75     | - 152 | 8.63     | 97  | 0.047    | 30  | 0.34     | - 57  |
| 0.5  | 0.75     | - 169 | 5.27     | 84  | 0.053    | 31  | 0.26     | - 61  |
| 0.8  | 0.75     | 177   | 3.29     | 71  | 0.060    | 35  | 0.23     | - 68  |
| 1.0  | 0.76     | 171   | 2.63     | 63  | 0.066    | 39  | 0.22     | - 73  |
| 1.2  | 0.77     | 165   | 2.21     | 57  | 0.073    | 42  | 0.22     | - 79  |
| 1.4  | 0.77     | 159   | 1.91     | 50  | 0.081    | 43  | 0.23     | - 84  |
| 1.6  | 0.77     | 155   | 1.68     | 44  | 0.089    | 45  | 0.24     | - 91  |
| 1.8  | 0.78     | 151   | 1.49     | 38  | 0.098    | 45  | 0.25     | - 98  |
| 2.0  | 0.79     | 147   | 1.34     | 32  | 0.107    | 46  | 0.26     | - 106 |

$S_{11}, S_{22} = f(f)$

$I_C = 10 \text{ mA}, V_{CE} = 5 \text{ V}, Z_0 = 50 \Omega$

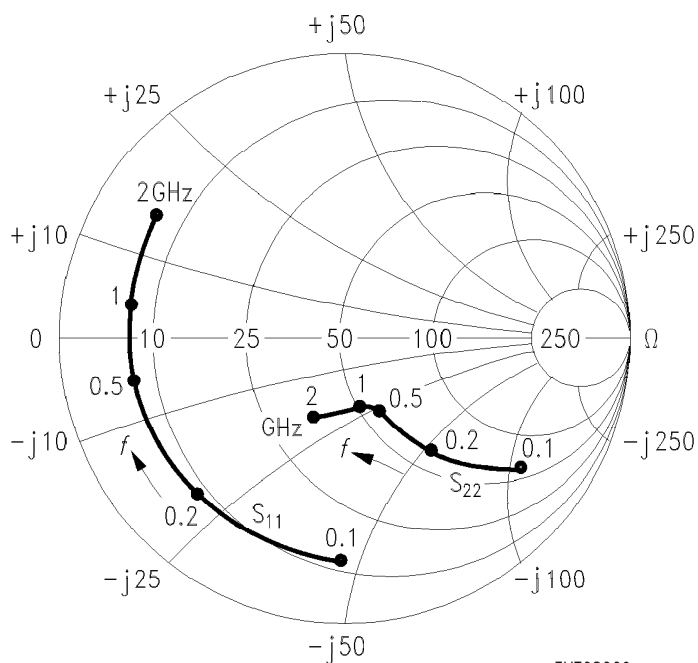

EHT08009

$S_{12}, S_{21} = f(f)$

$I_C = 10 \text{ mA}, V_{CE} = 5 \text{ V}, Z_0 = 50 \Omega$

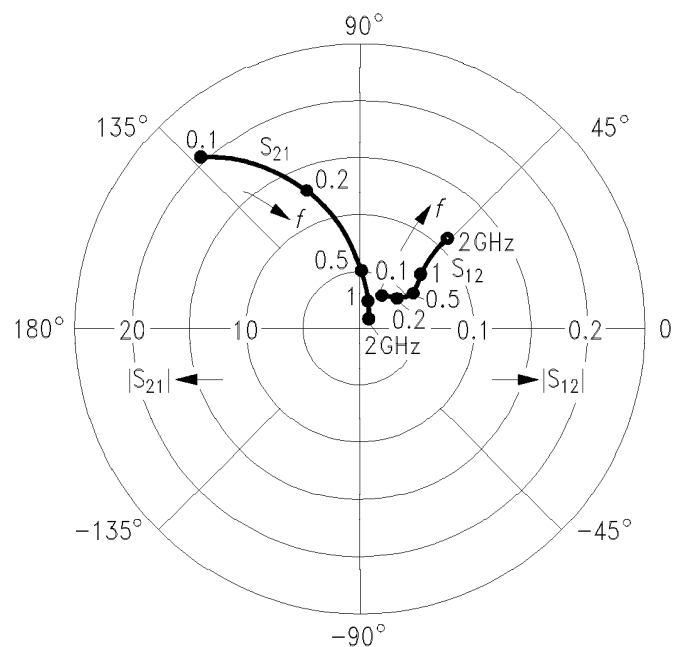

EHT08010

Common Emitter S Parameters (continued)

| $f$  | $S_{11}$ |       | $S_{21}$ |     | $S_{12}$ |     | $S_{22}$ |       |
|--|----------|-------|----------|-----|----------|-----|----------|-------|
| GHz  | MAG      | ANG   | MAG      | ANG | MAG      | ANG | MAG      | ANG   |
| $I_C = 30 \text{ mA}, V_{CE} = 5 \text{ V}, Z_0 = 50 \Omega$ |          |       |          |     |          |     |          |       |
| 0.1  | 0.72     | - 30  | 31.12    | 117 | 0.022    | 44  | 0.49     | - 66  |
| 0.3  | 0.73     | - 168 | 11.01    | 91  | 0.029    | 45  | 0.20     | - 103 |
| 0.5  | 0.74     | - 179 | 6.61     | 82  | 0.040    | 51  | 0.15     | - 119 |
| 0.8  | 0.73     | 170   | 4.10     | 71  | 0.056    | 55  | 0.14     | - 132 |
| 1.0  | 0.75     | 166   | 3.27     | 64  | 0.067    | 56  | 0.13     | - 139 |
| 1.2  | 0.75     | 161   | 2.75     | 59  | 0.079    | 56  | 0.13     | - 144 |
| 1.4  | 0.76     | 156   | 2.38     | 53  | 0.090    | 55  | 0.14     | - 146 |
| 1.6  | 0.75     | 152   | 2.09     | 47  | 0.102    | 54  | 0.14     | - 148 |
| 1.8  | 0.76     | 149   | 1.85     | 41  | 0.113    | 52  | 0.16     | - 152 |
| 2.0  | 0.78     | 145   | 1.67     | 36  | 0.123    | 51  | 0.17     | - 157 |

$S_{11}, S_{22} = f(f)$   
 $I_C = 30 \text{ mA}, V_{CE} = 5 \text{ V}, Z_0 = 50 \Omega$

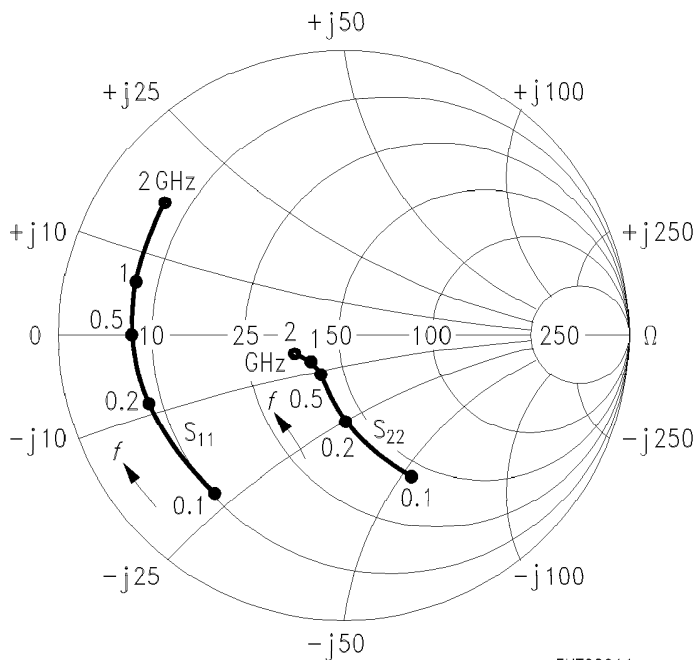

EHT08011

$S_{12}, S_{21} = f(f)$   
 $I_C = 30 \text{ mA}, V_{CE} = 5 \text{ V}, Z_0 = 50 \Omega$

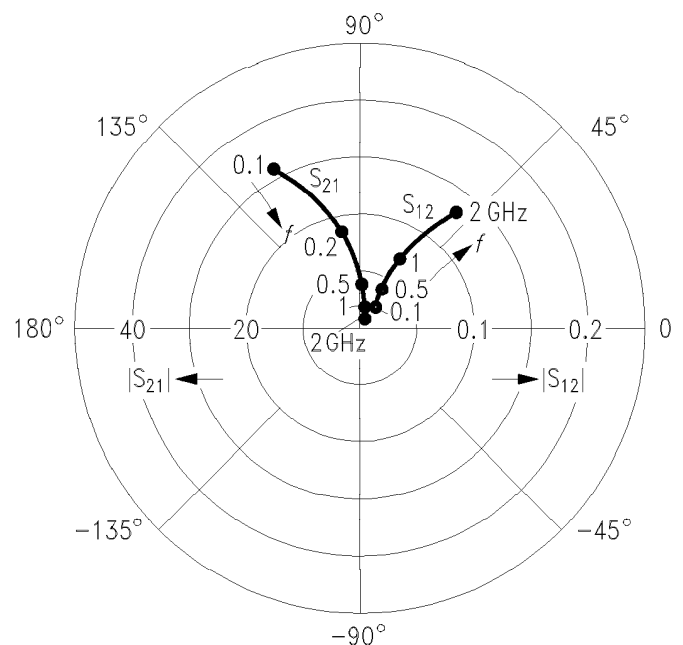

EHT08012

### Common Emitter S Parameters (continued)

| $f$ | $S_{11}$ |      | $S_{21}$ |     | $S_{12}$ |     | $S_{22}$ |      |
|-----|----------|------|----------|-----|----------|-----|----------|------|
|     | MAG      | ANG  | MAG      | ANG | MAG      | ANG | MAG      | ANG  |
| 0.1 | 0.72     | -142 | 33.86    | 111 | 0.018    | 43  | 0.42     | -79  |
| 0.3 | 0.73     | -173 | 11.49    | 90  | 0.027    | 52  | 0.19     | -122 |
| 0.5 | 0.73     | 177  | 6.87     | 81  | 0.038    | 58  | 0.16     | -139 |
| 0.8 | 0.73     | 169  | 4.25     | 70  | 0.056    | 60  | 0.15     | -152 |
| 1.0 | 0.75     | 165  | 3.39     | 64  | 0.068    | 60  | 0.15     | -158 |
| 1.2 | 0.75     | 160  | 2.85     | 59  | 0.080    | 59  | 0.15     | -162 |
| 1.4 | 0.75     | 155  | 2.46     | 53  | 0.092    | 58  | 0.15     | -165 |
| 1.6 | 0.75     | 152  | 2.16     | 48  | 0.105    | 56  | 0.16     | -166 |
| 1.8 | 0.75     | 148  | 1.92     | 42  | 0.116    | 53  | 0.17     | -169 |
| 2.0 | 0.78     | 144  | 1.72     | 37  | 0.126    | 52  | 0.18     | -172 |

$I_C = 50 \text{ mA}, V_{CE} = 5 \text{ V}, Z_0 = 50 \Omega$

$S_{11}, S_{22} = f(f)$   
 $I_C = 50 \text{ mA}, V_{CE} = 5 \text{ V}, Z_0 = 50 \Omega$

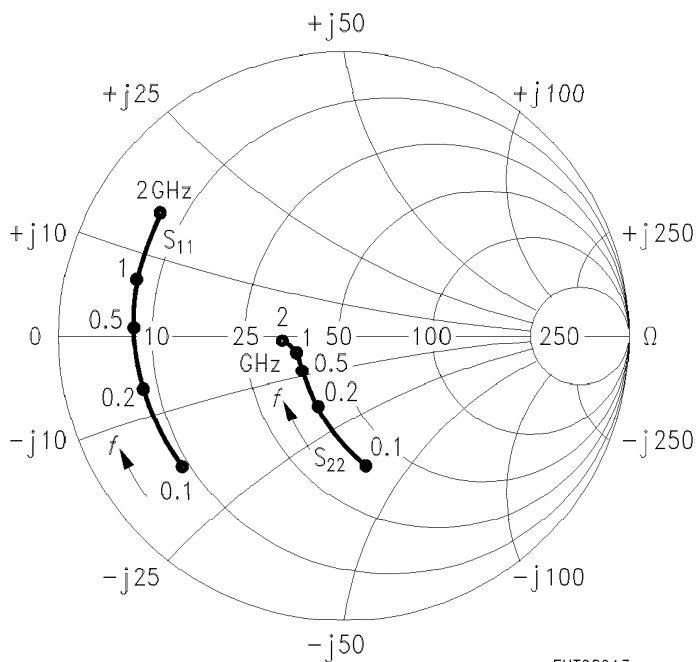

EHT08013

$S_{12}, S_{21} = f(f)$   
 $I_C = 50 \text{ mA}, V_{CE} = 5 \text{ V}, Z_0 = 50 \Omega$

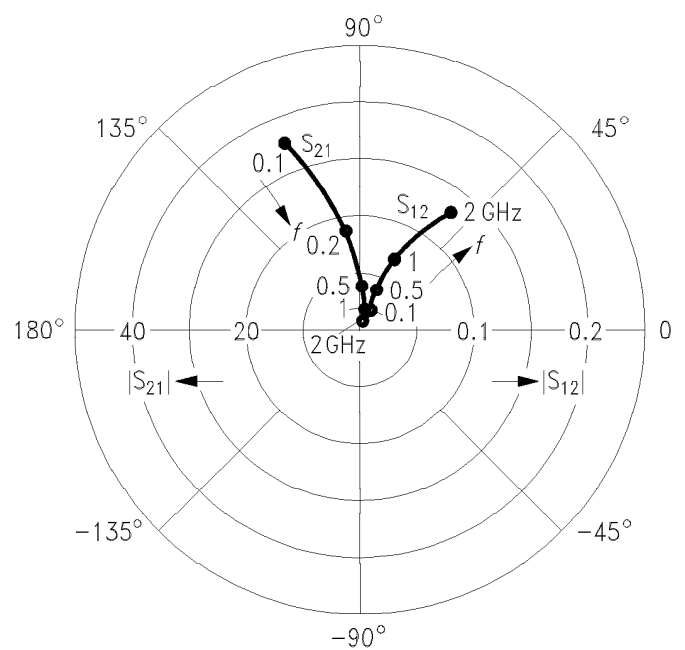

EHT08014

### Common Emitter S Parameters (continued)

| <i>f</i>  | <i>S</i> <sub>11</sub> |      | <i>S</i> <sub>21</sub> |     | <i>S</i> <sub>12</sub> |     | <i>S</i> <sub>22</sub> |      |
|---|------------------------|------|------------------------|-----|------------------------|-----|------------------------|------|
|   | MAG                    | ANG  | MAG                    | ANG | MAG                    | ANG | MAG                    | ANG  |
| <i>I</i> <sub>C</sub> = 70 mA, <i>V</i> <sub>CE</sub> = 5 V, <i>Z</i> <sub>0</sub> = 50 Ω |                        |      |                        |     |                        |     |                        |      |
| 0.1   | 0.72                   | -149 | 34.51                  | 108 | 0.014                  | 42  | 0.37                   | -87  |
| 0.3   | 0.73                   | -175 | 11.47                  | 89  | 0.025                  | 56  | 0.18                   | -130 |
| 0.5   | 0.73                   | 176  | 6.84                   | 80  | 0.037                  | 62  | 0.16                   | -146 |
| 0.8   | 0.74                   | 168  | 4.24                   | 70  | 0.056                  | 63  | 0.16                   | -157 |
| 1.0   | 0.75                   | 164  | 3.38                   | 64  | 0.069                  | 62  | 0.16                   | -163 |
| 1.2   | 0.75                   | 159  | 2.84                   | 59  | 0.081                  | 61  | 0.16                   | -167 |
| 1.4   | 0.76                   | 155  | 2.45                   | 53  | 0.093                  | 59  | 0.16                   | -170 |
| 1.6   | 0.75                   | 151  | 2.15                   | 48  | 0.105                  | 57  | 0.16                   | -171 |
| 1.8   | 0.77                   | 148  | 1.91                   | 42  | 0.177                  | 54  | 0.17                   | -173 |
| 2.0   | 0.78                   | 144  | 1.71                   | 38  | 0.127                  | 52  | 0.18                   | -177 |

*S*<sub>11</sub>, *S*<sub>22</sub> = *f*(*f*)  
*I*<sub>C</sub> = 70 mA, *V*<sub>CE</sub> = 5 V, *Z*<sub>0</sub> = 50 Ω

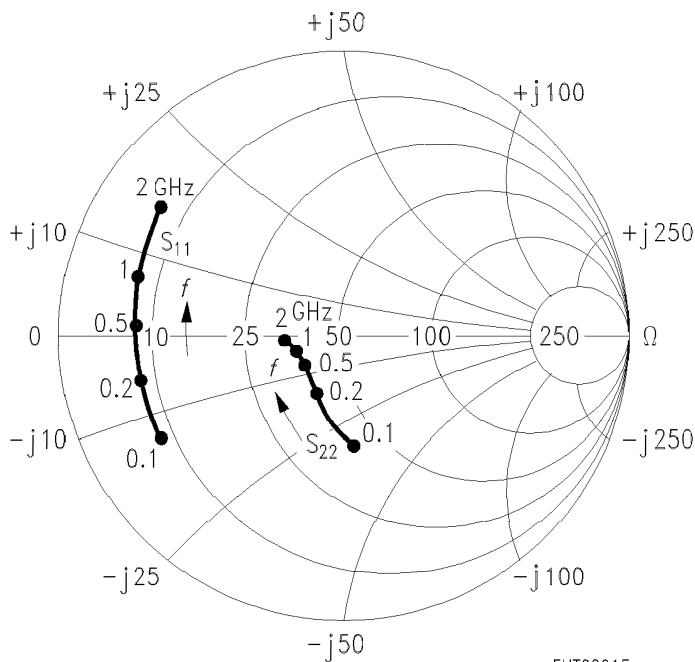

EHT08015

*S*<sub>12</sub>, *S*<sub>21</sub> = *f*(*f*)  
*I*<sub>C</sub> = 70 mA, *V*<sub>CE</sub> = 5 V, *Z*<sub>0</sub> = 50 Ω

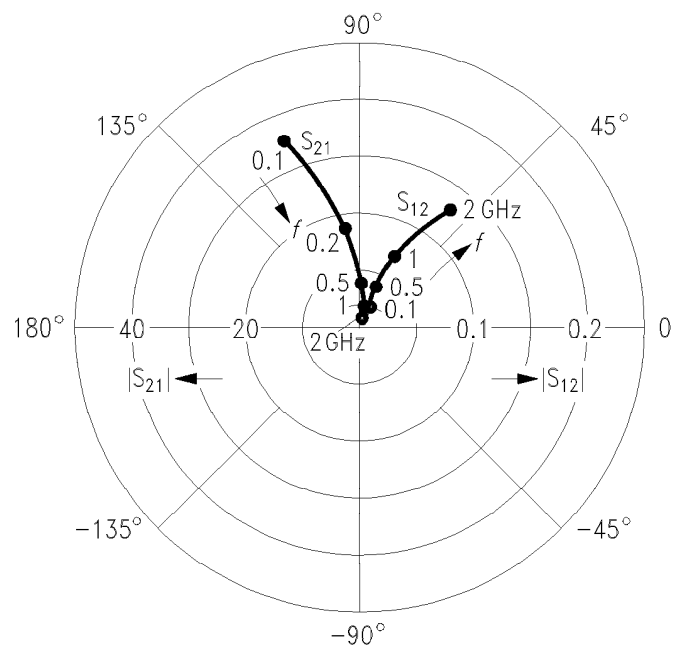

EHT08016

**Common Emitter Large Signal Parameters**

**Linear output voltage  $V_o = f(I_c)$**

$d_{IM} = 60$  dB,  $f_1 = 806$  MHz,  
 $f_2 = 810$  MHz,  $Z_s = Z_L = 50 \Omega$

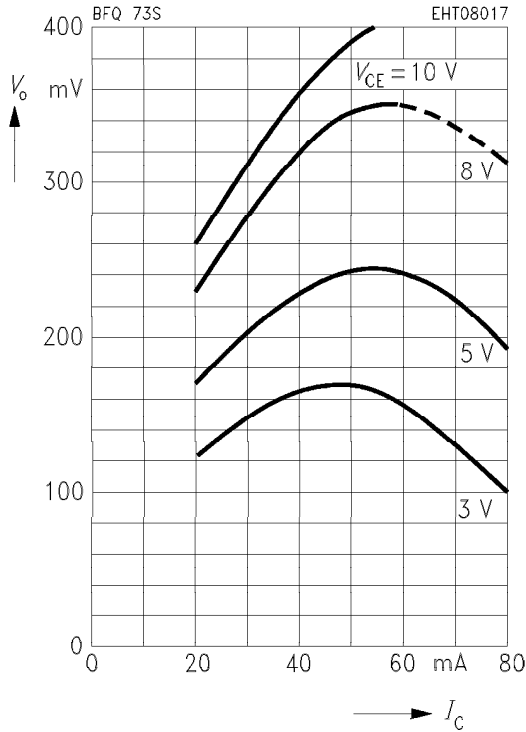

**Note:**

The transistor is driven by 2 adjacent signals  $f_1, f_2$  with equal output power levels  $P_o$  for each carrier.

The distance  $d_{IM}$  between  $P_o$  and the third order intermodulation products  $P_{IM}$  ( $2f_1 - f_2$  or  $2f_2 - f_1$ ) is:

$$d_{IM} = P_o - P_{IM}$$

where  $P_o = 10 \log (V_o^2 / (50 \Omega \cdot 1mW))$  (dBm)  
 and  $V_o =$  linear output voltage of each carrier.

The 3rd order intercept point  $IP_3$  will be found by extrapolation to the point where  $P_{IM}$  would be identical to  $P_o$ :

$$IP_3 (\text{output}) = P_o + d_{IM}/2.$$

Linear output voltages for other  $d_{IM}$  (e.g. 50 dB) can be calculated thereby.

This datasheet has been downloaded from:

[www.DatasheetCatalog.com](http://www.DatasheetCatalog.com)

Datasheets for electronic components.



LittleDiode supplies new, hard to find or obsolete electronic components and semiconductors all over the world.

With over two million different components listed you are sure to find the part you need.

Feel free to visit us today at our online store:

[LittleDiode.com](http://LittleDiode.com)

Looking forward to providing you with the best possible service.