

NPN Silicon RF Transistor

BFQ 82

- For low-noise, high-gain amplifiers up to 2 GHz.
- Linear broadband applications at collector currents up to 40 mA.
- Hermetically sealed ceramic package.
- $f_T = 8$ GHz
 $F = 1.1$ dB at 800 MHz

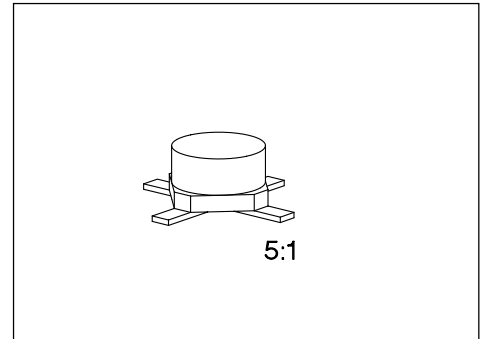

ESD: Electrostatic discharge sensitive device, observe handling precautions!

Type	Marking	Ordering Code (tape and reel)	Pin Configuration				Package ¹⁾
			1	2	3	4	
BFQ 82	82	Q62702-F1189	B	E	C	E	Cerrec-X

Maximum Ratings

Parameter	Symbol	Values	Unit
Collector-emitter voltage	V_{CE0}	12	V
Collector-emitter voltage, $V_{BE} = 0$	V_{CES}	20	
Collector-base voltage	V_{CB0}	20	
Emitter-base voltage	V_{EB0}	2	
Collector current	I_C	80	mA
Peak collector current, $f \geq 10$ MHz	I_{CM}	80	
Base current	I_B	10	
Peak base current, $f \geq 10$ MHz	I_{BM}	10	
Total power dissipation, $T_s \leq 95$ °C ³⁾	P_{tot}	500	mW
Junction temperature	T_j	175	°C
Ambient temperature range	T_A	- 65 ... + 175	
Storage temperature range	T_{stg}	- 65 ... + 175	

Thermal Resistance

Junction - ambient ²⁾	$R_{th JA}$	≤ 240	K/W
Junction - case ³⁾	$R_{th JS}$	≤ 160	

1) For detailed information see chapter Package Outlines.

2) Package mounted on alumina 15 mm × 16.7 mm × 0.7 mm.

3) T_s is measured on the collector lead at the soldering point to the pcb.

Electrical Characteristics

at $T_A = 25\text{ °C}$, unless otherwise specified.

Parameter	Symbol	Values			Unit
		min.	typ.	max.	

DC Characteristics

Collector-emitter breakdown voltage $I_C = 1\text{ mA}, I_B = 0$	$V_{(BR)CE0}$	12	–	–	V
Collector-emitter cutoff current $V_{CE} = 20\text{ V}, V_{BE} = 0$	I_{CES}	–	–	100	μA
Collector-base cutoff current $V_{CB} = 10\text{ V}, I_E = 0$ $V_{CB} = 10\text{ V}, I_E = 0, T_A = 125\text{ °C}$	I_{CBO}	– –	– –	0.05 5	
Emitter-base cutoff current $V_{EB} = 1\text{ V}, I_C = 0$	I_{EBO}	–	–	1	
DC current gain $I_C = 5\text{ mA}, V_{CE} = 8\text{ V}$ $I_C = 30\text{ mA}, V_{CE} = 8\text{ V}$	h_{FE}	– 50	110 120	– 250	–

Electrical Characteristics

at $T_A = 25\text{ °C}$, unless otherwise specified.

Parameter	Symbol	Values			Unit
		min.	typ.	max.	

AC Characteristics

Transition frequency $I_C = 5\text{ mA}$, $V_{CE} = 8\text{ V}$, $f = 500\text{ MHz}$ $I_C = 30\text{ mA}$, $V_{CE} = 8\text{ V}$, $f = 500\text{ MHz}$	f_t	–	3.6 8	–	GHz
Collector-base capacitance $V_{CB} = 10\text{ V}$, $V_{BE} = v_{be} = 0$, $f = 1\text{ MHz}$	C_{cb}	–	0.62	–	pF
Collector-emitter capacitance $V_{CE} = 10\text{ V}$, $V_{BE} = v_{be} = 0$, $f = 1\text{ MHz}$	C_{ce}	–	0.4	–	
Input capacitance $V_{EB} = 0.5\text{ V}$, $I_C = i_c = 0$, $f = 1\text{ MHz}$	C_{ibo}	–	2.5	–	
Output capacitance $V_{CE} = 10\text{ V}$, $V_{BE} = v_{be} = 0$, $f = 1\text{ MHz}$	C_{obs}	–	1.0	–	
Noise figure $I_C = 5\text{ mA}$, $V_{CE} = 8\text{ V}$, $f = 10\text{ MHz}$, $Z_S = 75\text{ }\Omega$ $I_C = 30\text{ mA}$, $V_{CE} = 8\text{ V}$, $f = 800\text{ MHz}$, $Z_S = Z_{Sopt}$ $I_C = 10\text{ mA}$, $V_{CE} = 8\text{ V}$, $f = 2\text{ GHz}$, $Z_S = Z_{Sopt}$	F	–	0.7 1.6 2.3	–	dB
Power gain $I_C = 30\text{ mA}$, $V_{CE} = 8\text{ V}$, $f = 1\text{ GHz}$, $Z_0 = 50\text{ }\Omega$ $I_C = 30\text{ mA}$, $V_{CE} = 8\text{ V}$, $f = 2\text{ GHz}$, $Z_0 = 50\text{ }\Omega$	$G_{ma}^{1)}$	–	17 11	–	
Transducer gain $I_C = 30\text{ mA}$, $V_{CE} = 8\text{ V}$, $f = 1\text{ GHz}$, $Z_0 = 50\text{ }\Omega$	$ S_{21e} ^2$	–	13.5	–	
Linear output voltage two-tone intermodulation test $I_C = 40\text{ mA}$, $V_{CE} = 8\text{ V}$, $d_{IM} = 60\text{ dB}$, $f_1 = 806\text{ MHz}$, $f_2 = 810\text{ MHz}$, $Z_S = Z_L = 50\text{ }\Omega$	$V_{o1} = V_{o2}$	–	280	–	mV
Third order intercept point $I_C = 40\text{ mA}$, $V_{CE} = 8\text{ V}$, $f = 800\text{ MHz}$	IP_3	–	32	–	dBm

1) $\left| \frac{S_{21e}}{S_{12e}} \right| (k - \sqrt{k^2 - 1})$

Total power dissipation $P_{tot} = f(T_A^*; T_S)$

* Package mounted on alumina

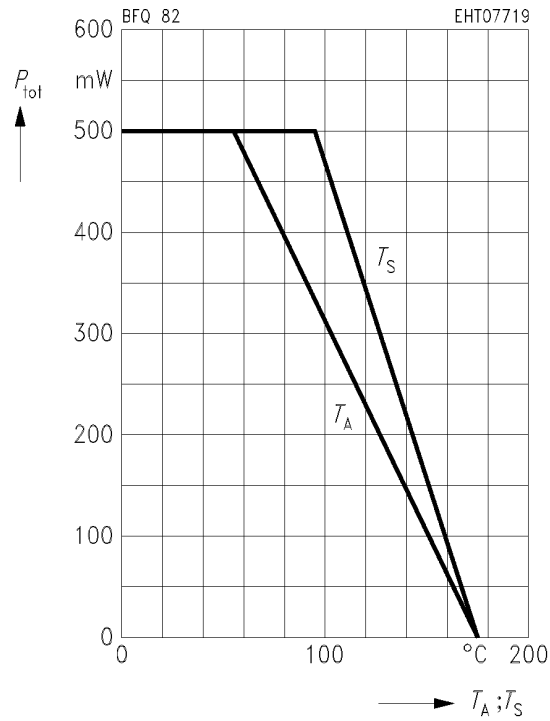

Transition frequency $f_T = f(I_C)$

$f = 500$ MHz

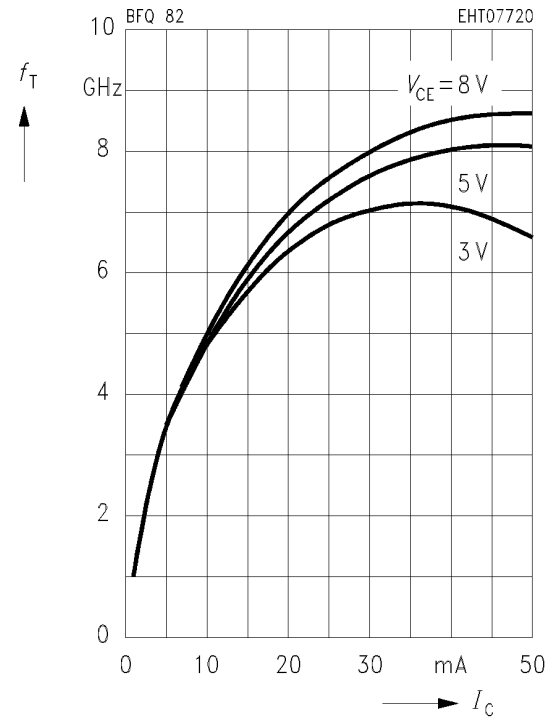

Collector-base capacitance $C_{cb} = f(V_{CB})$

$V_{BE} = v_{be} = 0, f = 1$ MHz

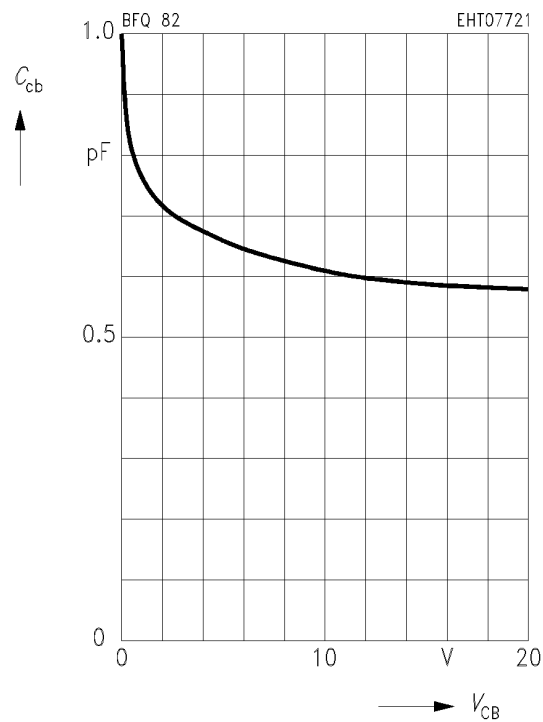

Common Emitter Noise Parameters

f	F_{min}	$G_p(F_{min})$	Γ_{opt}		R_N	N	$F_{50\Omega}$	$G_p(F_{50\Omega})$
GHz	dB	dB	MAG	ANG	Ω	-	dB	dB

$I_C = 10 \text{ mA}, V_{CE} = 8 \text{ V}, Z_0 = 50 \Omega$

0.01	1	-	(Z _s = 75 Ω)		-	-	1.05	-
0.8	1.15	15.7	-	-	-	-	1.35	14.7
2.0	2.3	9.5	-	-	-	-	2.8	7.5

$I_C = 30 \text{ mA}, V_{CE} = 8 \text{ V}, Z_0 = 50 \Omega$

0.01	1.65	-	(Z _s = 50 Ω)		-	-	1.65	-
0.8	1.6	17	-	-	-	-	1.95	15.8
2.0	2.6	10	-	-	-	-	3.3	8

Noise figure $F = f(I_C)$

$V_{CE} = 8 \text{ V}, f = 10 \text{ MHz}$

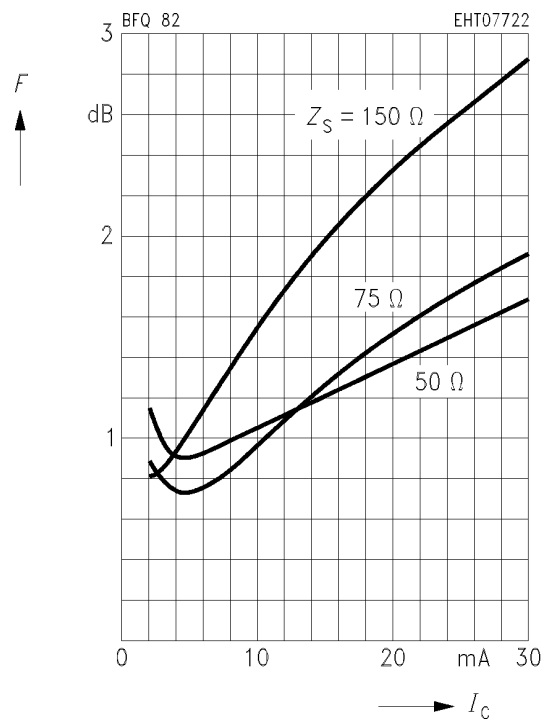

Noise figure $F = f(I_c)$

Power gain $G = f(I_c)$

$V_{CE} = 8 \text{ V}, f = 800 \text{ MHz}, Z_{Lopt}(G)$

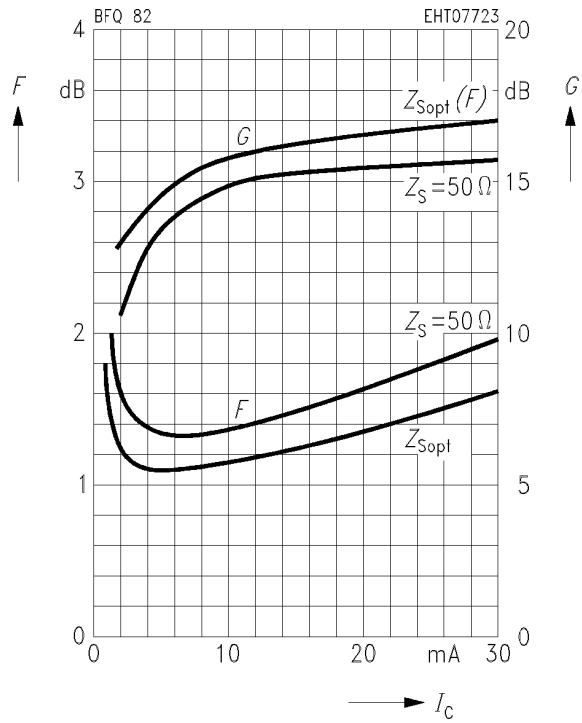

Noise figure $F = f(I_c)$

Power gain $G = f(I_c)$

$V_{CE} = 8 \text{ V}, f = 2 \text{ GHz}, Z_{Lopt}(G)$

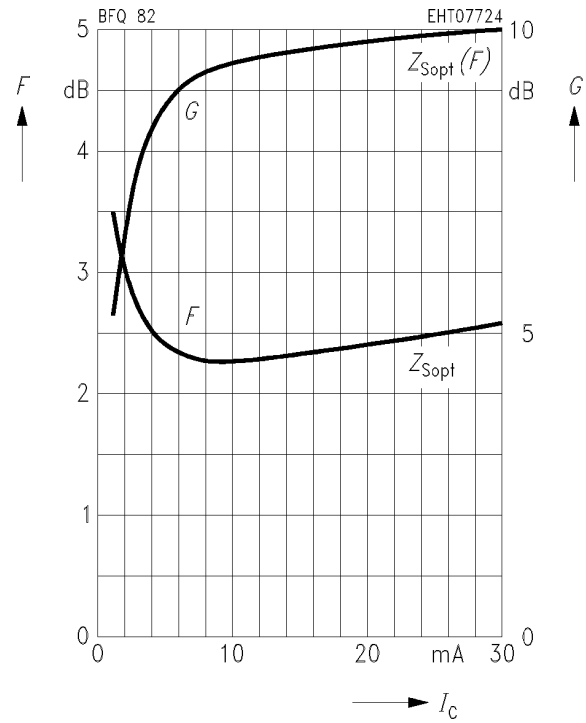

Common Emitter Power Gain

Power gain $G_{ms}, |S_{21e}|^2 = f(I_C)$

$V_{CE} = 8 \text{ V}, f = 200 \text{ MHz}, Z_0 = 50 \Omega$

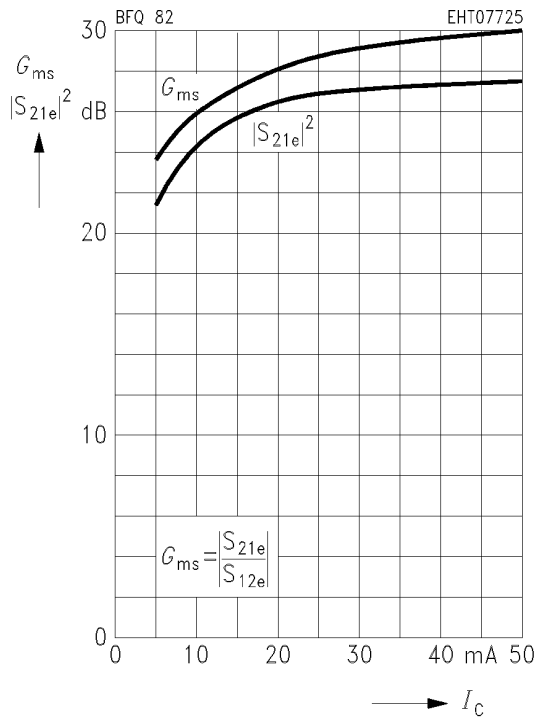

Power gain $G_{ms}, |S_{21e}|^2 = f(I_C)$

$V_{CE} = 8 \text{ V}, f = 500 \text{ MHz}, Z_0 = 50 \Omega$

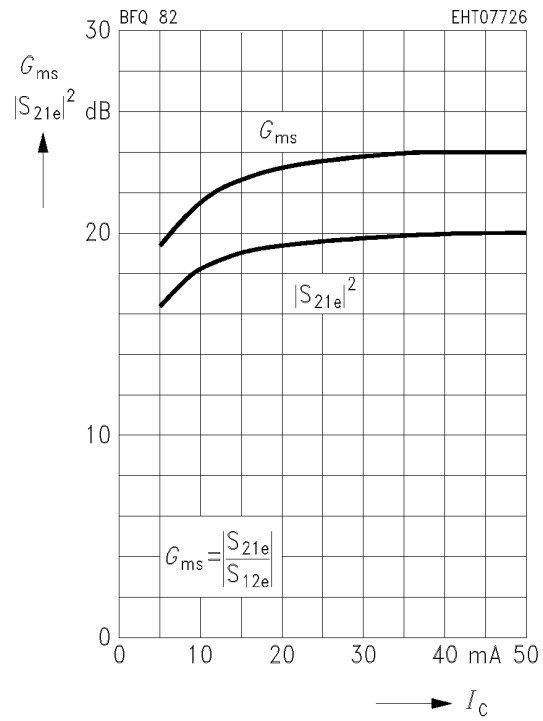

Power gain $G_{ma}, G_{ms}, |S_{21e}|^2 = f(I_C)$

$V_{CE} = 8 \text{ V}, f = 1 \text{ GHz}, Z_0 = 50 \Omega$

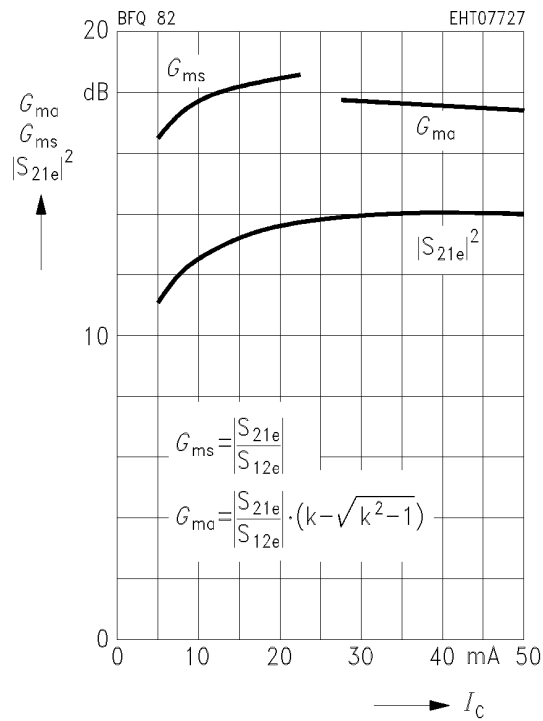

Power gain $G_{ma}, |S_{21e}|^2 = f(I_C)$

$V_{CE} = 8 \text{ V}, f = 2 \text{ GHz}, Z_0 = 50 \Omega$

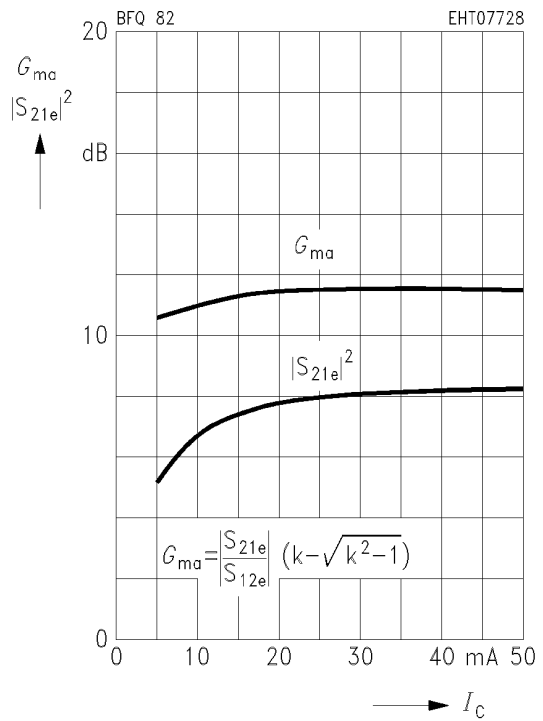

Power gain $G_{ma}, G_{ms}, |S_{21e}|^2 = f(f)$
 $I_C = 5 \text{ mA}, V_{CE} = 8 \text{ V}, Z_0 = 50 \Omega$

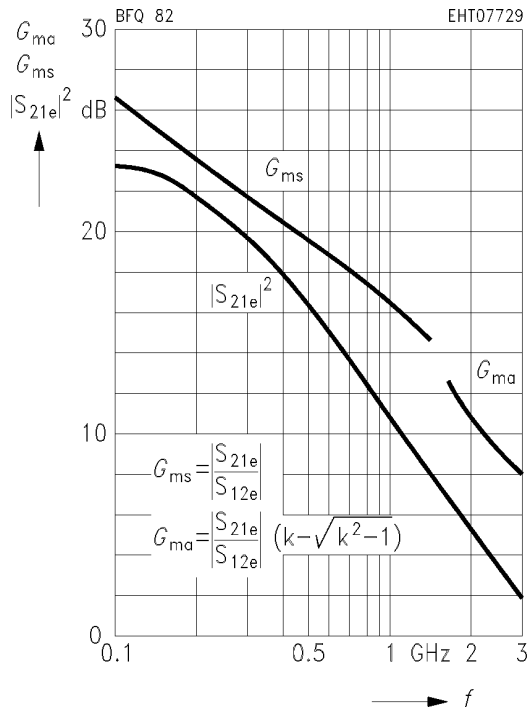

Power gain $G_{ma}, G_{ms}, |S_{21e}|^2 = f(f)$
 $I_C = 10 \text{ mA}, V_{CE} = 8 \text{ V}, Z_0 = 50 \Omega$

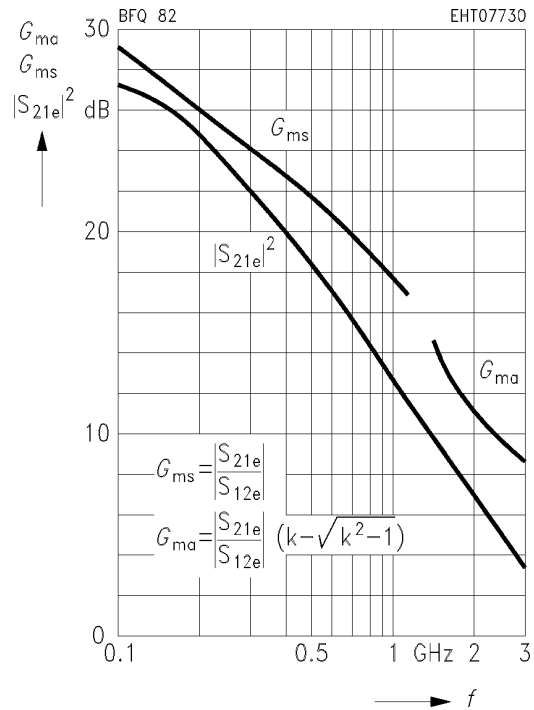

Power gain $G_{ma}, G_{ms}, |S_{21e}|^2 = f(f)$
 $I_C = 30 \text{ mA}, V_{CE} = 8 \text{ V}, Z_0 = 50 \Omega$

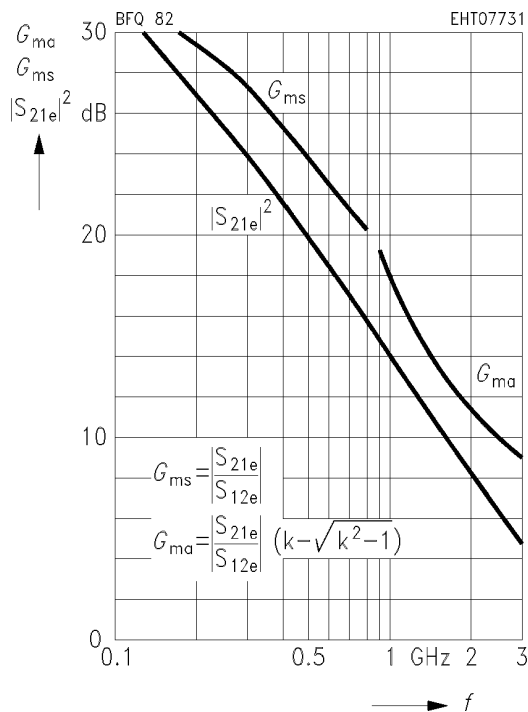

Power gain $G_{ma}, G_{ms}, |S_{21e}|^2 = f(f)$
 $I_C = 50 \text{ mA}, V_{CE} = 8 \text{ V}, Z_0 = 50 \Omega$

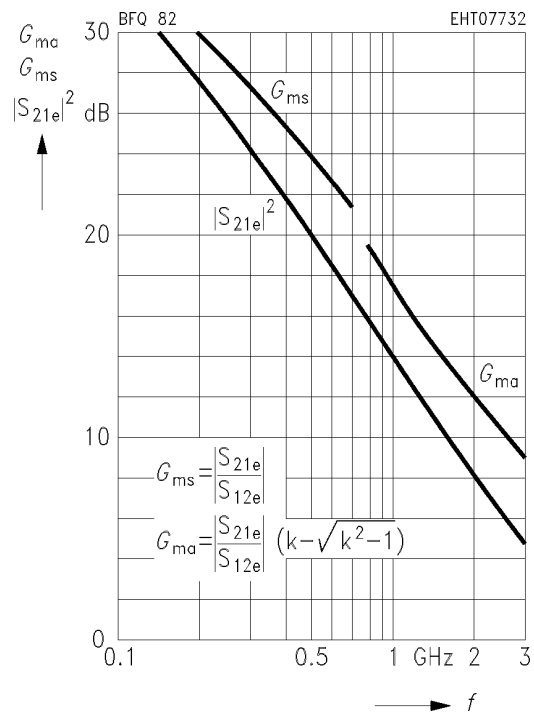

Common Emitter S Parameters

<i>f</i>	<i>S</i> ₁₁		<i>S</i> ₂₁		<i>S</i> ₁₂		<i>S</i> ₂₂	
	MAG	ANG	MAG	ANG	MAG	ANG	MAG	ANG

*I*_C = 10 mA, *V*_{CE} = 3 V, *Z*₀ = 50 Ω

0.10	0.549	- 117.0	34.54	127.9	0.020	53.4	0.627	- 55.5
0.15	0.598	- 136.2	26.39	116.1	0.023	48.5	0.486	- 69.3
0.20	0.620	- 147.9	20.98	108.4	0.026	47.7	0.394	- 79.1
0.25	0.633	- 155.9	17.29	103.0	0.028	47.7	0.333	- 86.8
0.30	0.641	- 161.4	14.67	98.9	0.031	48.7	0.288	- 93.1
0.40	0.651	- 169.7	11.21	92.7	0.035	51.2	0.234	- 103.1
0.50	0.655	- 175.5	9.06	87.8	0.040	53.3	0.203	- 110.8
0.60	0.657	- 180.0	7.60	83.8	0.045	54.9	0.183	- 117.4
0.70	0.661	175.8	6.53	80.1	0.051	56.1	0.170	- 123.1
0.80	0.665	172.6	5.74	76.6	0.056	56.9	0.161	- 127.8
0.90	0.671	169.6	5.09	73.6	0.061	57.2	0.154	- 132.8
1.00	0.673	166.7	4.58	70.6	0.067	57.5	0.149	- 136.9
1.20	0.680	161.2	3.82	65.6	0.078	57.4	0.142	- 145.3
1.40	0.679	155.8	3.31	60.6	0.089	56.7	0.139	- 150.8
1.50	0.680	153.4	3.10	58.1	0.095	55.8	0.140	- 152.4
1.60	0.683	151.1	2.92	55.3	0.101	55.1	0.141	- 154.4
1.80	0.688	146.7	2.59	49.9	0.112	53.1	0.146	- 159.0
2.00	0.701	143.0	2.33	45.3	0.122	51.3	0.151	- 165.6
2.50	0.729	133.3	1.90	35.3	0.150	46.8	0.175	- 178.4
3.00	0.735	122.1	1.62	23.5	0.177	40.6	0.199	174.5

*I*_C = 30 mA, *V*_{CE} = 3 V, *Z*₀ = 50 Ω

0.10	0.664	- 71.4	22.66	142.7	0.029	59.7	0.815	- 33.7
0.15	0.666	- 94.9	19.20	130.2	0.038	50.7	0.694	- 44.5
0.20	0.666	- 112.0	16.25	121.0	0.043	44.9	0.593	- 52.4
0.25	0.664	- 124.8	13.90	113.9	0.046	40.9	0.514	- 58.2
0.30	0.666	- 134.3	12.07	108.4	0.049	38.5	0.452	- 62.5
0.40	0.670	- 148.4	9.48	99.9	0.052	36.1	0.366	- 68.6
0.50	0.670	- 158.0	7.78	93.6	0.056	35.7	0.313	- 72.8
0.60	0.671	- 165.3	6.57	88.4	0.058	35.9	0.275	- 76.1
0.70	0.675	- 171.5	5.67	83.8	0.061	36.6	0.249	- 79.0
0.80	0.679	- 176.4	5.01	79.6	0.064	37.4	0.231	- 81.3
0.90	0.684	179.2	4.45	76.0	0.067	38.2	0.214	- 83.7
1.00	0.686	175.4	4.01	72.5	0.070	39.5	0.203	- 85.8
1.20	0.693	168.4	3.35	66.5	0.077	41.3	0.185	- 90.5
1.40	0.691	162.0	2.90	60.9	0.084	42.8	0.177	- 94.9
1.50	0.692	159.3	2.72	58.1	0.089	43.0	0.177	- 97.2
1.60	0.697	156.5	2.56	55.1	0.093	43.3	0.177	- 99.6
1.80	0.703	151.4	2.28	49.3	0.101	43.3	0.177	- 105.1
2.00	0.713	147.0	2.05	44.2	0.109	43.3	0.176	- 112.0
2.50	0.741	136.2	1.67	33.1	0.133	42.5	0.188	- 130.5
3.00	0.748	124.5	1.42	20.7	0.157	39.0	0.215	- 144.6

Common Emitter S Parameters (continued)

<i>f</i>	<i>S</i> ₁₁		<i>S</i> ₂₁		<i>S</i> ₁₂		<i>S</i> ₂₂	
	MAG	ANG	MAG	ANG	MAG	ANG	MAG	ANG
0.10	0.783	- 48.9	14.66	152.0	0.033	66.4	0.904	- 21.5
0.15	0.763	- 68.9	13.27	140.7	0.045	57.1	0.827	- 29.7
0.20	0.745	- 85.7	11.86	131.3	0.054	49.8	0.748	- 36.1
0.25	0.732	- 99.4	10.58	123.5	0.060	44.0	0.677	- 41.1
0.30	0.722	- 110.7	9.45	117.2	0.065	39.6	0.616	- 44.8
0.40	0.708	- 128.3	7.69	107.1	0.070	33.5	0.525	- 50.0
0.50	0.701	- 141.0	6.43	99.4	0.074	29.7	0.462	- 53.2
0.60	0.697	- 151.0	5.50	93.0	0.076	27.3	0.420	- 55.7
0.70	0.698	- 158.9	4.80	87.4	0.078	25.9	0.388	- 57.6
0.80	0.700	- 165.5	4.24	82.6	0.079	24.9	0.366	- 59.2
0.90	0.703	- 171.2	3.81	78.1	0.080	24.6	0.348	- 61.0
1.00	0.704	- 176.4	3.43	74.1	0.081	24.6	0.333	- 62.8
1.20	0.710	174.6	2.88	66.9	0.082	25.4	0.314	- 66.2
1.40	0.713	166.9	2.49	60.5	0.085	27.0	0.304	- 69.9
1.50	0.709	163.8	2.34	57.4	0.087	28.0	0.302	- 72.3
1.60	0.711	160.3	2.20	54.1	0.089	28.8	0.301	- 74.6
1.80	0.719	154.2	1.97	47.7	0.093	30.4	0.300	- 79.8
2.00	0.727	148.8	1.77	42.0	0.097	31.9	0.296	- 85.6
2.50	0.755	137.2	1.43	30.0	0.114	36.1	0.300	- 102.2
3.00	0.758	124.0	1.22	16.2	0.135	36.2	0.322	- 118.6

$I_C = 5 \text{ mA}, V_{CE} = 5 \text{ V}, Z_0 = 50 \Omega$

$S_{11}, S_{22} = f(f)$

$I_C = 5 \text{ mA}, V_{CE} = 5 \text{ V}, Z_0 = 50 \Omega$

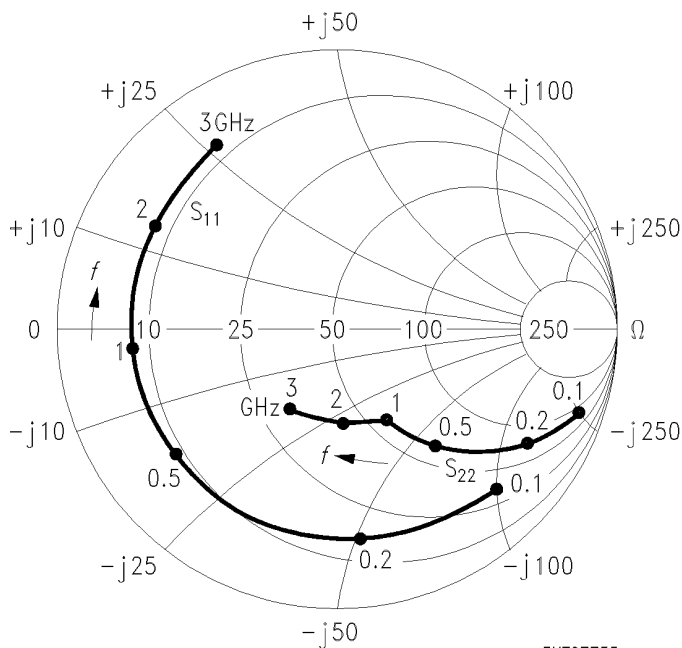

EHT07733

$S_{12}, S_{21} = f(f)$

$I_C = 5 \text{ mA}, V_{CE} = 5 \text{ V}, Z_0 = 50 \Omega$

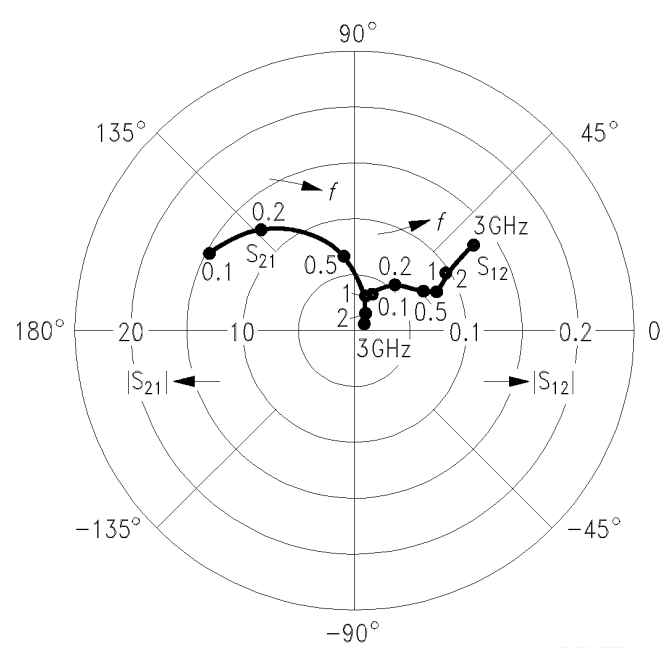

EHT07734

Common Emitter S Parameters (continued)

<i>f</i>	<i>S</i> ₁₁		<i>S</i> ₂₁		<i>S</i> ₁₂		<i>S</i> ₂₂	
	MAG	ANG	MAG	ANG	MAG	ANG	MAG	ANG
GHz								
<i>I</i> _C = 10 mA, <i>V</i> _{CE} = 5 V, <i>Z</i> ₀ = 50 Ω								
0.10	0.670	- 68.9	23.03	143.5	0.028	60.6	0.822	- 32.5
0.15	0.664	- 92.4	19.59	131.0	0.037	51.4	0.705	- 43.2
0.20	0.661	- 109.9	16.65	121.7	0.042	45.5	0.604	- 51.1
0.25	0.660	- 122.6	14.30	114.5	0.045	41.6	0.525	- 56.7
0.30	0.660	- 132.6	12.45	108.9	0.048	39.1	0.462	- 60.9
0.40	0.658	- 147.1	9.79	100.3	0.052	36.6	0.376	- 66.9
0.50	0.660	- 157.1	8.04	93.9	0.055	35.8	0.319	- 70.8
0.60	0.662	- 164.9	6.80	88.6	0.058	36.1	0.283	- 73.9
0.70	0.664	- 171.0	5.88	83.9	0.061	36.8	0.256	- 76.4
0.80	0.669	- 176.3	5.17	79.8	0.064	37.4	0.237	- 78.5
0.90	0.672	- 179.2	4.62	76.0	0.067	38.4	0.222	- 80.8
1.00	0.675	- 175.0	4.16	72.5	0.070	39.2	0.209	- 83.1
1.20	0.682	- 167.4	3.48	66.2	0.076	40.8	0.191	- 87.2
1.40	0.687	- 160.9	3.00	60.5	0.084	41.9	0.182	- 91.0
1.50	0.684	- 158.2	2.82	57.7	0.088	42.5	0.181	- 93.2
1.60	0.684	- 155.1	2.65	54.7	0.092	42.6	0.180	- 95.5
1.80	0.693	- 149.8	2.37	48.8	0.101	42.6	0.181	- 101.1
2.00	0.701	- 144.9	2.13	43.6	0.108	42.2	0.179	- 107.6
2.50	0.732	- 134.5	1.73	32.6	0.132	41.4	0.188	- 124.6
3.00	0.735	- 122.0	1.47	19.2	0.156	37.4	0.215	- 139.6

*S*₁₁, *S*₂₂ = *f* (*f*)

*I*_C = 10 mA, *V*_{CE} = 5 V, *Z*₀ = 50 Ω

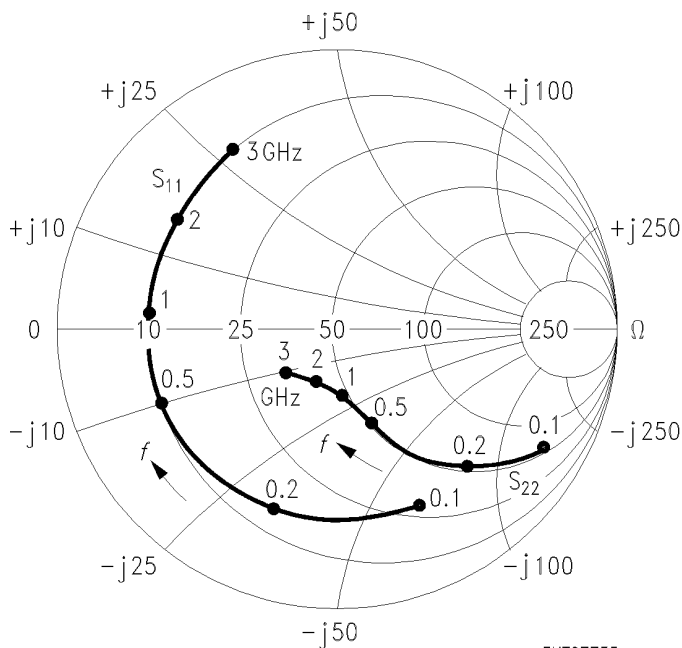

EHT07735

*S*₁₂, *S*₂₁ = *f* (*f*)

*I*_C = 10 mA, *V*_{CE} = 5 V, *Z*₀ = 50 Ω

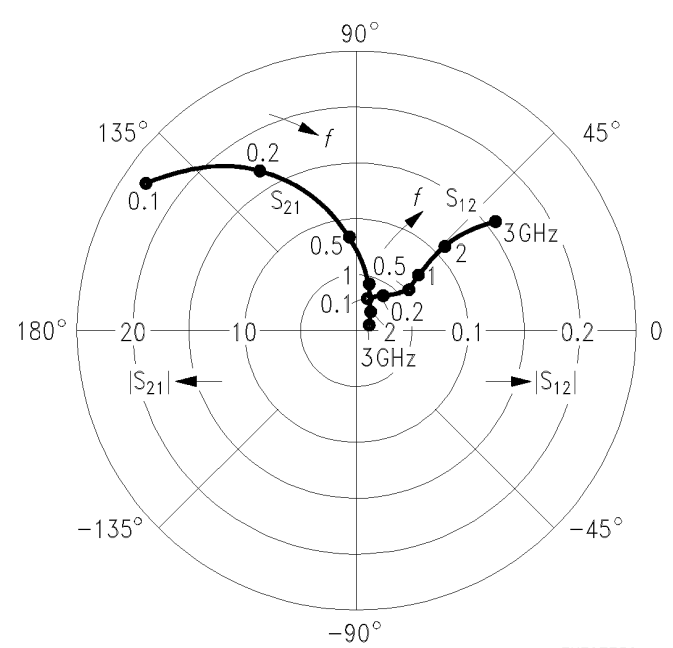

EHT07736

Common Emitter S Parameters (continued)

<i>f</i>	<i>S</i> ₁₁		<i>S</i> ₂₁		<i>S</i> ₁₂		<i>S</i> ₂₂	
	MAG	ANG	MAG	ANG	MAG	ANG	MAG	ANG
<i>I</i> _C = 30 mA, <i>V</i> _{CE} = 5 V, <i>Z</i> ₀ = 50 Ω								
0.10	0.545	-111.4	35.72	129.0	0.020	54.2	0.642	-53.6
0.15	0.584	-132.2	27.43	117.1	0.023	49.3	0.501	-67.2
0.20	0.605	-145.0	21.91	109.2	0.026	47.9	0.407	-76.8
0.25	0.617	-153.2	18.11	103.7	0.029	47.9	0.342	-84.3
0.30	0.625	-159.3	15.39	99.5	0.031	48.7	0.297	-90.3
0.40	0.631	-168.3	11.77	93.0	0.035	50.9	0.239	-100.0
0.50	0.637	-174.7	9.54	88.2	0.040	52.8	0.205	-107.7
0.60	0.641	-179.7	7.99	84.0	0.046	54.4	0.184	-113.8
0.70	0.644	176.4	6.87	80.2	0.051	55.6	0.171	-119.2
0.80	0.648	172.8	6.03	76.8	0.056	56.2	0.161	-123.9
0.90	0.652	169.5	5.36	73.6	0.061	56.4	0.154	-128.3
1.00	0.657	166.4	4.82	70.7	0.067	56.6	0.148	-133.2
1.20	0.665	160.2	4.03	65.4	0.078	56.3	0.140	-140.9
1.40	0.671	154.6	3.47	60.3	0.089	55.5	0.134	-146.8
1.50	0.665	152.3	3.26	57.8	0.095	54.8	0.135	-148.8
1.60	0.666	149.6	3.06	55.0	0.101	54.0	0.136	-150.7
1.80	0.674	145.0	2.73	49.7	0.112	51.9	0.141	-155.2
2.00	0.682	141.1	2.45	44.8	0.122	49.9	0.146	-161.6
2.50	0.713	131.4	1.99	34.7	0.150	45.3	0.164	-174.4
3.00	0.715	119.8	1.69	22.1	0.175	38.8	0.191	178.0

*S*₁₁, *S*₂₂ = *f*(*f*)

*I*_C = 30 mA, *V*_{CE} = 5 V, *Z*₀ = 50 Ω

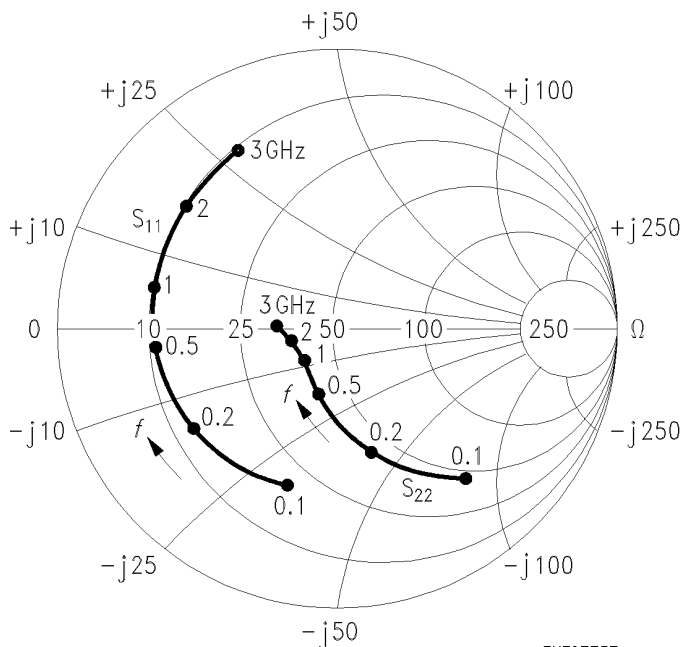

EHT07737

*S*₁₂, *S*₂₁ = *f*(*f*)

*I*_C = 30 mA, *V*_{CE} = 5 V, *Z*₀ = 50 Ω

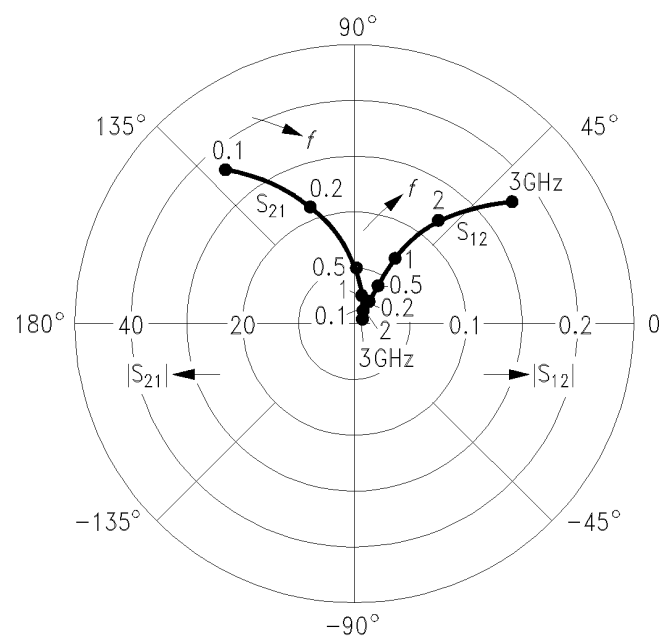

EHT07738

Common Emitter S Parameters (continued)

<i>f</i>	<i>S</i> ₁₁		<i>S</i> ₂₁		<i>S</i> ₁₂		<i>S</i> ₂₂	
	MAG	ANG	MAG	ANG	MAG	ANG	MAG	ANG
GHz								
<i>I</i> _C = 50 mA, <i>V</i> _{CE} = 5 V, <i>Z</i> ₀ = 50 Ω								
0.10	0.541	-128.9	38.90	123.5	0.016	53.8	0.560	-62.3
0.15	0.587	-145.8	28.86	112.3	0.020	51.3	0.425	-76.6
0.20	0.609	-155.7	22.67	105.3	0.022	51.6	0.344	-87.0
0.25	0.622	-162.0	18.56	100.5	0.025	53.0	0.291	-95.2
0.30	0.629	-166.9	15.69	96.7	0.027	54.7	0.255	-101.9
0.40	0.635	-173.9	11.94	90.9	0.032	57.5	0.212	-112.8
0.50	0.640	-179.2	9.64	86.4	0.038	59.3	0.186	-121.3
0.60	0.645	176.3	8.07	82.5	0.044	60.4	0.172	-127.8
0.70	0.649	173.1	6.93	79.0	0.050	61.1	0.164	-133.4
0.80	0.651	169.8	6.08	75.8	0.055	61.2	0.157	-138.2
0.90	0.656	167.0	5.41	72.7	0.061	61.1	0.153	-142.6
1.00	0.660	164.0	4.85	69.9	0.067	60.8	0.151	-147.3
1.20	0.668	158.5	4.05	64.7	0.079	59.9	0.147	-154.8
1.40	0.673	153.1	3.49	59.9	0.091	58.5	0.143	-160.5
1.50	0.668	150.9	3.28	57.3	0.097	57.6	0.144	-162.2
1.60	0.671	148.3	3.09	54.7	0.103	56.5	0.145	-163.8
1.80	0.676	143.8	2.75	49.4	0.115	53.9	0.150	-167.6
2.00	0.685	140.1	2.46	44.6	0.125	51.5	0.157	-173.2
2.50	0.716	130.6	2.00	34.7	0.153	46.4	0.177	175.7
3.00	0.717	119.1	1.70	22.2	0.179	39.2	0.202	169.6

*S*₁₁, *S*₂₂ = *f*(*f*)

*I*_C = 50 mA, *V*_{CE} = 5 V, *Z*₀ = 50 Ω

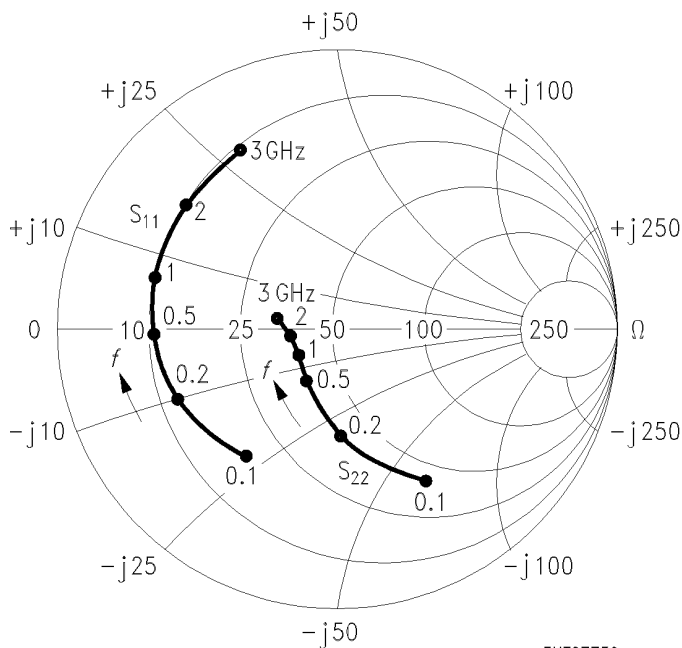

*S*₁₂, *S*₂₁ = *f*(*f*)

*I*_C = 50 mA, *V*_{CE} = 5 V, *Z*₀ = 50 Ω

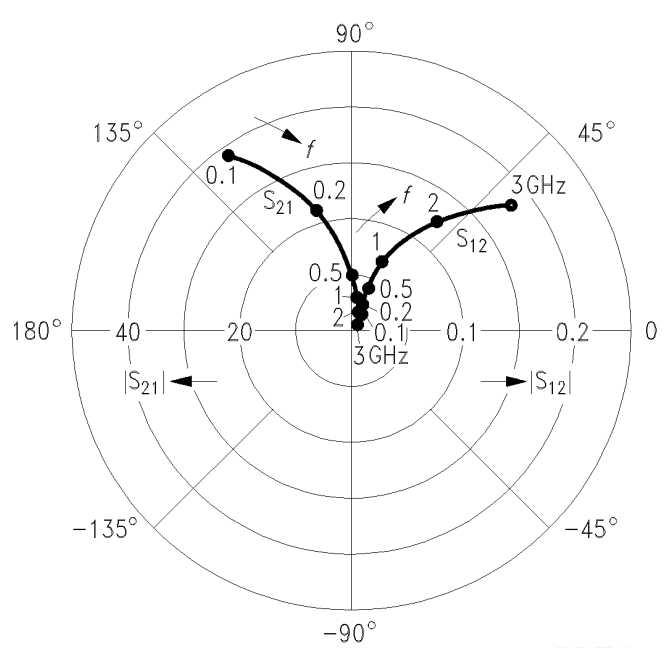

Common Emitter S Parameters (continued)

<i>f</i>	<i>S</i> ₁₁		<i>S</i> ₂₁		<i>S</i> ₁₂		<i>S</i> ₂₂	
	MAG	ANG	MAG	ANG	MAG	ANG	MAG	ANG
0.10	0.792	- 47.3	14.67	152.6	0.033	66.9	0.908	- 20.9
0.15	0.771	- 67.0	13.33	141.4	0.044	57.6	0.833	- 28.9
0.20	0.751	- 83.6	11.96	132.1	0.053	50.5	0.756	- 35.2
0.25	0.736	- 97.1	10.69	124.4	0.059	44.8	0.686	- 40.1
0.30	0.724	- 108.5	9.57	118.0	0.064	40.3	0.626	- 43.9
0.40	0.707	- 126.2	7.82	107.8	0.070	34.1	0.535	- 49.0
0.50	0.699	- 139.2	6.55	100.1	0.073	30.1	0.472	- 52.3
0.60	0.695	- 149.4	5.61	93.6	0.076	27.6	0.428	- 54.7
0.70	0.695	- 157.5	4.90	88.1	0.077	26.3	0.397	- 56.6
0.80	0.696	- 164.3	4.33	83.2	0.079	25.1	0.374	- 58.2
0.90	0.698	- 170.0	3.89	78.7	0.080	24.9	0.355	- 59.9
1.00	0.699	- 175.4	3.51	74.6	0.080	24.8	0.340	- 61.6
1.20	0.704	175.4	2.95	67.4	0.082	25.5	0.320	- 64.9
1.40	0.708	167.6	2.54	61.0	0.085	27.0	0.310	- 68.6
1.50	0.706	164.5	2.39	58.0	0.086	27.9	0.308	- 70.9
1.60	0.705	160.9	2.25	54.6	0.088	28.8	0.307	- 73.1
1.80	0.715	154.8	2.01	48.3	0.093	30.3	0.305	- 78.3
2.00	0.723	149.3	1.81	42.6	0.096	31.9	0.301	- 83.9
2.50	0.750	137.4	1.47	30.6	0.113	35.9	0.303	- 100.1
3.00	0.755	124.3	1.25	16.8	0.134	36.1	0.323	- 116.5

*I*_C = 5 mA, *V*_{CE} = 8 V, *Z*₀ = 50 Ω

*S*₁₁, *S*₂₂ = *f* (*f*)

*I*_C = 5 mA, *V*_{CE} = 8 V, *Z*₀ = 50 Ω

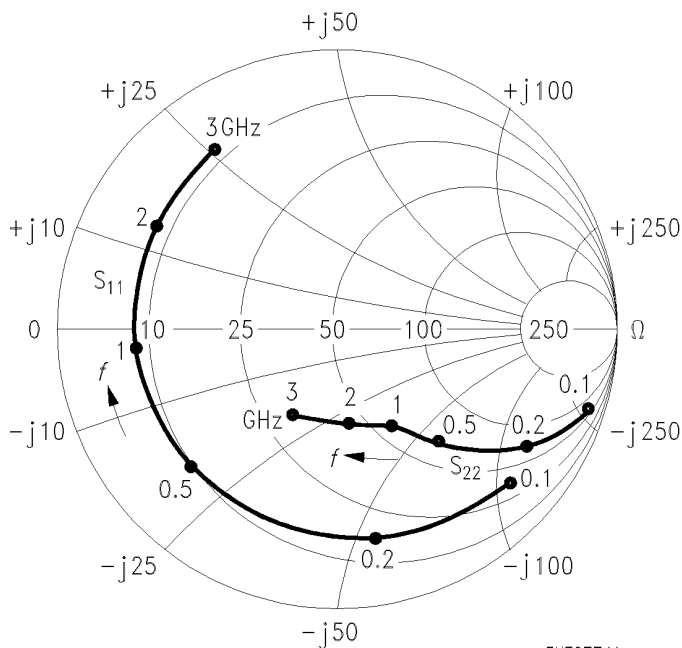

EHT07741

*S*₁₂, *S*₂₁ = *f* (*f*)

*I*_C = 5 mA, *V*_{CE} = 8 V, *Z*₀ = 50 Ω

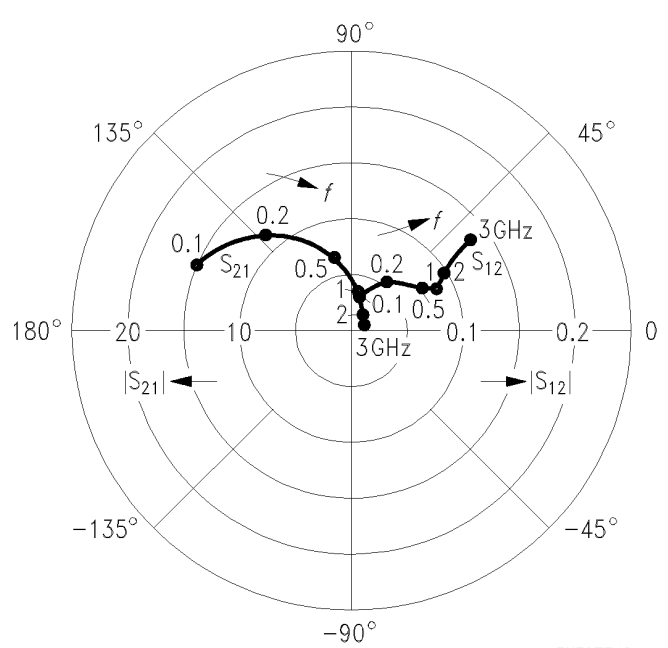

EHT07742

Common Emitter S Parameters (continued)

<i>f</i>	<i>S</i> ₁₁		<i>S</i> ₂₁		<i>S</i> ₁₂		<i>S</i> ₂₂	
	MAG	ANG	MAG	ANG	MAG	ANG	MAG	ANG

*I*_C = 10 mA, *V*_{CE} = 8 V, *Z*₀ = 50 Ω

0.10	0.686	- 65.8	23.05	144.4	0.028	61.2	0.829	- 31.5
0.15	0.673	- 89.1	19.74	132.0	0.036	52.4	0.715	- 42.0
0.20	0.665	- 106.6	16.85	122.6	0.042	46.2	0.616	- 49.8
0.25	0.661	- 119.6	14.51	115.5	0.045	42.1	0.537	- 55.4
0.30	0.659	- 129.8	12.67	109.8	0.048	39.5	0.474	- 59.6
0.40	0.654	- 144.7	10.00	101.1	0.052	36.8	0.386	- 65.5
0.50	0.654	- 155.3	8.22	94.6	0.055	35.9	0.328	- 69.4
0.60	0.656	- 163.2	6.95	89.2	0.058	35.9	0.291	- 72.4
0.70	0.659	- 169.5	6.02	84.5	0.061	36.6	0.264	- 74.9
0.80	0.661	- 175.1	5.30	80.3	0.064	37.1	0.243	- 76.9
0.90	0.666	- 179.6	4.74	76.5	0.067	38.0	0.227	- 79.1
1.00	0.668	176.1	4.26	73.0	0.070	38.8	0.213	- 81.4
1.20	0.674	168.4	3.56	66.7	0.077	40.4	0.196	- 85.1
1.40	0.680	161.7	3.07	61.0	0.084	41.5	0.185	- 88.8
1.50	0.677	158.9	2.88	58.2	0.088	42.0	0.184	- 91.0
1.60	0.676	155.7	2.72	55.3	0.092	42.2	0.183	- 93.2
1.80	0.687	150.4	2.42	49.4	0.100	42.1	0.183	- 98.7
2.00	0.693	145.5	2.18	44.1	0.108	41.8	0.180	- 105.0
2.50	0.724	134.9	1.77	33.1	0.131	41.1	0.187	- 122.0
3.00	0.726	122.3	1.51	19.8	0.154	37.2	0.212	- 137.2

*S*₁₁, *S*₂₂ = *f* (*f*)

*I*_C = 10 mA, *V*_{CE} = 8 V, *Z*₀ = 50 Ω

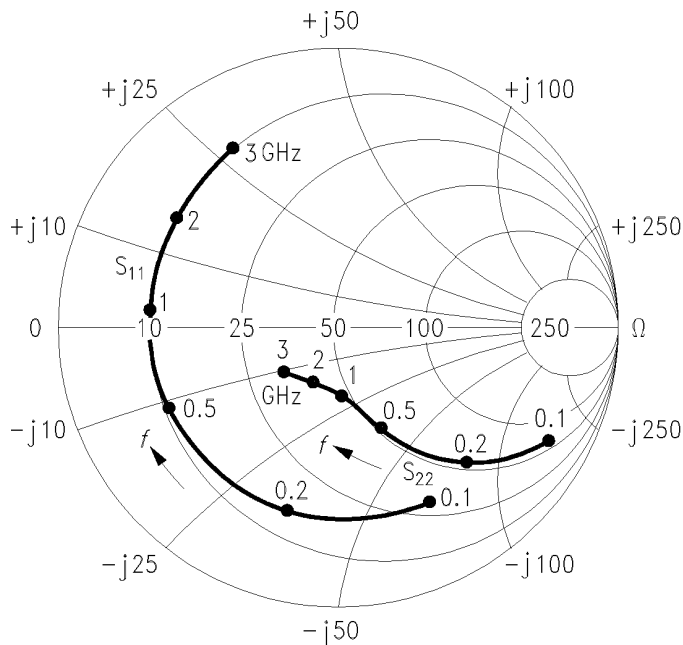

EHT07743

*S*₁₂, *S*₂₁ = *f* (*f*)

*I*_C = 10 mA, *V*_{CE} = 8 V, *Z*₀ = 50 Ω

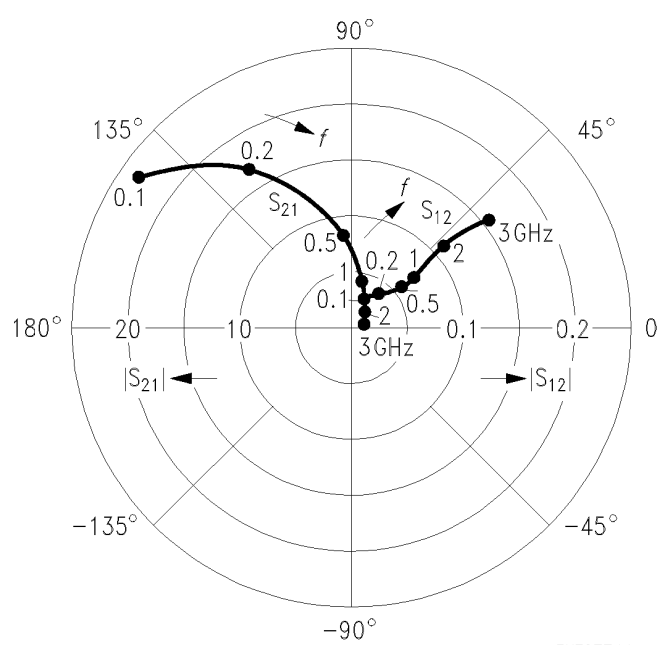

EHT07744

Common Emitter S Parameters (continued)

<i>f</i>	<i>S</i> ₁₁		<i>S</i> ₂₁		<i>S</i> ₁₂		<i>S</i> ₂₂	
	MAG	ANG	MAG	ANG	MAG	ANG	MAG	ANG
GHz								
<i>I</i> _C = 30 mA, <i>V</i> _{CE} = 8 V, <i>Z</i> ₀ = 50 Ω								
0.10	0.559	- 105.0	36.41	130.0	0.020	54.4	0.651	- 52.3
0.15	0.585	- 127.1	28.14	117.9	0.024	49.3	0.510	- 65.9
0.20	0.600	- 140.8	22.54	110.0	0.027	47.2	0.415	- 75.6
0.25	0.610	- 149.6	18.67	104.4	0.029	47.2	0.350	- 82.9
0.30	0.616	- 156.3	15.87	100.1	0.032	47.8	0.303	- 89.0
0.40	0.621	- 166.0	12.17	93.5	0.036	50.2	0.244	- 98.6
0.50	0.626	- 172.7	9.86	88.6	0.041	51.9	0.208	- 106.2
0.60	0.628	- 178.1	8.27	84.4	0.046	53.2	0.187	- 112.3
0.70	0.633	177.6	7.11	80.7	0.051	54.6	0.172	- 117.8
0.80	0.636	173.8	6.24	77.2	0.056	55.2	0.161	- 122.5
0.90	0.641	170.7	5.55	74.1	0.062	55.6	0.154	- 127.0
1.00	0.646	167.3	4.99	71.1	0.067	55.7	0.148	- 131.9
1.20	0.653	161.1	4.17	65.8	0.078	55.6	0.138	- 139.8
1.40	0.657	155.4	3.59	60.8	0.089	54.8	0.132	- 145.8
1.50	0.655	153.1	3.37	58.2	0.095	54.2	0.132	- 147.8
1.60	0.654	150.4	3.17	55.5	0.101	53.3	0.133	- 149.8
1.80	0.663	145.8	2.82	50.2	0.112	51.3	0.138	- 154.5
2.00	0.671	141.6	2.53	45.3	0.122	49.2	0.142	- 161.1
2.50	0.702	132.0	2.06	35.3	0.149	44.8	0.159	- 174.2
3.00	0.706	120.2	1.75	22.6	0.174	38.3	0.185	178.2

*S*₁₁, *S*₂₂ = *f* (*f*)

*I*_C = 30 mA, *V*_{CE} = 8 V, *Z*₀ = 50 Ω

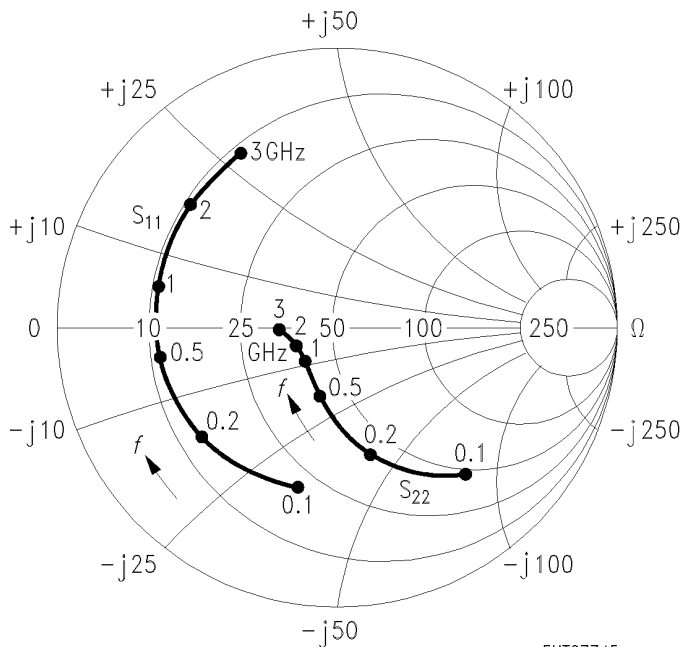

EHT07745

*S*₁₂, *S*₂₁ = *f* (*f*)

*I*_C = 30 mA, *V*_{CE} = 8 V, *Z*₀ = 50 Ω

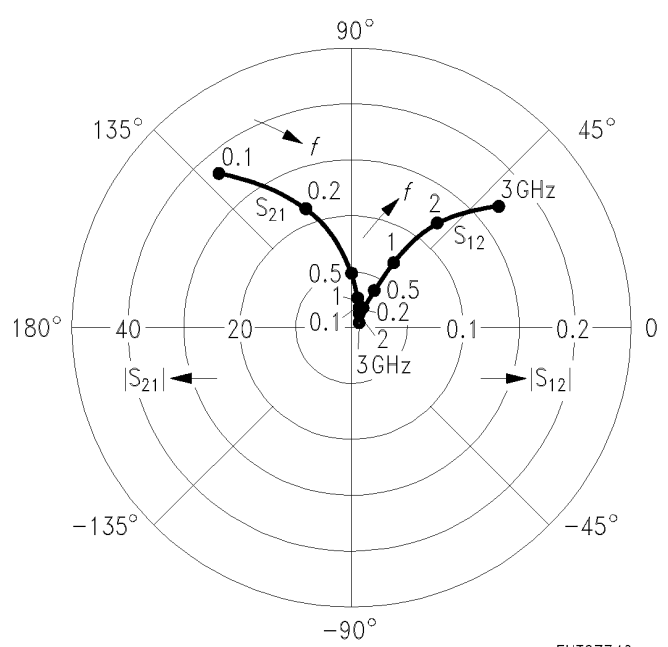

EHT07746

Common Emitter S Parameters (continued)

<i>f</i>	<i>S</i> ₁₁		<i>S</i> ₂₁		<i>S</i> ₁₂		<i>S</i> ₂₂	
	MAG	ANG	MAG	ANG	MAG	ANG	MAG	ANG
GHz								
<i>I</i> _C = 50 mA, <i>V</i> _{CE} = 8 V, <i>Z</i> ₀ = 50 Ω								
0.10	0.548	-120.2	39.95	124.5	0.017	53.4	0.569	-60.7
0.15	0.582	-139.4	29.82	113.2	0.020	50.0	0.434	-75.0
0.20	0.599	-150.9	23.47	106.0	0.023	50.2	0.351	-85.2
0.25	0.610	-158.0	19.26	101.1	0.026	51.5	0.296	-93.2
0.30	0.616	-163.4	16.29	97.3	0.028	53.1	0.259	-99.9
0.40	0.621	-171.5	12.41	91.4	0.033	55.7	0.213	-110.7
0.50	0.625	-177.3	10.01	86.9	0.039	57.7	0.186	-119.1
0.60	0.629	178.2	8.39	83.0	0.045	58.9	0.171	-125.6
0.70	0.632	174.6	7.20	79.4	0.050	59.7	0.162	-131.4
0.80	0.636	171.1	6.32	76.2	0.056	59.9	0.155	-136.2
0.90	0.640	168.1	5.62	73.1	0.062	59.9	0.151	-140.8
1.00	0.644	165.1	5.05	70.3	0.067	59.7	0.147	-145.6
1.20	0.652	159.2	4.21	65.2	0.079	58.9	0.142	-153.4
1.40	0.657	153.8	3.63	60.4	0.091	57.5	0.138	-159.4
1.50	0.653	151.6	3.41	57.8	0.097	56.6	0.138	-161.1
1.60	0.655	149.0	3.21	55.1	0.103	55.5	0.139	-162.8
1.80	0.663	144.5	2.85	49.9	0.115	53.0	0.145	-166.7
2.00	0.670	140.8	2.56	45.1	0.125	50.8	0.151	-172.7
2.50	0.700	131.2	2.08	35.3	0.153	45.6	0.169	176.0
3.00	0.704	119.6	1.77	22.7	0.178	38.6	0.193	169.8

*S*₁₁, *S*₂₂ = *f*(*f*)

*I*_C = 50 mA, *V*_{CE} = 8 V, *Z*₀ = 50 Ω

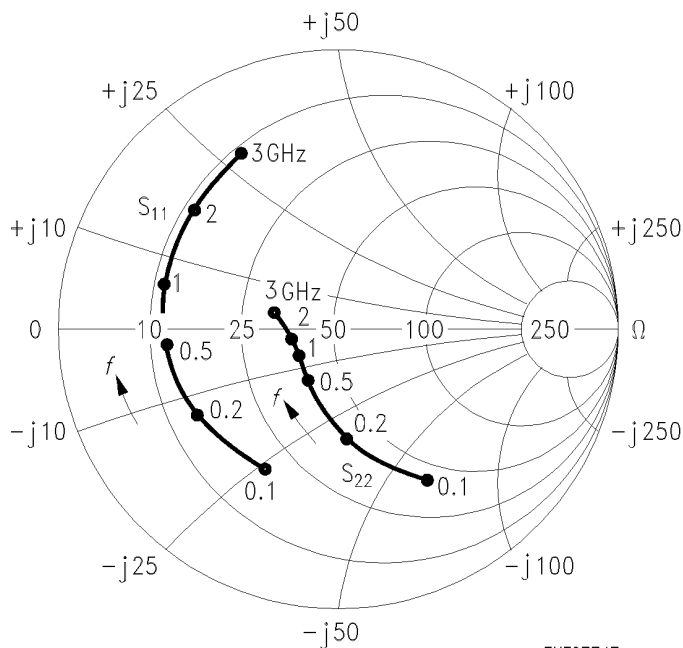

EHT07747

*S*₁₂, *S*₂₁ = *f*(*f*)

*I*_C = 50 mA, *V*_{CE} = 8 V, *Z*₀ = 50 Ω

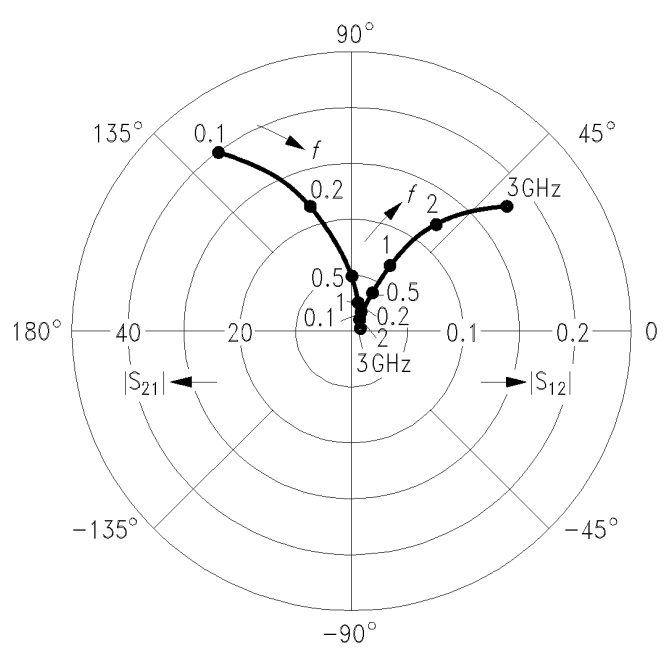

EHT07748

Common Emitter Large Signal Parameters

Linear output voltage $V_o = f(I_c)$

$V_{CE} = 8 \text{ V}$, $d_{IM} = 60 \text{ dB}$, $f_1 = 806 \text{ MHz}$,
 $f_2 = 810 \text{ MHz}$, $Z_S = Z_L = 50 \Omega$

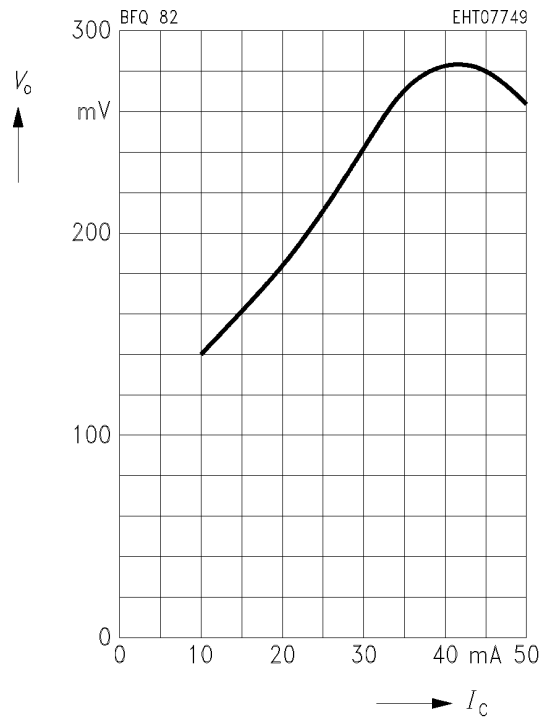

Note:

The transistor is driven by 2 adjacent signals f_1, f_2 with equal output power levels P_o for each carrier.

The distance d_{IM} between P_o and the third order intermodulation products P_{IM} ($2f_1 - f_2$ or $2f_2 - f_1$) is:

$$d_{IM} = P_o - P_{IM}$$

where $P_o = 10 \log (V_o^2 / (50 \Omega \cdot 1 \text{ mW}))$ (dBm)

and $V_o =$ linear output voltage of each carrier.

The 3rd order intercept point IP_3 will be found by extrapolation to the point where P_{IM} would be identical to P_o :

$$IP_3 (\text{output}) = P_o + d_{IM}/2.$$

Linear output voltages for other d_{IM} (e.g. 50 dB) can be calculated thereby.



LittleDiode supplies new, hard to find or obsolete electronic components and semiconductors all over the world.

With over two million different components listed you are sure to find the part you need.

Feel free to visit us today at our online store:

LittleDiode.com

Looking forward to providing you with the best possible service.