

Silicon Variable Capacitance Diode

BB 304A

Preliminary Data

- For FM tuners
- Monolithic chip with common cathode for perfect tracking of both diodes
- Uniform "square law" characteristics
- Ideal Hifi tuning device when used in Low-distortion back-to back configuration
- Color-coded capacitance subgroups available (see characteristics)

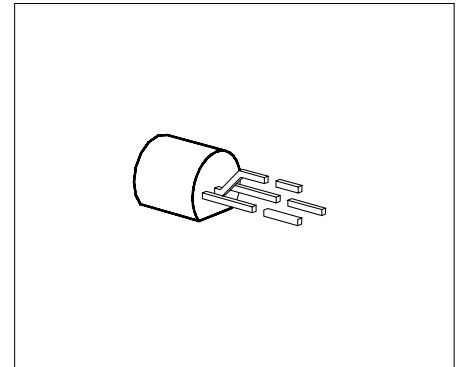

Type	Ordering Code (tape and reel)	Pin Configuration			Marking	Package
		1	2	3		
BB 304A	Q62702-B118	A1	C1/C2	A2	color coded capacitance groups	TO-92

Maximum Ratings

Parameter	Symbol	Values	Unit
Reverse voltage	V_R	18	V
Peak reverse voltage ($R \geq 10 \Omega$)	V_{RM}	20	V
Forward current $T_A \leq 60 \text{ }^\circ\text{C}$	I_F	50	mA
Storage temperature range	T_{stg}	- 55 ... + 150	$^\circ\text{C}$

Thermal Resistance

Junction-ambient	$R_{th JA}$	\leq	K/W
------------------	-------------	--------	-----

Electrical Characteristics

at $T_A = 25\text{ °C}$, unless otherwise specified.

Parameter	Symbol	Value			Unit
		min.	typ.	max.	

DC Characteristics

Reverse current $V_R = 16\text{ V}$ $V_R = 16\text{ V}, T_A = 60\text{ °C}$	I_R	– –	– –	20 200	nA
Diode capacitance $V_R = 2\text{ V}, f = 1\text{ MHz}$	C_T	42	–	47.5	pF
Capacitance ratio $V_R = 2\text{ V} \dots 8\text{ V}, f = 1\text{ MHz}$	C_{T2}/C_{T8}	1.65	–	– 1.75	–
Series resistance $V_R = 38\text{ V}, f = 100\text{ MHz}$	r_S	–	0.25	0.4	Ω
Q factor $C_T = 38\text{ pF}, f = 100\text{ MHz}$	Q	100	170	–	–
Diode capacitance $V_R = 2\text{ V}, f = 1\text{ MHz}$ Subgroup: red yellow white green blue	C_T	42 43 44 45 46	– – – – –	43.5 44.5 45.5 46.5 47.5	pF

Package Outline

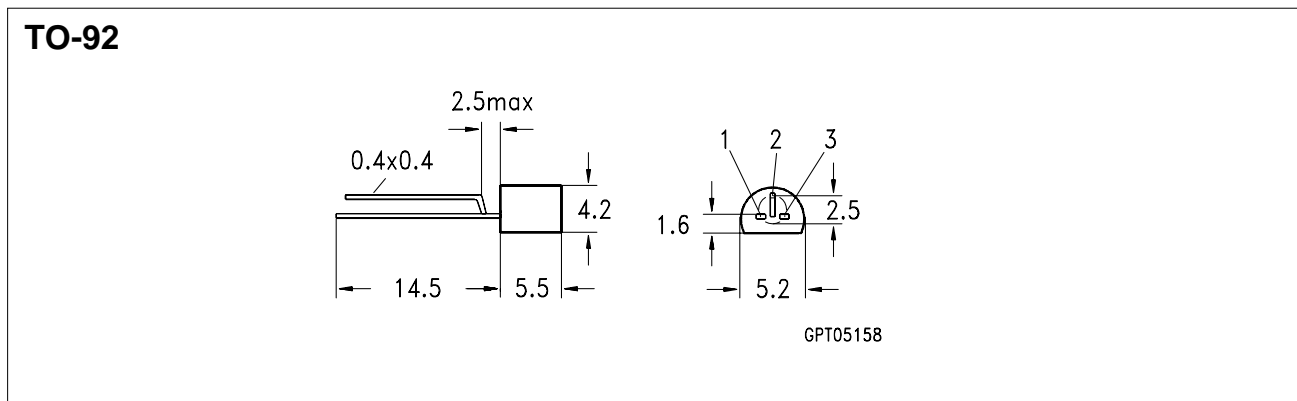

Diode capacitance $C_T = f(V_R)$
per diode $f = 1$ MHz

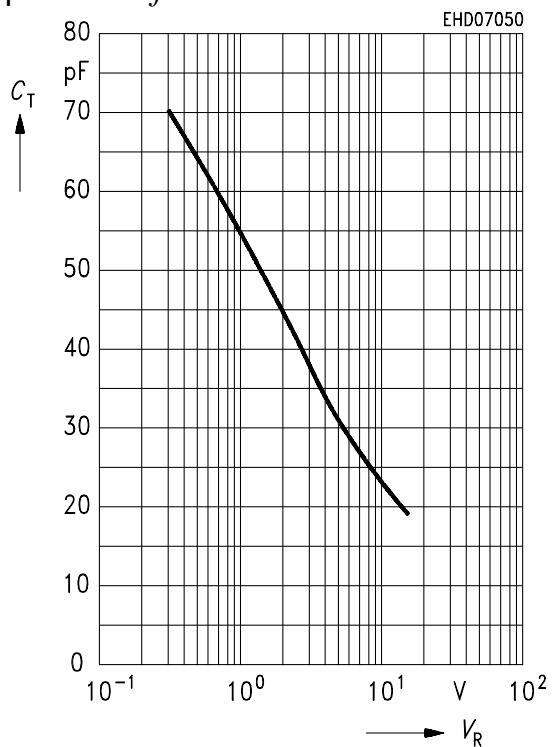

Capacitance ratio $C_T/C_{Tref} = f(V_R)$
per diode; $V_{ref} = 1$ V, 2 V, $f = 1$ MHz

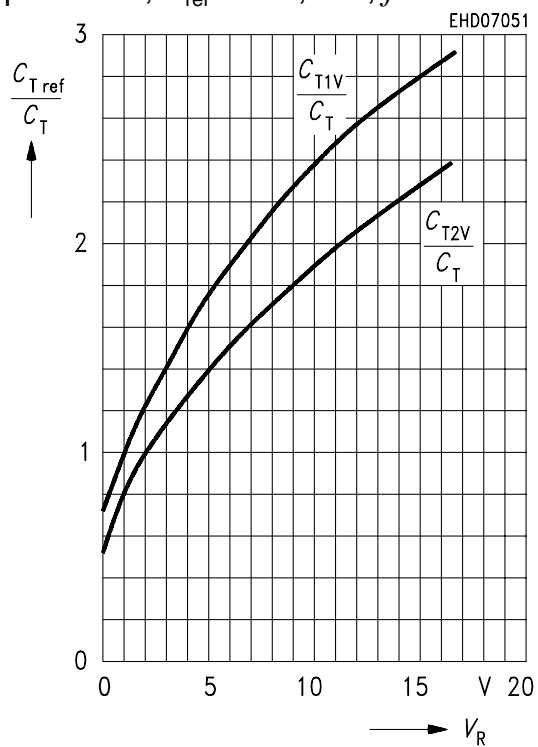

Temperature coefficient $T_{CC} = f(V_R)$
per diode, $f = 1$ MHz

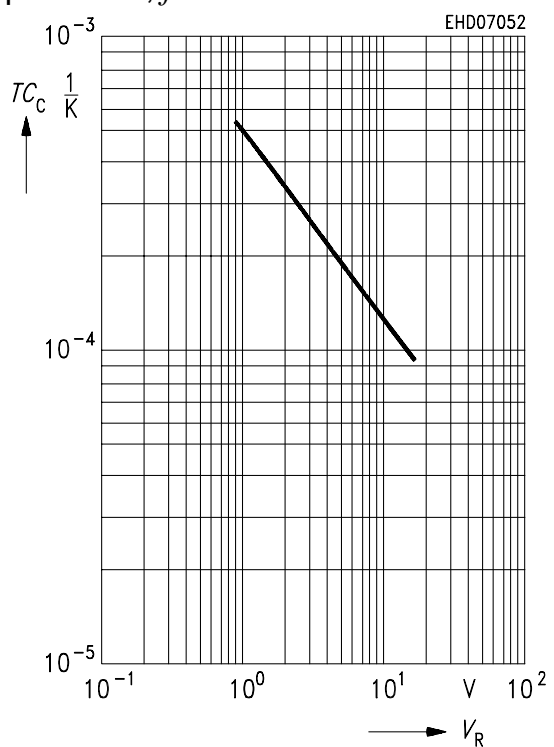



LittleDiode supplies new, hard to find or obsolete electronic components and semiconductors all over the world.

With over two million different components listed you are sure to find the part you need.

Feel free to visit us today at our online store:

LittleDiode.com

Looking forward to providing you with the best possible service.