

SIEMENS AKTIENGESELLSCHAFT

Main ratings

Drain-source voltage  $V_{DS} = 800$  V  
 Continuous drain current  $I_D = 3,6$  A  
 Drain-source on-resistance  $R_{DS(on)} = 3,0 \Omega$

N-Channel

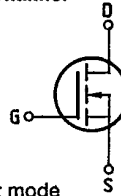

**Description** FREDET with fast-recovery reverse diode, N-channel, enhancement mode  
**Case** Plastic package 15 in accordance with DIN 41869 or TO 218 AA (TOP 3) in accordance with JEDEC.  
 The drain terminal is conductively connected to the mounting flange.  
 Approx. weight 4,5 g

Type	Ordering code
BUZ 360	C67078-A3204-A2

Available from Sep 1987

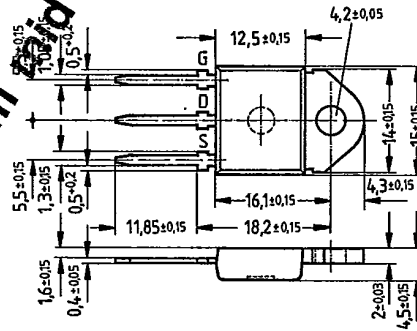

Dimensions in mm

Maximum ratings

Description	Symbols	Ratings	Units	Conditions
Drain-source voltage	$V_{DS}$	800	V	
Drain-gate voltage	$V_{DGR}$	800	V	$R_{GS} = 20 \text{ k}\Omega$
Continuous drain current	$I_D$	3,6	A	$T_C = 25 \text{ }^\circ\text{C}$
Pulsed drain current	$I_{Dpuls}$	14	A	$T_C = 25 \text{ }^\circ\text{C}$
Gate-source voltage	$V_{GS}$	$\pm 20$	V	
Max. power dissipation	$P_D$	75	W	$T_C = 25 \text{ }^\circ\text{C}$
Operating and storage temperature range	$T_j$ $T_{stg}$	$-55 \dots +150$	$^\circ\text{C}$	
DIN humidity category		E	-	DIN 40 040
IEC climatic category		55/150/56	-	DIN IEC 68-1

Thermal resistance

Chip - case	$R_{th JC}$	$\leq 1,67$	K/W
Chip - ambient	$R_{th JA}$	$\leq 45$	K/W

## SIEMENS AKTIENGESELLSCHAFT

## Electrical characteristics

(at  $T_j = 25^\circ\text{C}$  unless otherwise specified)

Description	Symbol	Characteristics			Unit	Conditions
		min.	typ.	max.		
<b>Static ratings</b>						
Drain-source breakdown voltage	$V_{(BR)DSS}$	800	—	—	V	$V_{GS} = 0V$ $I_D = 0,25mA$
Gate threshold voltage	$V_{GS(th)}$	2,1	3,0	4,0		$V_{DS} = V_{GS}$ $I_D = 1mA$
Zero gate voltage drain current	$I_{DSS}$	—	20	250	$\mu A$	$T_j = 25^\circ\text{C}$ $T_j = 125^\circ\text{C}$ $V_{DS} = 800V$ $V_{GS} = 0V$
Gate-source leakage current	$I_{GSS}$	—	10	100	nA	$V_{GS} = 20V$ $V_{DS} = 0V$
Drain-source on-resistance	$R_{DS(on)}$	—	2,0	3,0	$\Omega$	$V_{GS} = 10V$ $I_D = 2,3A$
<b>Dynamic ratings</b>						
Forward transconductance	$g_{fs}$	1,0	2,4	—	S	$V_{DS} = 25V$ $I_D = 2,3A$
Input capacitance	$C_{iss}$	—	1,6	2,1	nF	$V_{GS} = 0V$ $V_{DS} = 25V$ $f = 1MHz$
Output capacitance	$C_{oss}$	—	90	150	pF	
Reverse transfer capacitance	$C_{rss}$	—	30	55		
Turn-on time $t_{on}$ ( $t_{on} = t_{d(on)} + t_r$ )	$t_{d(on)}$	—	30	45	ns	$V_{CC} = 30V$ $I_D = 2,3A$ $V_{GS} = 10V$ $R_{GS} = 50\Omega$
	$t_r$	—	50	60		
Turn-off time $t_{off}$ ( $t_{off} = t_{d(off)} + t_f$ )	$t_{d(off)}$	—	100	140		
	$t_f$	—	60	80		
<b>Fast-recovery reverse diode</b>						
Continuous reverse drain current	$I_{DR}$	—	—	3,6	A	$T_C = 25^\circ\text{C}$
Pulsed reverse drain current	$I_{DRM}$	—	—	14		
Diode forward on-voltage	$V_{SD}$	—	1,15	1,5	V	$I_F = 2 \times I_{DR}$ $V_{GS} = 0V, T_j = 25^\circ\text{C}$
Reverse recovery time	$t_{rr}$	—	180	250	ns	$T_j = 25^\circ\text{C}$ $T_j = 150^\circ\text{C}$ $I_F = I_{DR}$ $df/dt = 100A/\mu s$ $V_R = 100V$
		—	220	300		
Reverse recovery charge	$Q_{rr}$	—	0,85	1,2	$\mu C$	
		—	2,6	5,0		
Repetitive peak reverse current	$I_{RRM}$	—	—	—	A	
		—	15	—		$T_j = 25^\circ\text{C}$ $T_j = 150^\circ\text{C}$

SIEMENS AKTIENGESELLSCHAFT

Power dissipation  $P_D = f(T_C)$

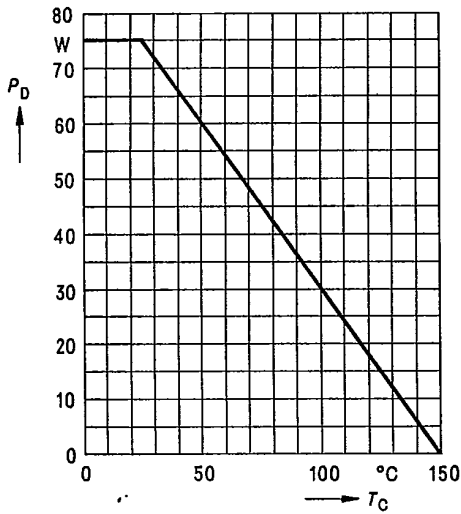

Typical output characteristics  $I_D = f(V_{DS})$   
parameter: 80  $\mu$ s pulse test,  
 $T_J = 25^\circ\text{C}$

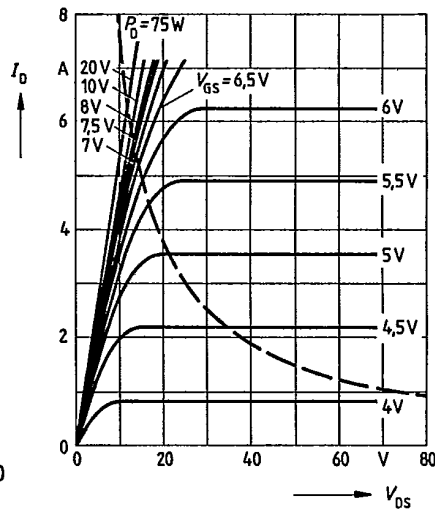

Safe operating area  $I_D = f(V_{DS})$   
parameter:  $D = 0.01$ ,  $T_C = 25^\circ\text{C}$

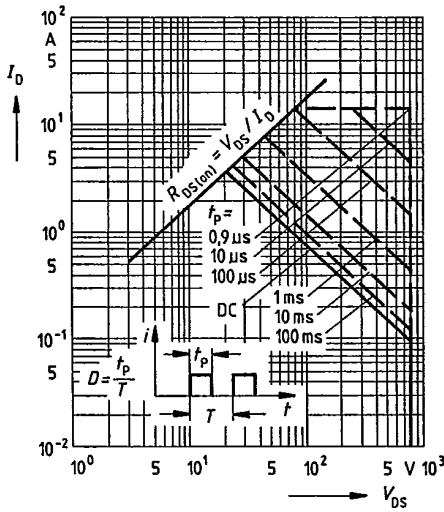

Typical transfer characteristic  $I_D = f(V_{GS})$   
parameter: 80  $\mu$ s pulse test,  
 $V_{DS} = 25\text{V}$ ,  $T_J = 25^\circ\text{C}$

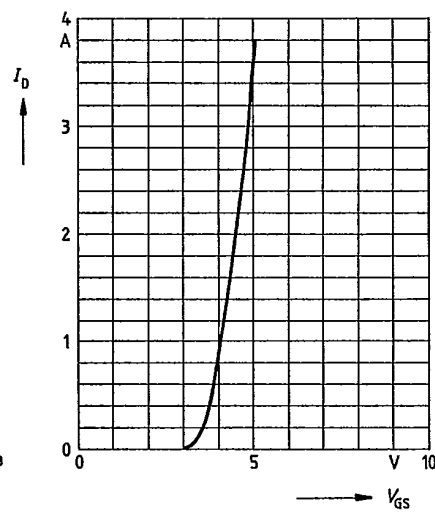

SIEMENS AKTIENGESELLSCHAFT

Typical drain-source on-state resistance

$R_{DS(on)} = f(I_D)$   
parameter:  $V_{GS} = T_j = 25^\circ\text{C}$

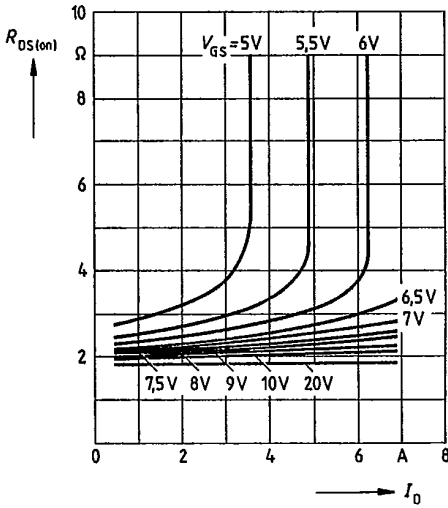

Drain-source on-state resistance

$R_{DS(on)} = f(T_j)$   
parameter:  $I_D = 2.3\text{A}, V_{GS} = 10\text{V}$   
(spread)

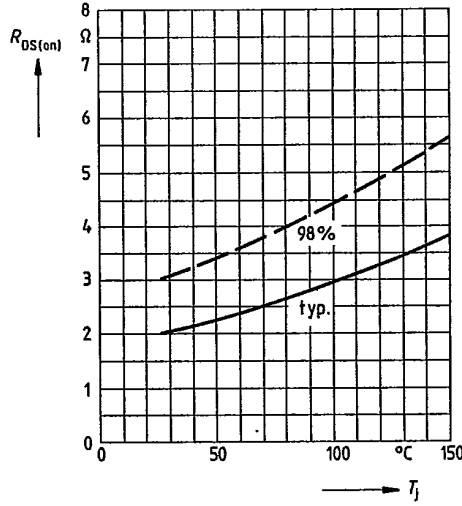

Typical transconductance  $g_{fs} = f(I_D)$

parameter: 80  $\mu\text{s}$  pulse test,  
 $V_{DS} = 25\text{V}, T_j = 25^\circ\text{C}$

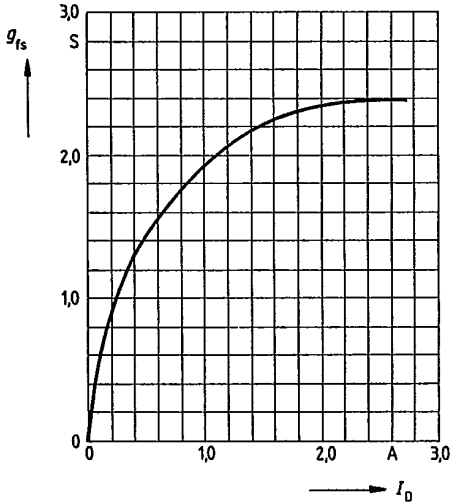

Gate threshold voltage  $V_{GS(th)} = f(T_j)$

parameter:  $V_{DS} = V_{GS}, I_D = 1\text{mA}$   
(spread)

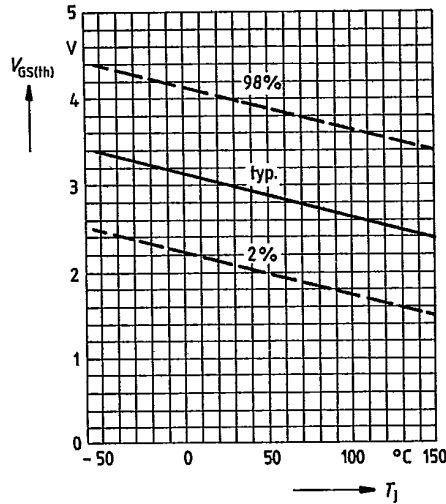

— SIEMENS AKTIENGESELLSCHAFT —

Typical capacitances  $C = f(V_{DS})$   
 parameter:  $V_{GS} = 0, f = 1\text{MHz}$

Continuous drain current  $I_D = f(T_C)$   
 parameter:  $V_{GS} \geq 10\text{V}$

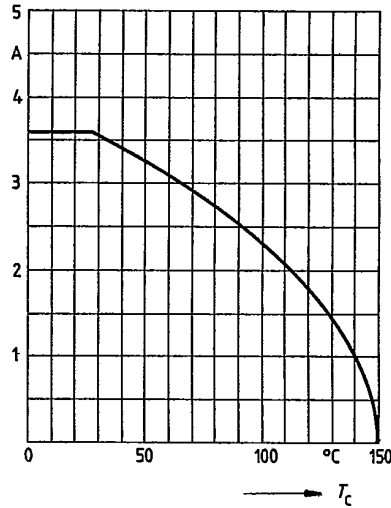
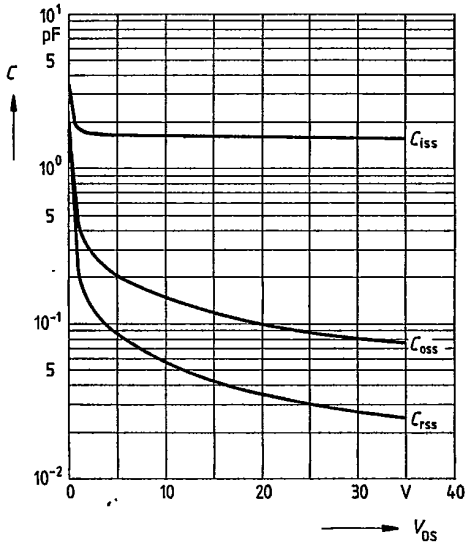

Forward characteristic of reverse diode

$I_F = f(V_{SD})$   
 parameter:  $T_j, t_p = 80 \mu\text{s}$   
 (spread)

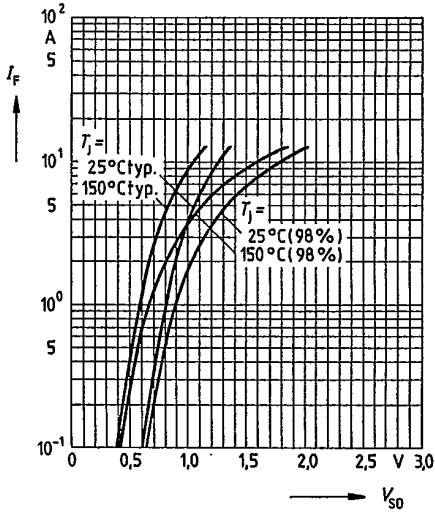

782

1364

G-01

— SIEMENS AKTIENGESELLSCHAFT —

Transient thermal impedance  $Z_{thJC} = f(t)$   
 parameter:  $D = t_p/T$

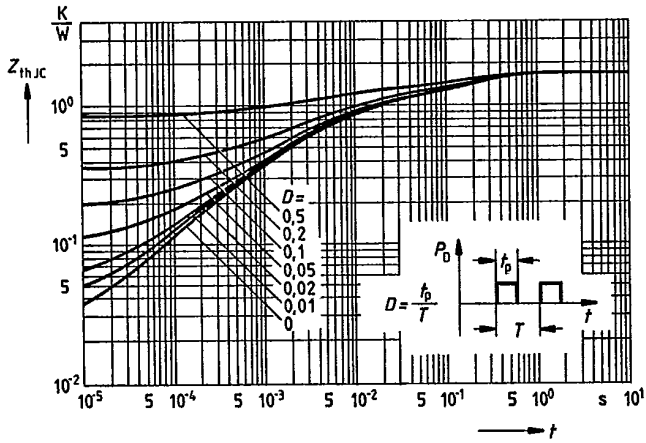

Typical gate-charge  $V_{GS} = f(Q_{Gate})$   
 parameter:  $I_D \text{ pulse} = 5A$

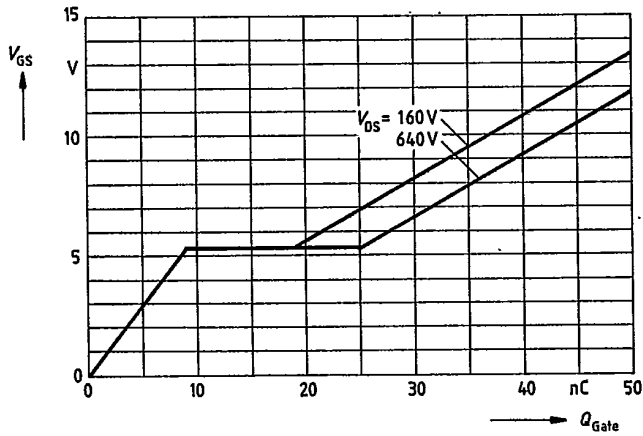



LittleDiode supplies new, hard to find or obsolete electronic components and semiconductors all over the world.

With over two million different components listed you are sure to find the part you need.

Feel free to visit us today at our online store:

**[LittleDiode.com](http://LittleDiode.com)**

Looking forward to providing you with the best possible service.