

Silicon Schottky Diode

- Rectifier Schottky diode for telecommunication and industrial applications
- High reverse voltage
- For power supply
- For clamping and protection in high voltage applications

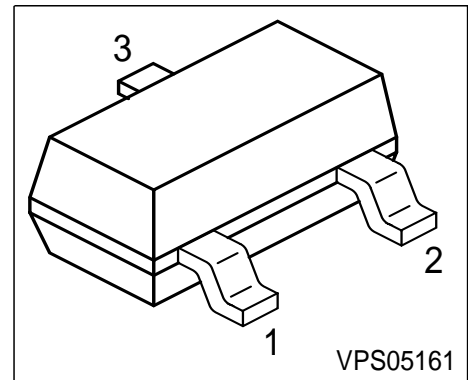

ESD: Electrostatic discharge sensitive device, observe handling precaution!

Type	Marking	Pin Configuration			Package
BAT240A	4Ms	1=C1/A2	2 = C2	3 = A1	SOT23

Maximum Ratings

Parameter	Symbol	Value	Unit
Diode reverse voltage	V_R	240	V
Peak reverse voltage	V_{RM}	250	
Forward current	I_F	400	mA
Surge forward current ($t \leq 10\text{ms}$)	I_{FSM}	1	A
Total power dissipation, $T_S = 28\text{ }^\circ\text{C}$	P_{tot}	400	mW
Junction temperature	T_j	80	$^\circ\text{C}$
Storage temperature	T_{stg}	-55 ... 150	

Thermal Resistance

Junction - soldering point ¹⁾	R_{thJS}	≤ 305	K/W
--	------------	------------	-----

¹⁾For calculation of R_{thJA} please refer to Application Note Thermal Resistance

Electrical Characteristics at $T_A = 25\text{ °C}$, unless otherwise specified.

Parameter	Symbol	Values			Unit
		min.	typ.	max.	
DC characteristics					
Breakdown voltage $I_{(BR)} = 500\text{ }\mu\text{A}$	$V_{(BR)}$	240	-	-	V
Reverse current $V_R = 200\text{ V}$ $V_R = 240$	I_R	- -	5 -	- 500	μA
Forward voltage $I_F = 10\text{ mA}$ $I_F = 20\text{ mA}$ $I_F = 50\text{ mA}$	V_F	- - -	0.325 0.37 0.47	- - -	V
AC characteristics					
Diode capacitance $V_R = 10\text{ V}$, $f = 1\text{ MHz}$	C_T	-	11.5	-	pF

Forward current $I_F = f(T_S)$

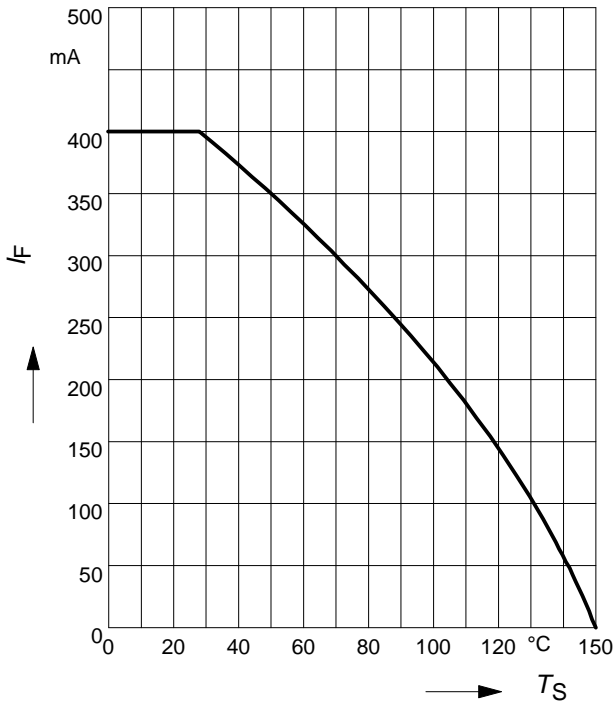

Forward current $I_F = f(V_F)$

$T_A = \text{parameter}$

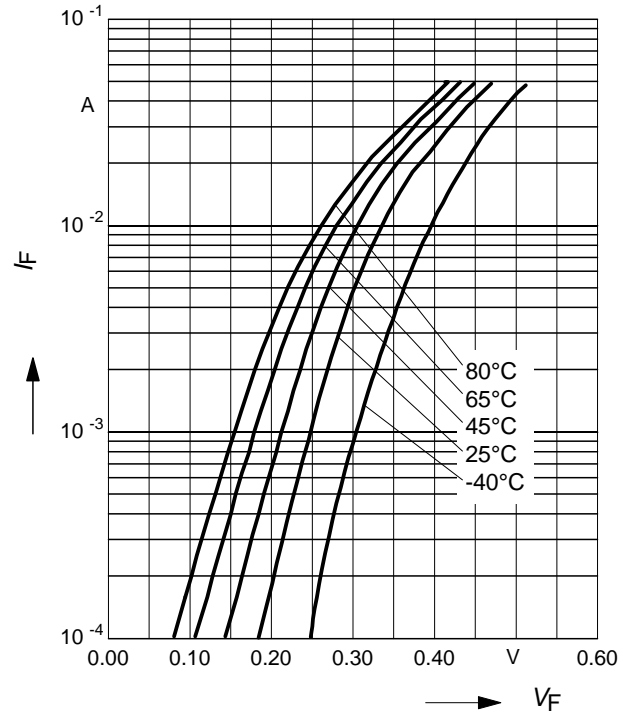

Permissible Pulse Load $R_{thJS} = f(t_p)$

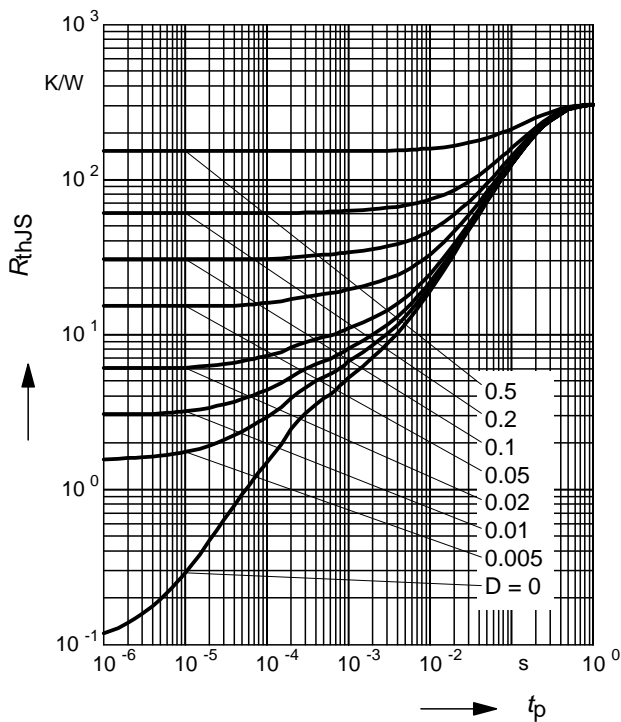

Permissible Pulse Load

$I_{Fmax} / I_{FDC} = f(t_p)$

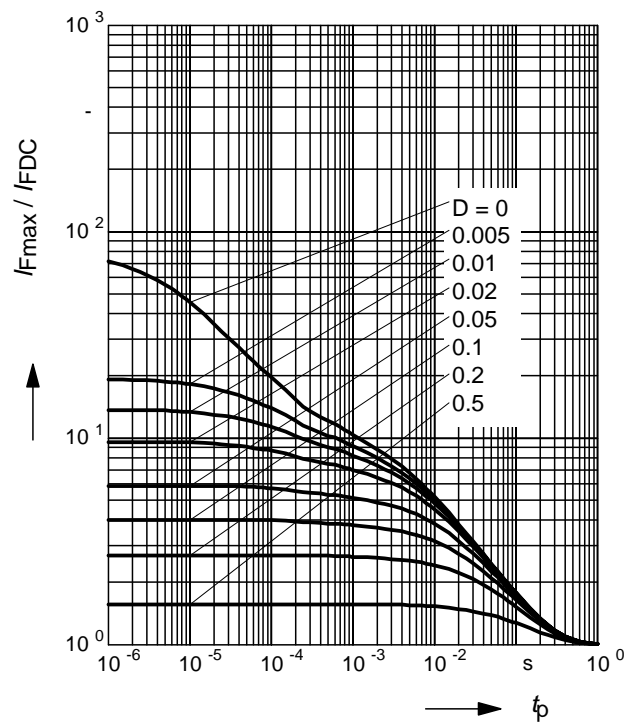

Derating curve reverse voltage

$V_R = f(T_A)$; $t_p =$ Parameter

Duty cycle < 0.01

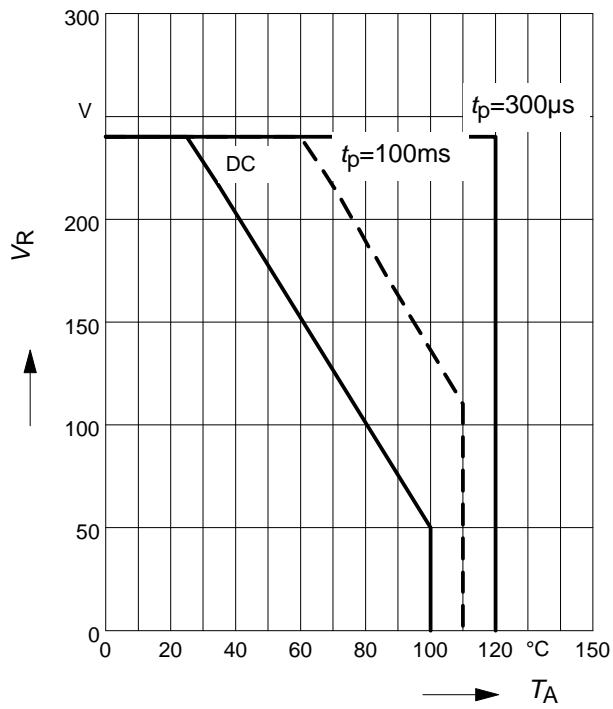



LittleDiode supplies new, hard to find or obsolete electronic components and semiconductors all over the world.

With over two million different components listed you are sure to find the part you need.

Feel free to visit us today at our online store:

LittleDiode.com

Looking forward to providing you with the best possible service.