

NPN Silicon RF Transistor

- For low noise, low-power amplifiers in mobile communication systems (pager, cordless telephone) at collector currents from 0.2 mA to 8 mA
- $f_T = 7.5$ GHz
 $F = 1.5$ dB at 900 MHz

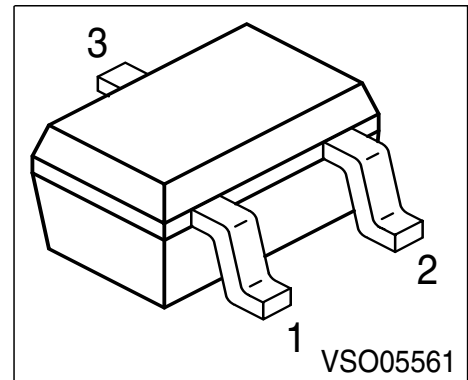

ESD: Electrostatic discharge sensitive device, observe handling precaution!

Type	Marking	Pin Configuration			Package
BFR 280W	REs	1 = B	2 = E	3 = C	SOT-323

Maximum Ratings

Parameter	Symbol	Value	Unit
Collector-emitter voltage	V_{CEO}	8	V
Collector-emitter voltage	V_{CES}	10	
Collector-base voltage	V_{CBO}	10	
Emitter-base voltage	V_{EBO}	2	
Collector current	I_C	10	mA
Base current	I_B	1.2	
Total power dissipation, $T_S = 115$ °C ¹⁾	P_{tot}	80	mW
Junction temperature	T_j	150	°C
Ambient temperature	T_A	-65 ... 150	
Storage temperature	T_{stg}	-65 ... 150	

Thermal Resistance

Junction - soldering point	R_{thJS}	≤ 435	K/W
----------------------------	------------	-------	-----

¹⁾ T_S is measured on the collector lead at the soldering point to the pcb

Electrical Characteristics at $T_A = 25^\circ\text{C}$, unless otherwise specified.

Parameter	Symbol	Values			Unit
		min.	typ.	max.	
DC characteristics					
Collector-emitter breakdown voltage $I_C = 1\text{ mA}, I_B = 0$	$V_{(BR)CEO}$	8	-	-	V
Collector-emitter cutoff current $V_{CE} = 10\text{ V}, V_{BE} = 0$	I_{CES}	-	-	100	μA
Collector-base cutoff current $V_{CB} = 8\text{ V}, I_E = 0$	I_{CBO}	-	-	100	nA
Emitter-base cutoff current $V_{EB} = 1\text{ V}, I_C = 0$	I_{EBO}	-	-	1	μA
DC current gain $I_C = 3\text{ mA}, V_{CE} = 5\text{ V}$	h_{FE}	30	100	200	-

Electrical Characteristics at $T_A = 25^\circ\text{C}$, unless otherwise specified.

Parameter	Symbol	Values			Unit
		min.	typ.	max.	
AC characteristics (verified by random sampling)					
Transition frequency $I_C = 6 \text{ mA}$, $V_{CE} = 5 \text{ V}$, $f = 500 \text{ MHz}$	f_T	5	7.5	-	GHz
Collector-base capacitance $V_{CB} = 5 \text{ V}$, $f = 1 \text{ MHz}$	C_{cb}	-	0.27	0.45	pF
Collector-emitter capacitance $V_{CE} = 5 \text{ V}$, $f = 1 \text{ MHz}$	C_{ce}	-	0.18	-	
Emitter-base capacitance $V_{EB} = 0.5 \text{ V}$, $f = 1 \text{ MHz}$	C_{eb}	-	0.22	-	
Noise figure $I_C = 1.5 \text{ mA}$, $V_{CE} = 5 \text{ V}$, $Z_S = Z_{Sopt}$, $f = 900 \text{ MHz}$ $f = 1.8 \text{ GHz}$	F	-	1.5	-	dB
		-	2	-	
Power gain, maximum stable ¹⁾ $I_C = 3 \text{ mA}$, $V_{CE} = 5 \text{ V}$, $Z_S = Z_{Sopt}$, $Z_L = Z_{Lopt}$, $f = 900 \text{ MHz}$ $f = 1.8 \text{ GHz}$	G_{ms}	-	17.5	-	
		-	13.5	-	
Transducer gain $I_C = 3 \text{ mA}$, $V_{CE} = 5 \text{ V}$, $Z_S = Z_L = 50\Omega$, $f = 900 \text{ MHz}$ $I_C = 3 \text{ mA}$, $V_{CE} = 5 \text{ V}$	$ S_{21e} ^2$	-	14	-	
		-	9	-	

$$^1G_{ms} = |S_{21} / S_{12}|$$

SPICE Parameters (Gummel-Poon Model, Berkley-SPICE 2G.6 Syntax) :

Transistor Chip Data

IS =	6.472	fA	BF =	89.888	-	NF =	1.0801	-
VAF =	25.609	V	IKF =	0.073457	A	ISE =	15.596	fA
NE =	1.6163	-	BR =	20.238	-	NR =	0.83403	-
VAR =	5.6909	V	IKR =	0.012696	A	ISC =	1.409	fA
NC =	1.0651	-	RB =	15	Ω	IRB =	0.031958	mA
RBM =	14.999	Ω	RE =	2.4518	Ω	RC =	6.989	Ω
CJE =	36.218	fF	VJE =	0.70035	V	MJE =	0.69773	-
TF =	11.744	ps	XTF =	0.21585	-	VTF =	0.2035	V
ITF =	6.2179	mA	PTF =	0	deg	CJC =	252.99	fF
VJC =	1.1943	V	MJC =	0.30017	-	XCJC =	0.19188	-
TR =	2.3693	ns	CJS =	0	fF	VJS =	0.75	V
MJS =	0	-	XTB =	0	-	EG =	1.11	eV
XTI =	3	-	FC =	0.96275	-	TNOM	300	K

All parameters are ready to use, no scaling is necessary.

Extracted on behalf of SIEMENS Small Signal Semiconductors by:
 Institut für Mobil-und Satellitentechnik (IMST)

© 1996 SIEMENS AG

Package Equivalent Circuit:

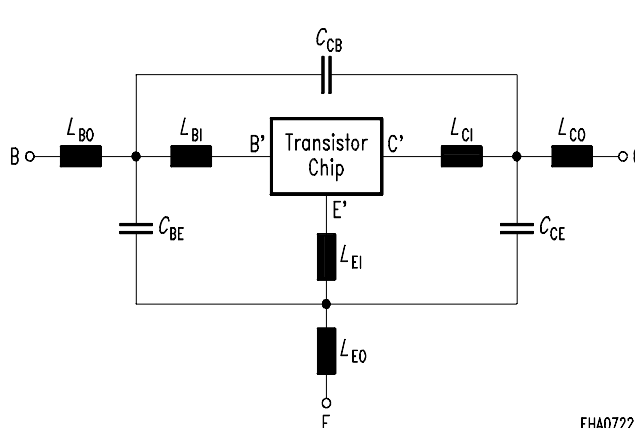

L_{BI} =	0.57	nH
L_{BO} =	0.4	nH
L_{EI} =	0.43	nH
L_{EO} =	0.5	nH
L_{CI} =	0	nH
L_{CO} =	0.41	nH
C_{BE} =	61	fF
C_{CB} =	101	fF
C_{CE} =	175	fF

Valid up to 6GHz

For examples and ready to use parameters please contact your local Infineon Technologies distributor or sales office to obtain a Infineon Technologies CD-ROM or see Internet: <http://www.infineon.com/products/discrete/index.htm>

Total power dissipation $P_{tot} = f(T_A^*, T_S)$

* Package mounted on epoxy

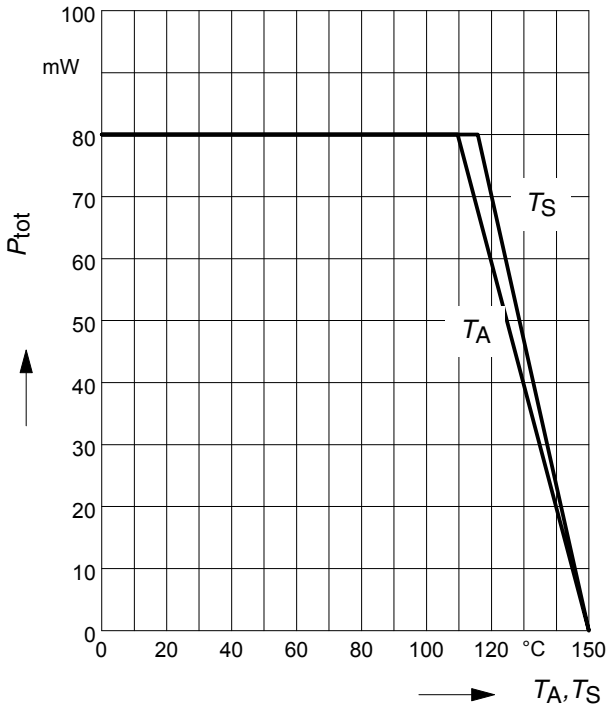

Permissible Pulse Load $R_{thJS} = f(t_p)$

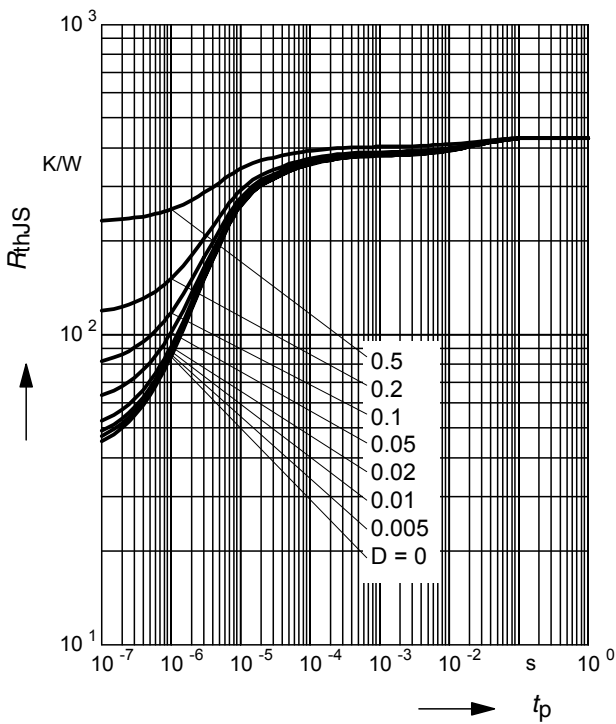

Permissible Pulse Load

$P_{totmax}/P_{totDC} = f(t_p)$

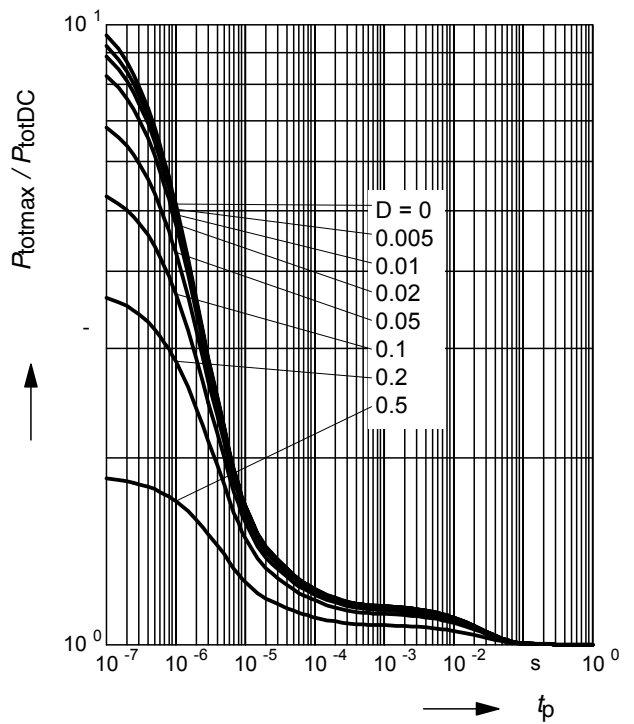

Collector-base capacitance $C_{cb} = f(V_{CB})$

$f = 1\text{MHz}$

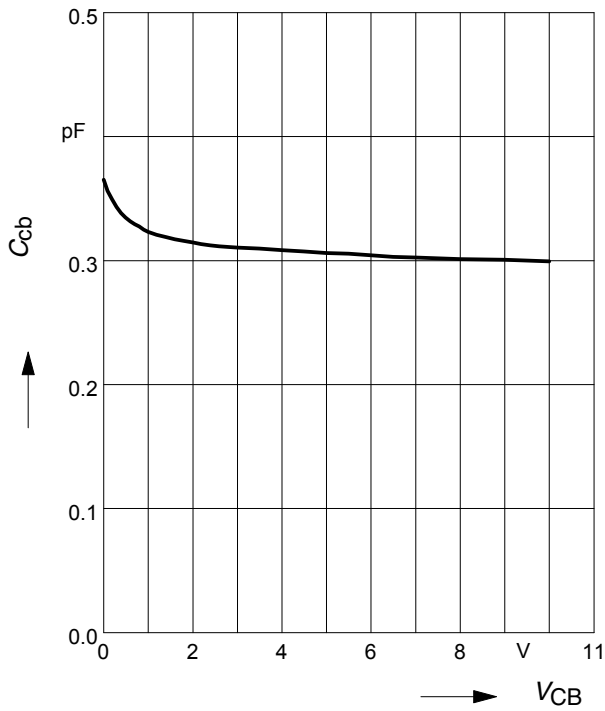

Transition frequency $f_T = f(I_C)$

$V_{CE} = \text{Parameter}$

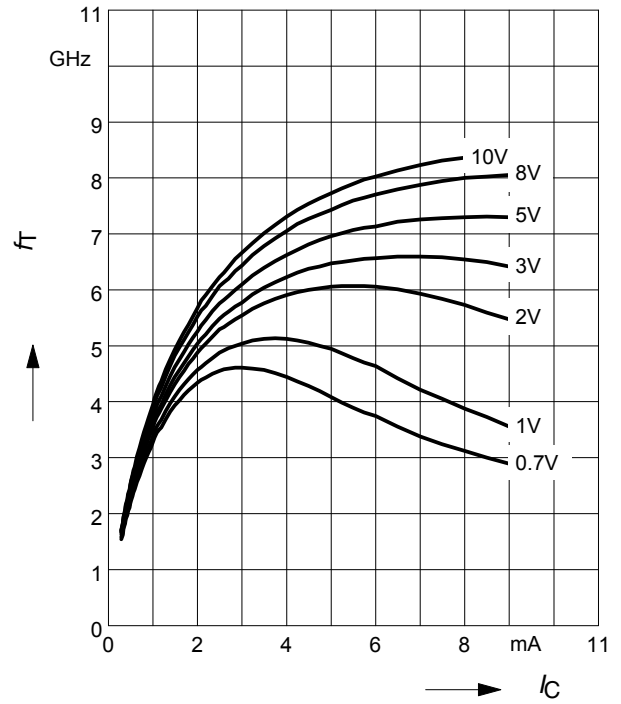

Power Gain $G_{ma}, G_{ms} = f(I_C)$

$f = 0.9\text{GHz}$

$V_{CE} = \text{Parameter}$

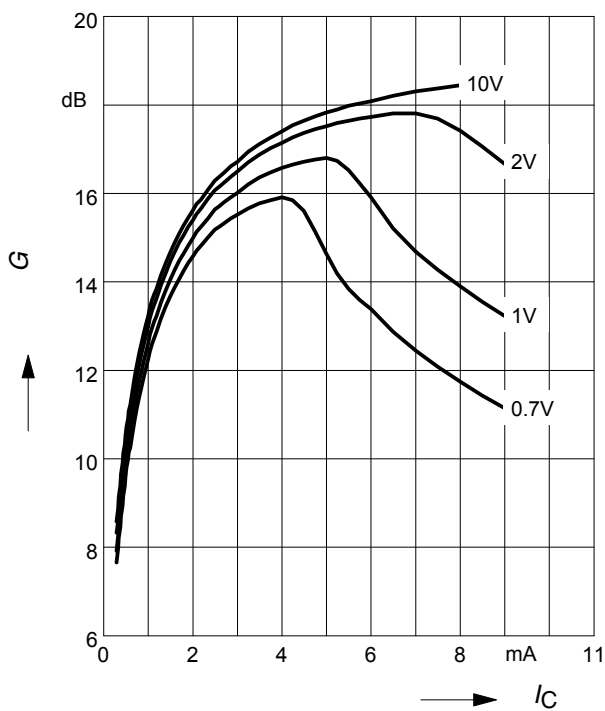

Power Gain $G_{ma}, G_{ms} = f(I_C)$

$f = 1.8\text{GHz}$

$V_{CE} = \text{Parameter}$

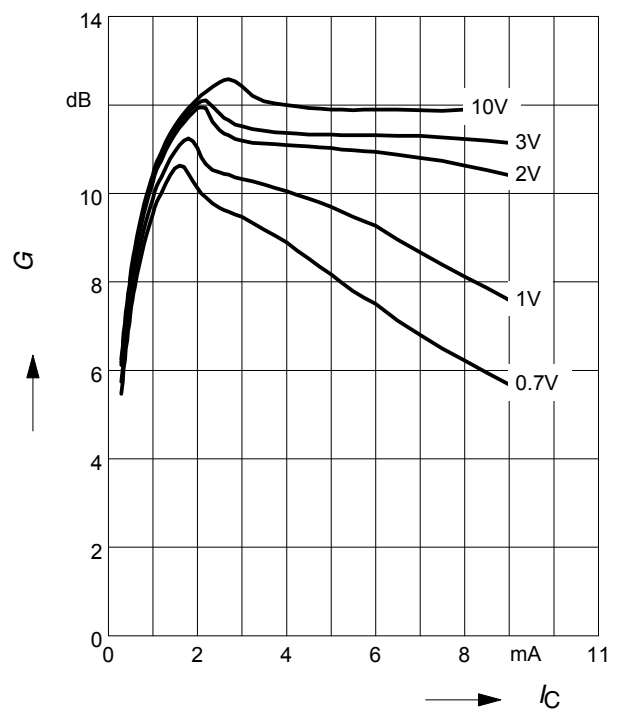

Power Gain $G_{ma}, G_{ms} = f(V_{CE})$: _____

$|S_{21}|^2 = f(V_{CE})$: -----

f = Parameter

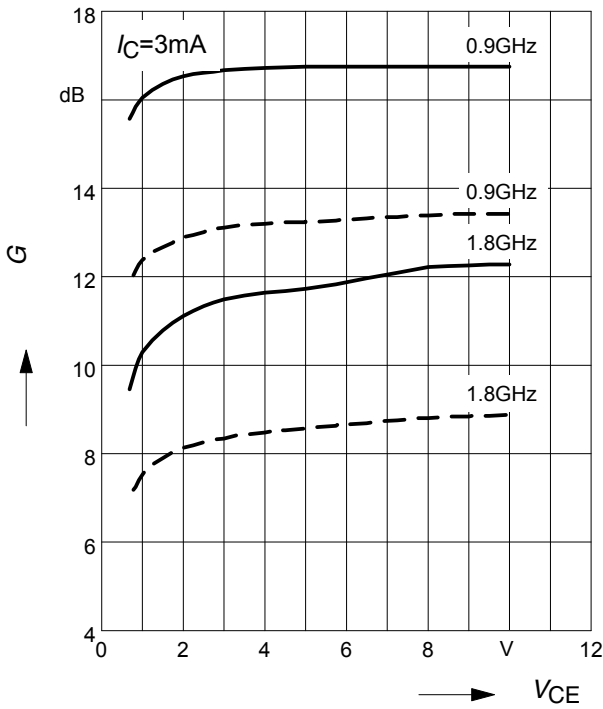

Intermodulation Intercept Point $IP_3 = f(I_C)$

(3rd order, Output, $Z_S = Z_L = 50\Omega$)

V_{CE} = Parameter, $f = 900\text{MHz}$

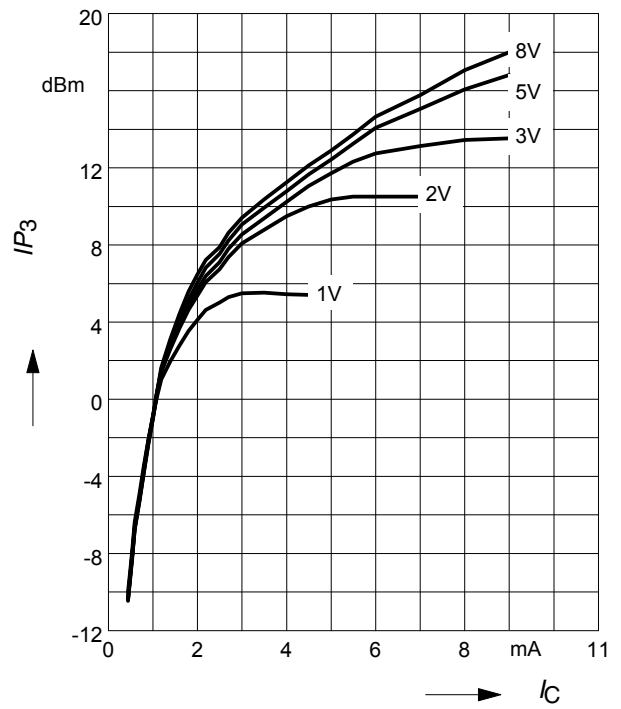

Power Gain $G_{ma}, G_{ms} = f(f)$

V_{CE} = Parameter

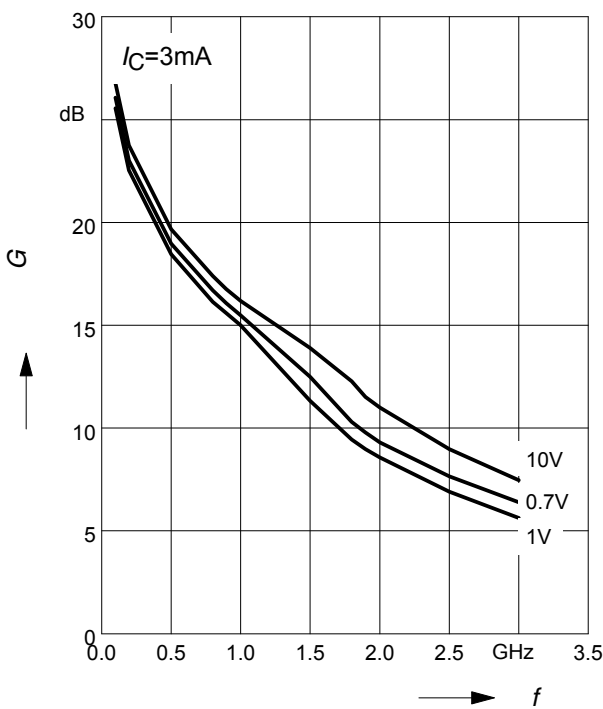

Power Gain $|S_{21}|^2 = f(f)$

V_{CE} = Parameter

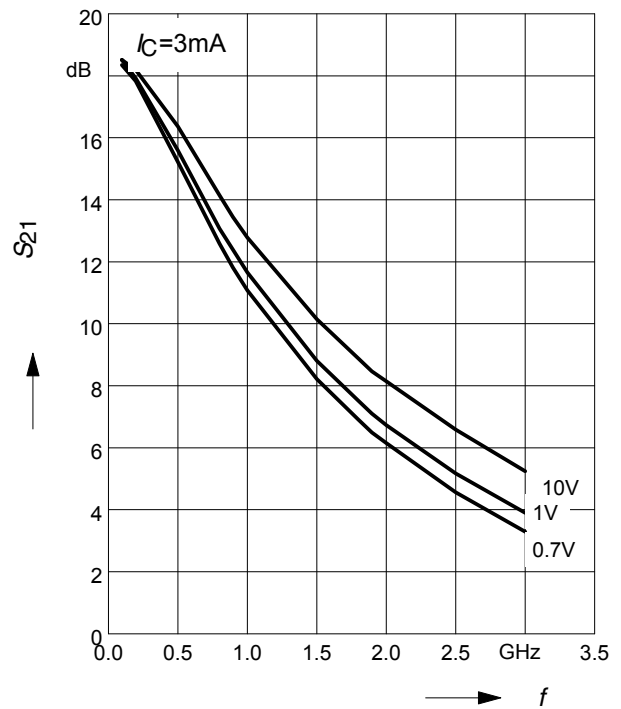



LittleDiode supplies new, hard to find or obsolete electronic components and semiconductors all over the world.

With over two million different components listed you are sure to find the part you need.

Feel free to visit us today at our online store:

LittleDiode.com

Looking forward to providing you with the best possible service.