

Silicon Variable Capacitance Diode

Description

The 1T362 is a variable capacitance diode designed for electronic tuning of TV tuners, and the super miniature package allows the tuner miniaturization.

Features

- Super miniature package
- Low series resistance 0.65 Ω Max. (f=470 MHz)
- Large capacitance ratio 6.5 Typ. (C<sub>2</sub>/C<sub>25</sub>)
- Small leakage current 10 nA Max. (V<sub>R</sub>=28 V)
- Maximum capacitance deviation  
3 % Max.

Applications

Electronic tuning for TV and CATV

Structure

Silicon epitaxial planar type diode

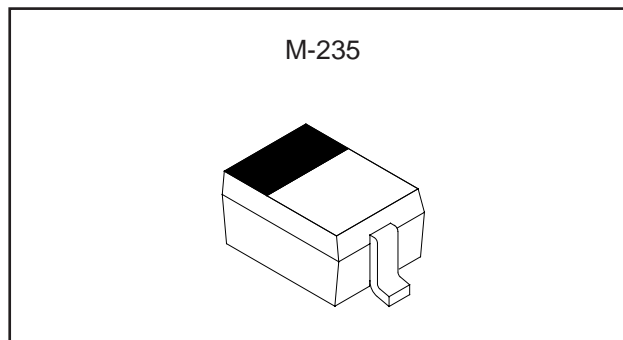

Absolute Maximum Ratings (T<sub>a</sub>=25 °C)

- Reverse voltage V<sub>R</sub> 30 V
- Peak reverse voltage V<sub>RM</sub> 35 V  
(R<sub>L</sub>≥10 kΩ)
- Operating temperature Topr 85 °C
- Storage temperature Tstg -55 to +150 °C

Electrical Characteristics

(T<sub>a</sub>=25 °C)

Item	Symbol	Conditions	Min.	Typ.	Max.	Unit
Reverse current	I <sub>R</sub>	V <sub>R</sub> =28 V			10	nA
Diode capacitance	C <sub>2</sub>	V <sub>R</sub> =2 V, f=1 MHz	14.01	15.00	16.33	pF
	C <sub>25</sub>	V <sub>R</sub> =25 V, f=1 MHz	2.10	2.27	2.39	pF
Capacitance ratio	C <sub>2</sub> /C <sub>25</sub>	f=1 MHz		6.5		
Series resistance	r <sub>S</sub>	C <sub>D</sub> =14 pF, f=470 MHz		0.57	0.65	Ω
Maximum-capacitance deviation in the same ranking	ΔC	V <sub>R</sub> =2 to 25 V, f=1 MHz			3	%

Sony reserves the right to change products and specifications without prior notice. This information does not convey any license by any implication or otherwise under any patents or other right. Application circuits shown, if any, are typical examples illustrating the operation of the devices. Sony cannot assume responsibility for any problems arising out of the use of these circuits.

Diode capacitance vs. Reverse voltage

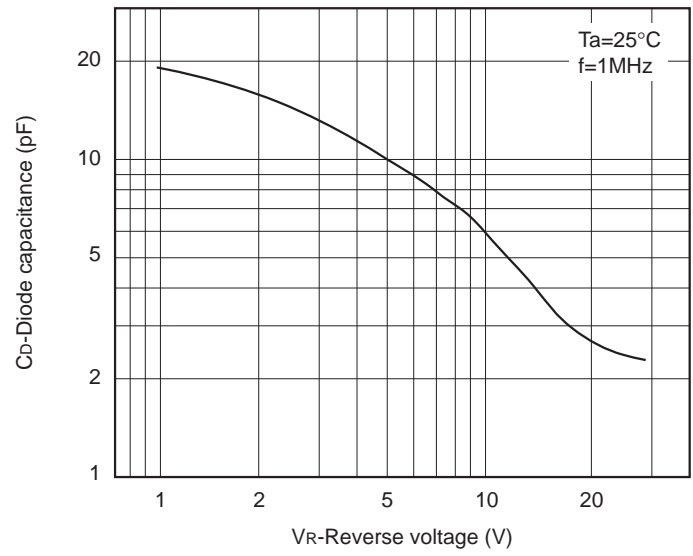

Reverse voltage vs. Ambient temperature

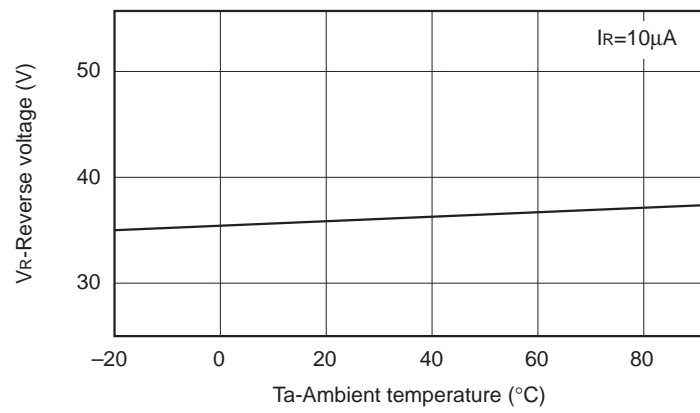

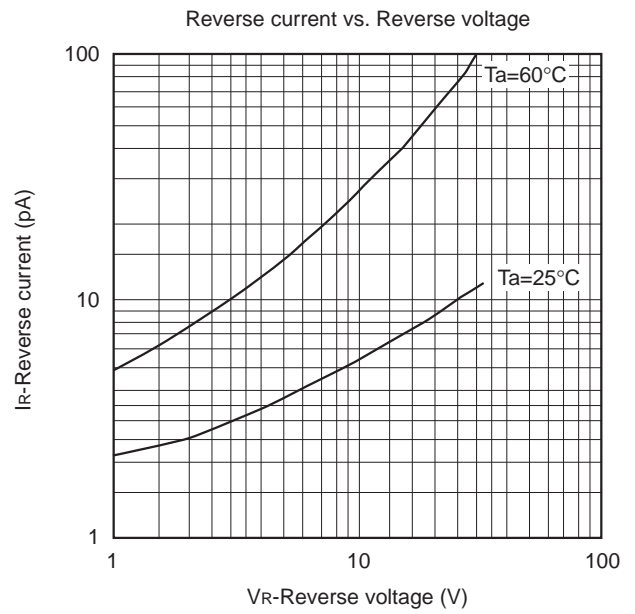
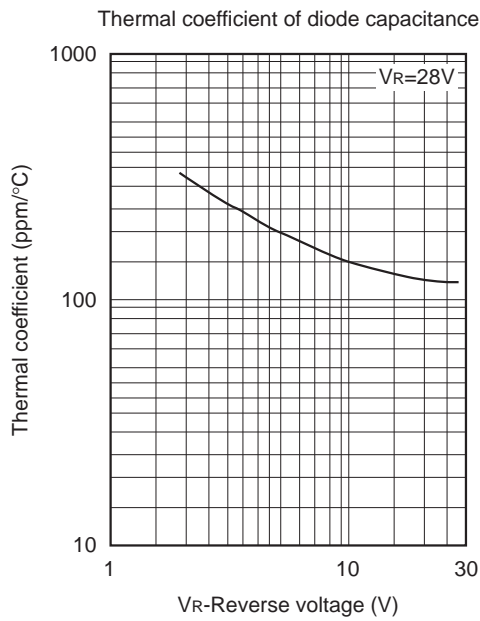
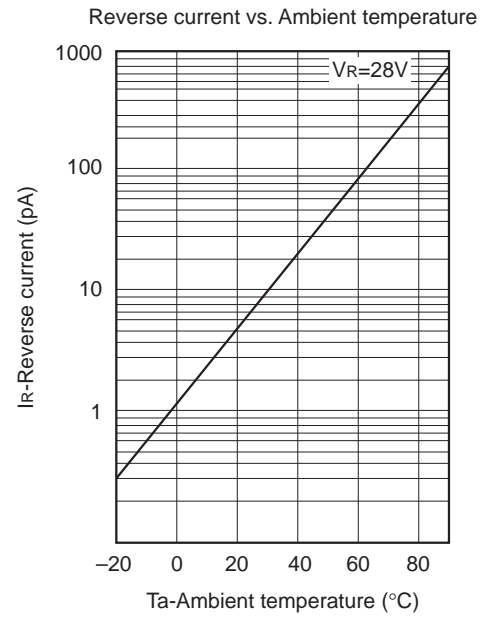
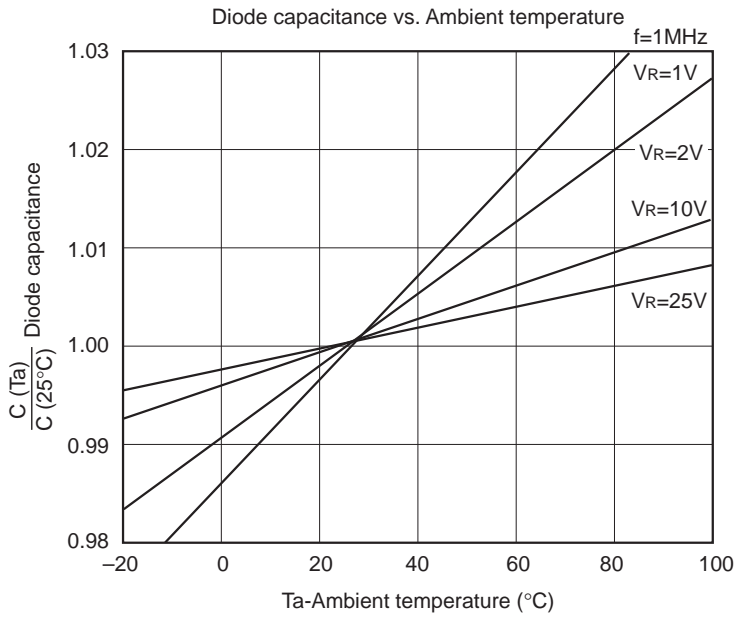

Package Outline Unit : mm

M-235

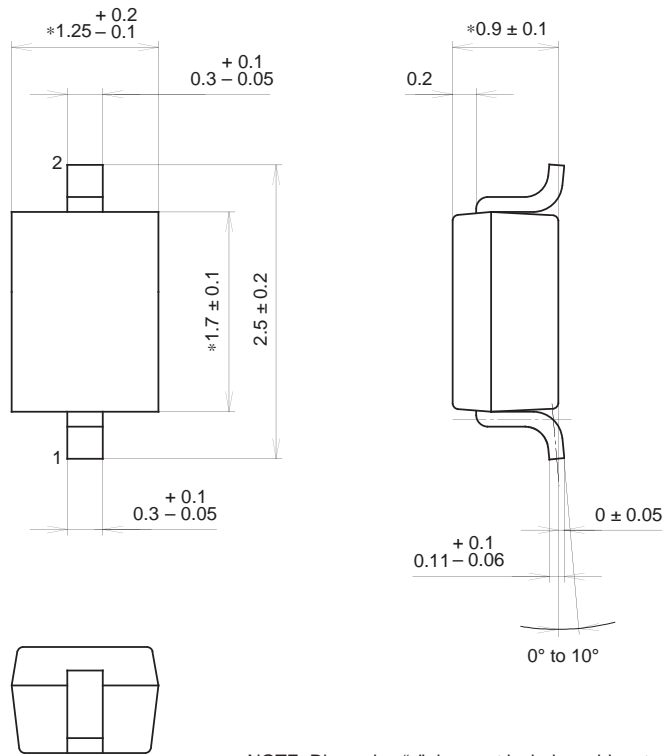

NOTE: Dimension "\*" does not include mold protrusion.

SONY CODE	M-235
EIAJ CODE	_____
JEDEC CODE	_____

PACKAGE WEIGHT	0.1g
----------------	------

Marking

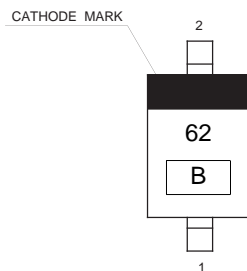

- Notes
- 1) B: Lot No. (Year and Month of manufacture)  
Year; Last one digit  
Month; A, B, C (for Oct. to Dec.)  
1 to 9 (for Jan. to Sept.)



LittleDiode supplies new, hard to find or obsolete electronic components and semiconductors all over the world.

With over two million different components listed you are sure to find the part you need.

Feel free to visit us today at our online store:

**[LittleDiode.com](http://LittleDiode.com)**

Looking forward to providing you with the best possible service.