

**UHF band VCO**

**Description**

The 1T367 is a variable capacitance diode housed in super miniature package, designed for UHF band VCO.

**Features**

- Super miniature package
- Small series resistance  
rs=0.3 Ω (Typ.)

**Applications**

- UHF band VCO
- Local oscillator for telephone
- Local oscillator for cellular systems

**Structure**

Silicon epitaxial planar type diode

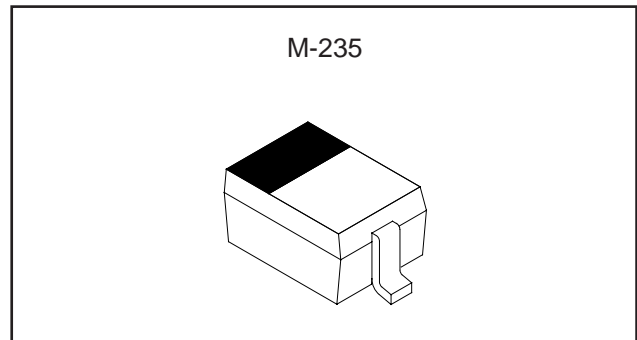

**Absolute Maximum Ratings (Ta=25 °C)**

- Reverse voltage           VR           15           V
- Operating temperature   Topr       -35 to +85   °C
- Storage temperature     Tstg      -65 to +150 °C

**Electrical Characteristics**

(Ta=25 °C)

Item	Symbol	Conditions	Min.	Typ.	Max.	Unit
Reverse current	IR	VR=15 V			3	nA
Diode capacitance	C2	VR=2 V, f=1 MHz	14.3	15.0	16.0	pF
	C10	VR=10 V, f=1 MHz	5.5	6.0	6.5	pF
Capacitance ratio	C2/C10		2.2	2.5		
Series resistance	rs	VR=5 V, f=470 MHz		0.3	0.4	Ω

Sony reserves the right to change products and specifications without prior notice. This information does not convey any license by any implication or otherwise under any patents or other right. Application circuits shown, if any, are typical examples illustrating the operation of the devices. Sony cannot assume responsibility for any problems arising out of the use of these circuits.

Example of Representative Characteristics

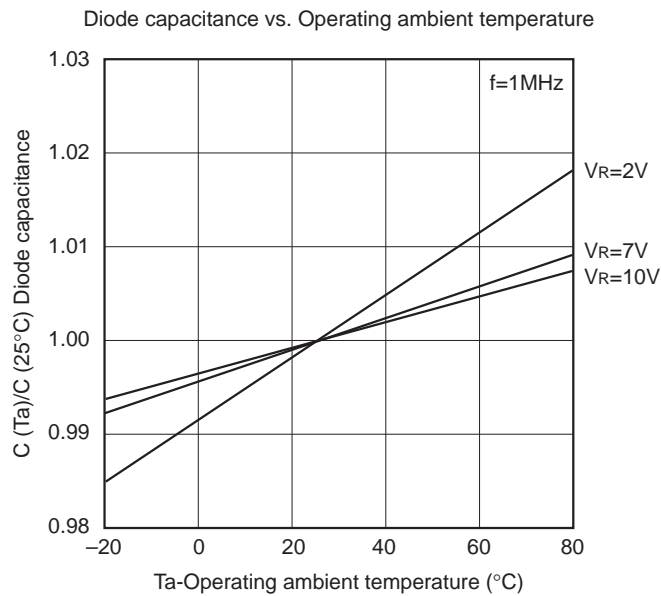
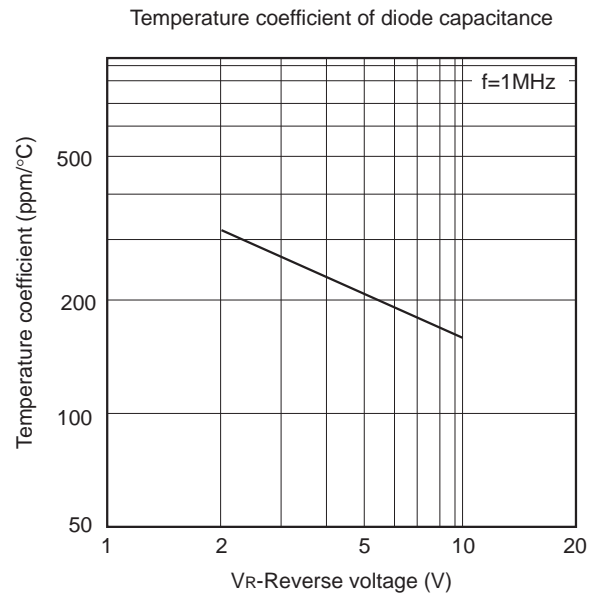
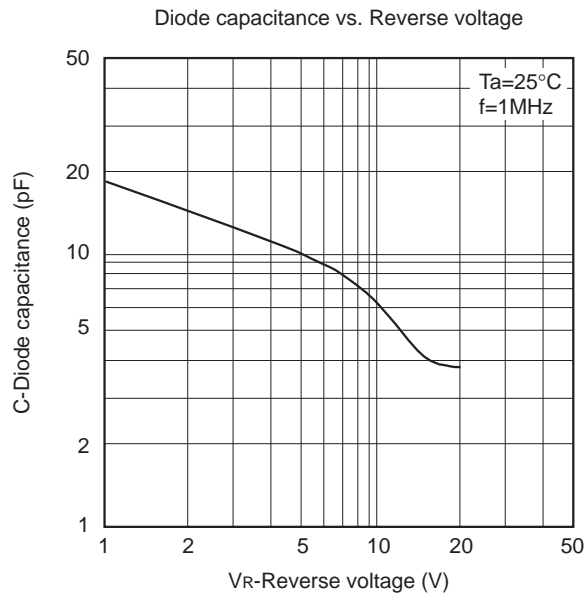

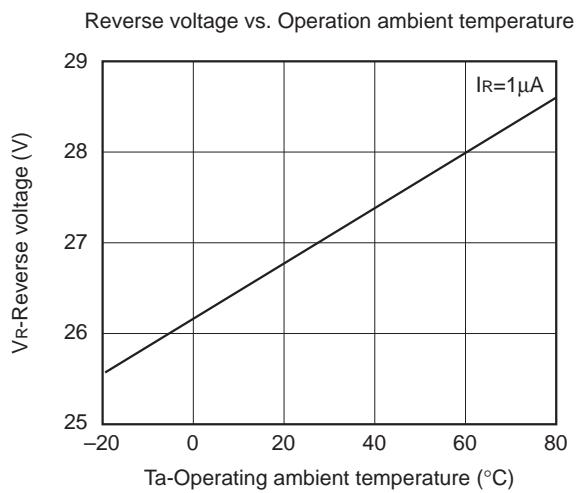
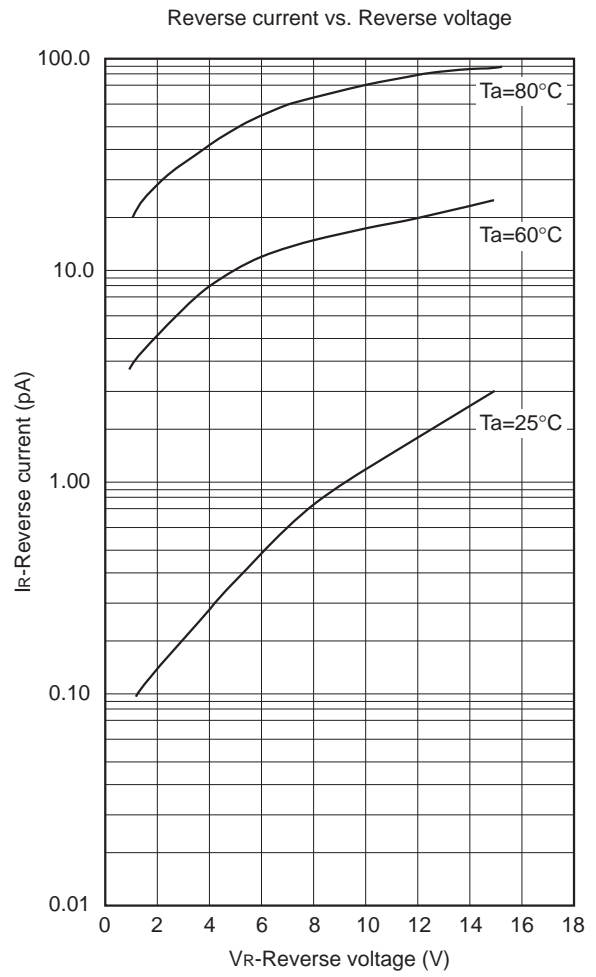
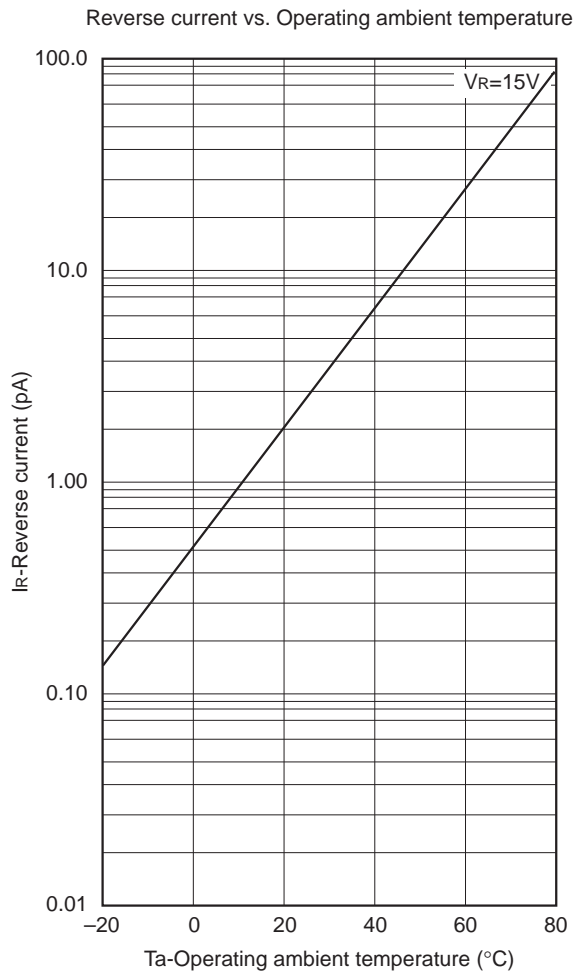

Package Outline Unit : mm

M-235

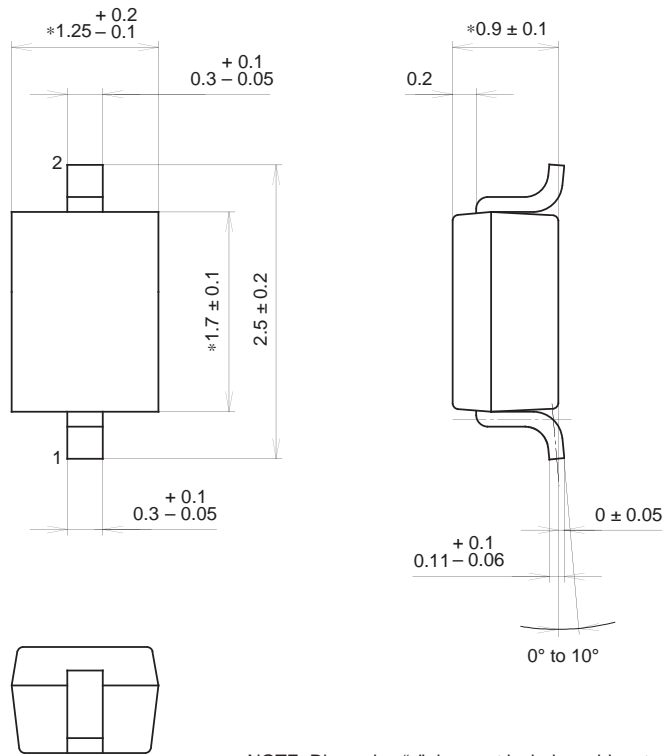

NOTE: Dimension "\*" does not include mold protrusion.

SONY CODE	M-235
EIAJ CODE	_____
JEDEC CODE	_____

PACKAGE WEIGHT	0.1g
----------------	------

Marking

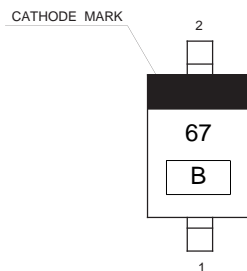

- Notes
- 1) B: Lot No. (Year and Month of manufacture)  
Year; Last one digit  
Month; A, B, C (for Oct. to Dec.)  
1 to 9 (for Jan. to Sept.)



LittleDiode supplies new, hard to find or obsolete electronic components and semiconductors all over the world.

With over two million different components listed you are sure to find the part you need.

Feel free to visit us today at our online store:

[LittleDiode.com](http://LittleDiode.com)

Looking forward to providing you with the best possible service.