

Variable Capacitance Diode

Description

The 1T397 is a variable capacitance diode designed for the electronic tuning of wide band CATV tuners, and it has a super miniature package.

Features

- Super miniature package
- Large capacitance ratio $C_2/C_{25}=14.5$ Min.
 $C_1/C_{28}=21.5$ Min.
 $C_{25}/C_{28}=1.03$ Min.
- Small series resistance $r_s=1.1 \Omega$ Max.
- High reverse voltage $V_R=34$ V

Structure

Silicon epitaxial planar-type diode

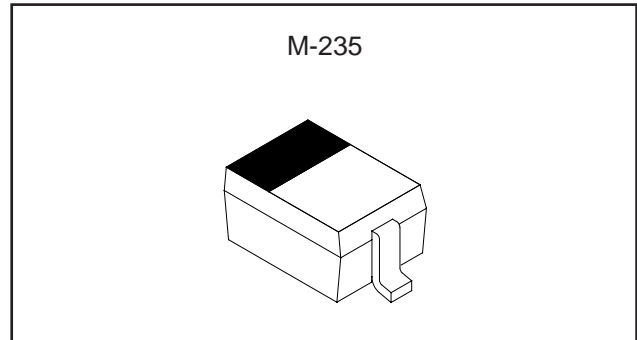

Absolute Maximum Ratings (Ta=25 °C)

- Reverse voltage V_R 34 V
- Operating temperature
Topr -20 to +75 °C
- Storage temperature
Tstg -65 to +150 °C

Electrical Characteristics

(Ta=25 °C)

Item	Symbol	Conditions	Min.	Typ.	Max.	Unit
Reverse current	I_R	$V_R=28$ V			10	nA
Reverse voltage	V_R	$I_R=1 \mu A$	34			V
Diode capacitance	C_2	$V_R=2$ V, $f=1$ MHz	42.9		51.0	pF
	C_{25}	$V_R=25$ V, $f=1$ MHz	2.60		3.03	pF
Capacitance ratio	C_2/C_{25}		14.5	15.5		
	C_1/C_{28}		21.5			
	C_{25}/C_{28}		1.03			
Series resistance	r_s	$C_D=14$ pF, $f=470$ MHz			1.1	Ω
Capacitance deviation in a matching group	ΔC	$V_R=1$ to 28 V			2.0	%

Sony reserves the right to change products and specifications without prior notice. This information does not convey any license by any implication or otherwise under any patents or other right. Application circuits shown, if any, are typical examples illustrating the operation of the devices. Sony cannot assume responsibility for any problems arising out of the use of these circuits.

Diode capacitance vs. Reverse voltage temperature

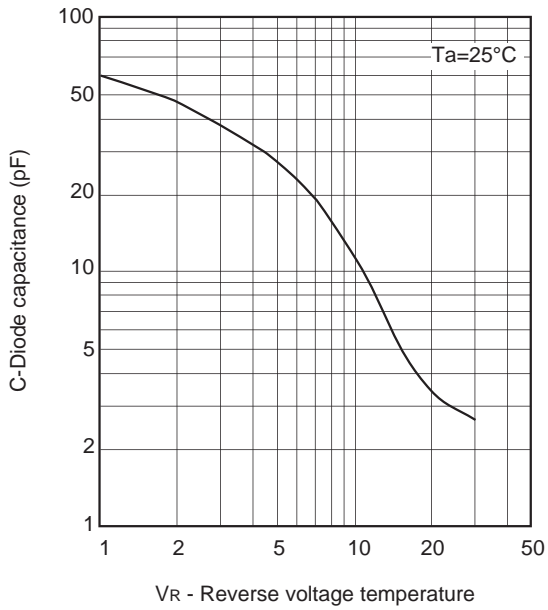

Reverse current vs. Ambient temperature

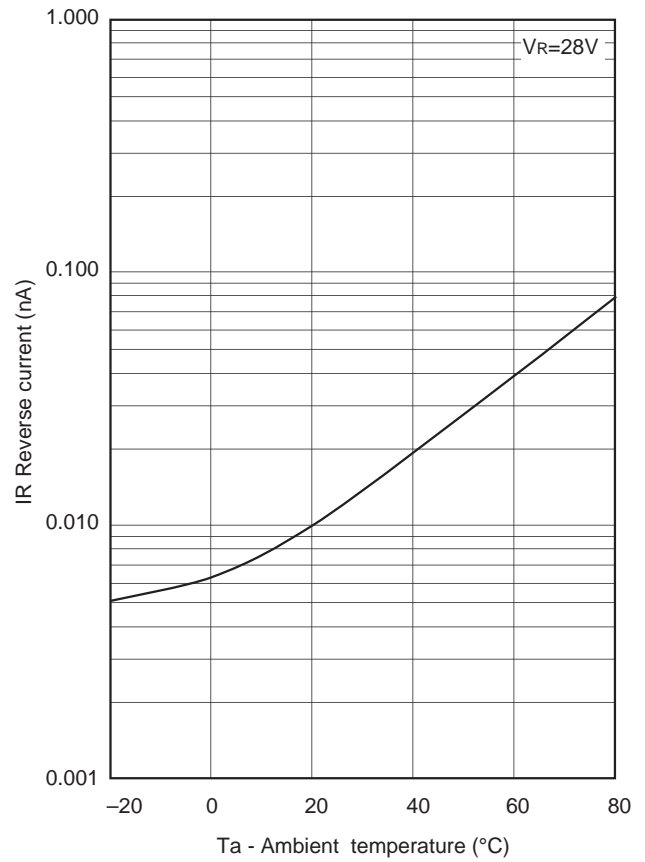

Forward voltage vs. Ambient temperature

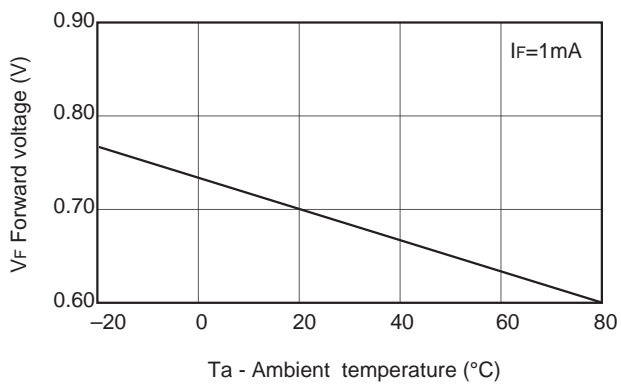

Reverse voltage vs. Ambient temperature

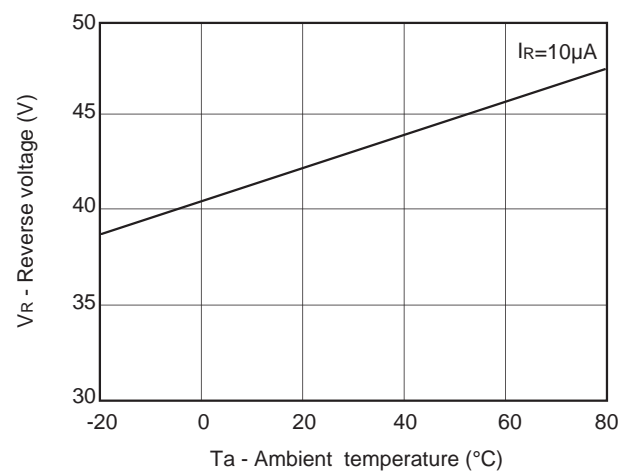

Diode capacitance vs. Ambient temperature

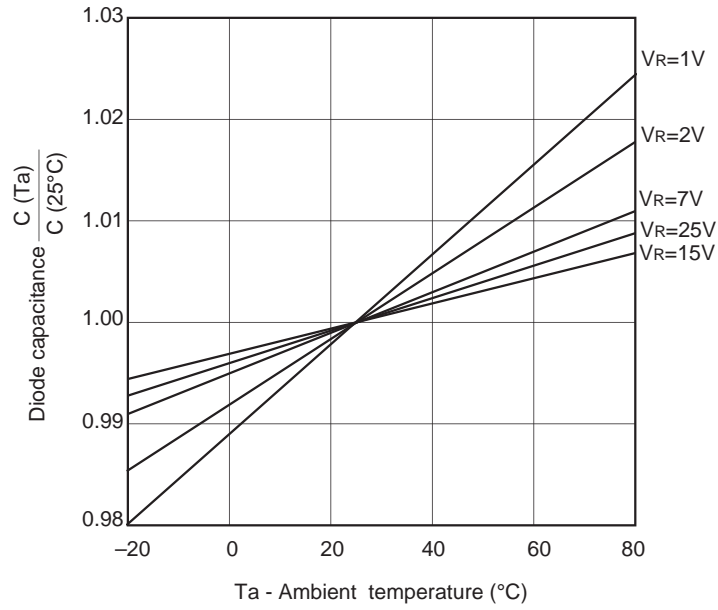

Reverse current vs. Reverse voltage

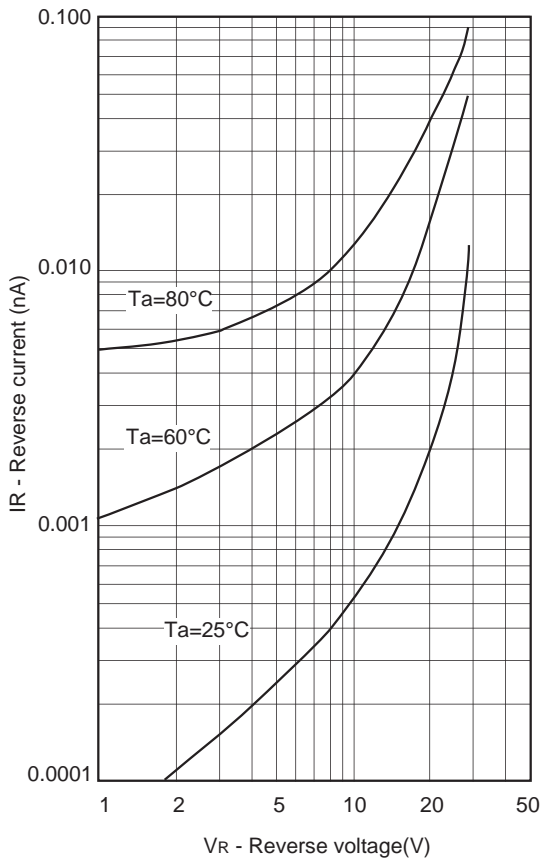

Thermal coefficient of diode capacitance vs. Reverse voltage

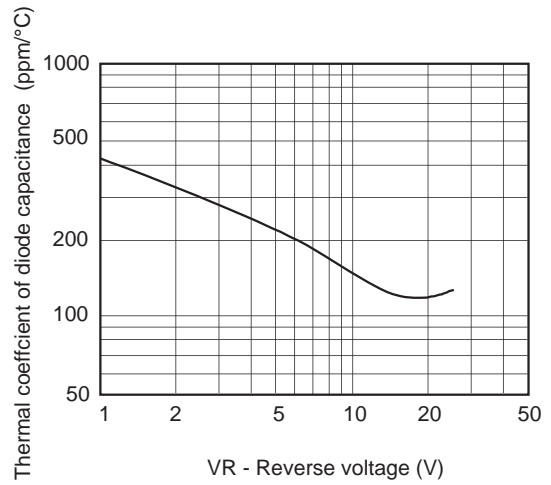

Package Outline Unit : mm

M-235

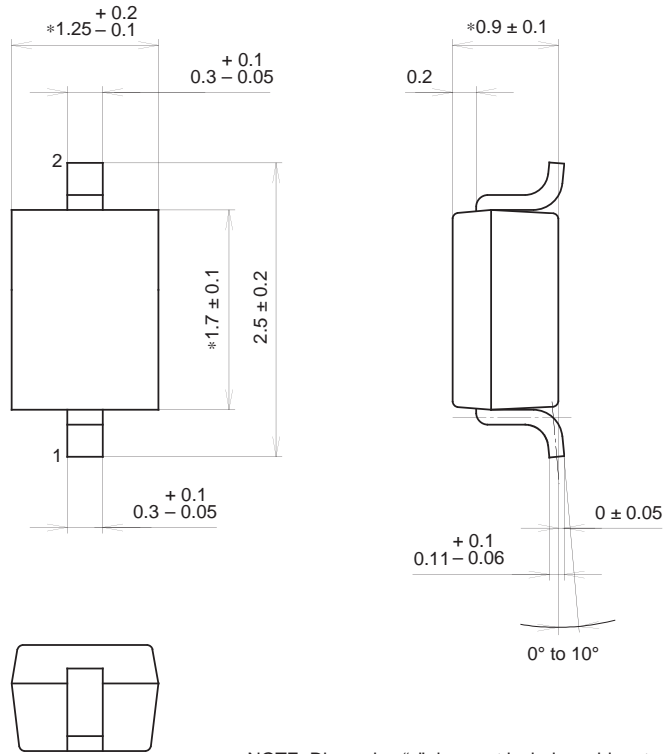

NOTE: Dimension "*" does not include mold protrusion.

SONY CODE	M-235
EIAJ CODE	_____
JEDEC CODE	_____

PACKAGE WEIGHT	0.1g
----------------	------

Marking

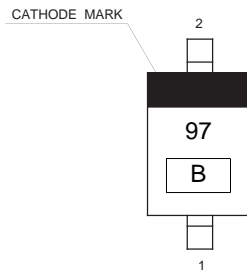

Notes

- 1) B: Lot No. (Year and Month of manufacture)
 Year; Last one digit
 Month; A, B, C (for Oct. to Dec.)
 1 to 9 (for Jan. to Sept.)



LittleDiode supplies new, hard to find or obsolete electronic components and semiconductors all over the world.

With over two million different components listed you are sure to find the part you need.

Feel free to visit us today at our online store:

LittleDiode.com

Looking forward to providing you with the best possible service.