

INTRODUCTION

The KA2295/Q is a monolithic integrated circuit designed for DTS music centers. It includes AM/FM IF AMP, FM Quad DET, AM, DET, and MPX functions.

FEATURES

- Wide operating supply voltage ($V_{CC} = 6V \sim 12V$)
- Low distortion (AM: 0.5%, FM: 0.3%)
- Non-Adjusting VCO: Non-Adjusting of free running frequency
- Built-in AM Band selection circuit
- Built-in VCO stop circuit and muting circuit
- Built-in AM/FM station detector circuit
- Suitable for DTS (Digital Tuning System) Music Centers

48-QFP-1010D/1010E

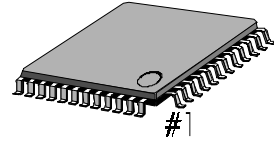

ORDERING INFORMATION

Device	Package	Operating Temperature	Pitch
KA2295	48-QFP-1010E	- 20°C ~ + 70°C	0.8mm
KA2295Q	48-QFP-1010D		0.75mm

BLOCK DIAGRAM

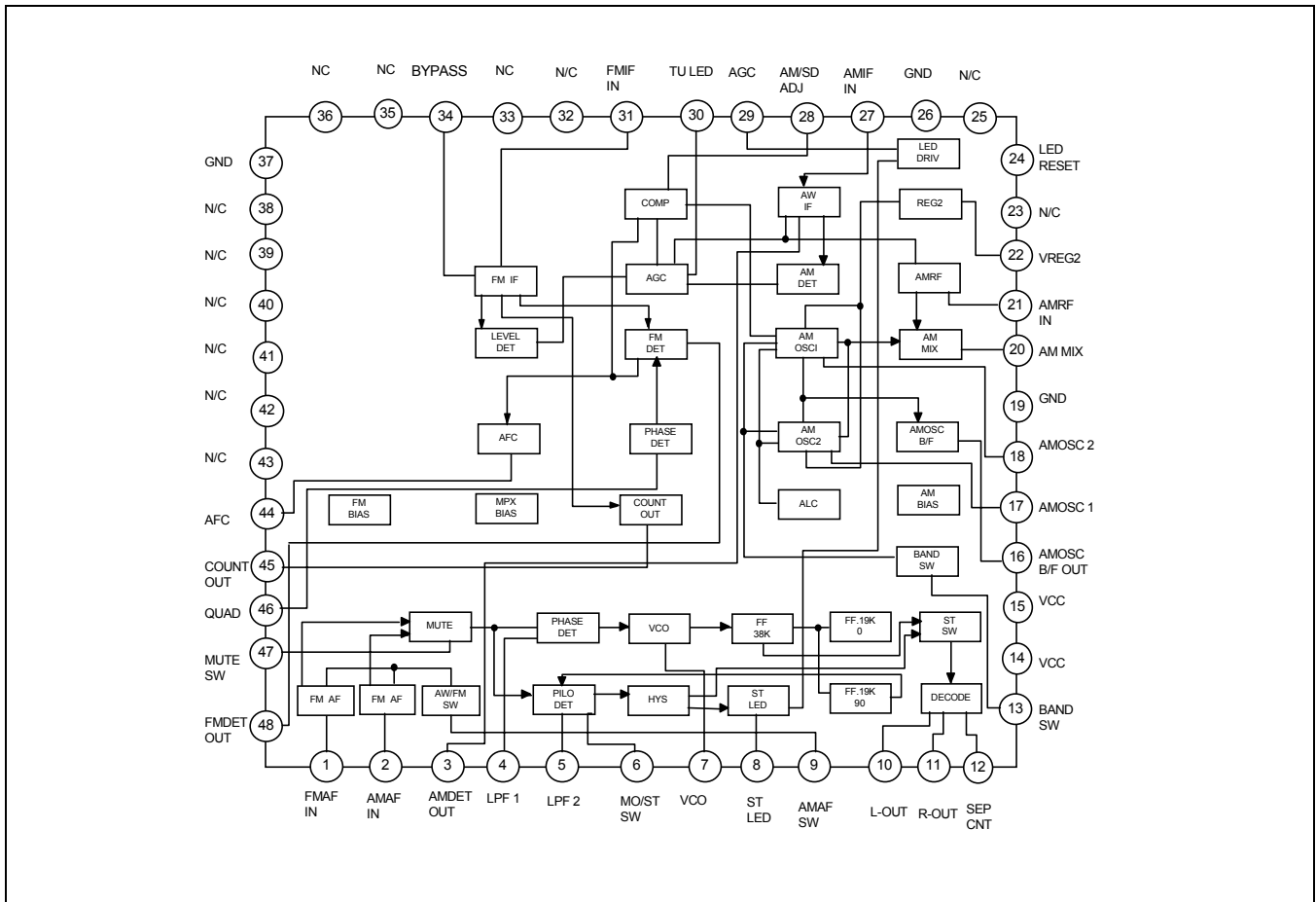

Figure 1.

PIN DESCRIPTION

Pin No	Name	I/O	Description
1	FM AF	I	FM AF input pin
2	AM AF	I	AM AF input pin
3	AM DET	O	AM DET output pin
4	LPF1	O	PHASE Detector output pin
5	LPF2	O	PILOT Detector output pin
6	MO/ST SW	–	Mono/stereo select pin
7	VCO	O	Voltage controlled oscillator pin
8	ST-LED	O	Stereo LED pin
9	AM/FM SW	–	AM/FM select pin
10	L-OUT	O	MPX L-channel output pin
11	R-OUT	O	MPX R-channel output pin
12	SEP CNT	–	Separation control pin
13	BAND SW	–	AM band select pin
14, 15	VCC	–	V _{CC} pin
16	BUFF OUT	O	AM OSC buffer output pin
17	AM OSC 1	O	AM OSC1 output pin
18	AM OSC 2	O	AM OSC2 output pin
19, 26, 37	GND	–	Ground pin
20	AM MIX	O	AM mixer output pin
21	AM RF	I	AM RF input pin
22	REG	I	Regulator pin
23, 25	N/C	–	Not used
24	LED SW	–	LED reset pin
27	AM IF	I	AM IF input pin
28	AM SD	O	AM station detector control pin
29	TU-LED	O	Tuning LED pin
30	AGC	O	AM AGC pin
31	FM IF	I	FM IF input pin
32, 33	NC	–	Not used
34	BY-PASS	O	FM IF bypass pin
35-43	NC	–	Not used
37	GND	–	FM IF ground
44	AFC	O	AGC output pin
45	COUNT	O	AM/FM IF count output pin
46	QUAD	O	FM quadrature detector pin
47	MUTE	–	Muting pin
48	FM DET	O	FM detector output pin

ABSOLUTE MAXIMUM RATINGS (Ta = 25°C)

Characteristic	Symbol	Value	Unit
Supply Voltage	V _{CC}	12	V
Power Dissipation	P _D	450	mW
Operating Temperature	T _{OPR}	-20 ~ 70	°C
Storage Temperature	T _{STG}	-40 ~ 120	-

ELECTRICAL CHARACTERISTICS

Characteristic	Symbol	Test Conditions	Min.	Typ.	Max.	Unit
*FM MONO (f_C = 10.7MHz, f_m = 1kHz, f = 75kHz, V_{CC} = 8.5V)						
Circuit Current 1	I _{CC1}	V _I = 0V	18	28	38	mA
-3 dB Sensitivity	V _{I(LIM)}	V _O = -3 dB DOWN	-	34	40	dBμ
Output Voltage 2	V _{OF2}	V _I = 100dBμ	450	550	670	mV
S/N Ratio 3	S/N F ₃	V _I = 100dBμ	72	77	-	dB
AM Rejection Ratio	AMR	V _I =100dBμ, MOD=30% AM, f _m = 1kHz	48	60	-	dB
T. H. D.	THD1	V _I = 100dBμ	-	0.2	1	%
IF Buffer Output 1	V _{OIF1}	V _I = 50dBμ	5	260	350	mVrms
LED On Sensitivity	V _{L(ON)1}	V _I = variable, svr = 27kΩ	42	52	62	dBμ
*FM STEREO (f_C = 10.7MHz, f = 75kHz, L + R = 90%, PILOT = 10%, V_I = 100dBμ, V_{CC} = 8.5V)						
Separation	SEP	f _m = 1kHz, Stereo	35	45	-	dB
T. H. D.	THD ST	f _m = 1kHz	-	0.3	1	%
LED On Level	V _(ON)	Pilot only	4	10	16	mV
Hysteresis	HY	Pilot only	1	3	6	dB
Channel Balance	CB	V _I = 300mV (Mono)	-1	0	+1	dB
Muting Attenuation	ATT	V _I - 300mV (Mono)	67	82	-	dB
*AM (f_C = 1MHz, f_m = 1kHz, MOD = 30%)						
Circuit Current 3	I _{CCA3}	V _I = 0V	17	27	37	mA
Output Voltage 2	V _{O A2}	V _I = 27dBμ	70	140	260	mV
Output Voltage 1	V _{O A1}	V _I = 80dBμ	170	280	390	mV
T. H. D. 1	THD A ₁	V _I = 80dBμ	-	0.5	1.2	%
T. H. D. 2	THD A ₂	V _I = 100dBμ	-	0.6	1.3	%
OSC. Voltage 1	OSC 1	V _I = 0V	150	250	350	mVrms
OSC. Voltage 2	OSC 2	V _I = 0V	150	250	350	mVrms
S/N Ratio 2	S/N 2	V _I = 23dBμ	10	13	-	dB
S/N Ratio 1	S/N A ₂	V _I = 80dBμ	44	50	-	dB
If Buffer Output 2	V _{(IF)A1}	V _I = 20dBμ	70	100	200	dB
Led On Sensitivity2	V _{L(ON)2}	V _I = variable, SVR = 10kΩ	-	13	20	dBμ

COIL SPECIFICATION

NO	FUNCTION	f _o	Q	L	C	TURNS					NOTES
						1-2	1-3	2-3	2-4	4-6	
T1	MW OSC	1.45 MHz	140	140 uH	–	–	64	–	–	32	–
T2	LW OSC	670 kHz	130	220 uH	–	–	80	–	–	40	–
T2	SW OSC	–	28	1.3 uH	–	–	12	–	–	8	–
T3	AM IFT	450 kHz	–	–	180 pF	94	–	58	–	7	–
T4	FM DET	10.7MHz	95	–	56 pF	–	12	–	–		–

OPERATING PRINCIPLES & METHODS

AM band oscillator

We use new band selection techniques in this IC.

This band selection block is composed of 5 blocks: ALC, OSC1, OSC2, buffer, and select switch. So each microm voltage (high or low) can select the AM bands (mw or lw or sw).

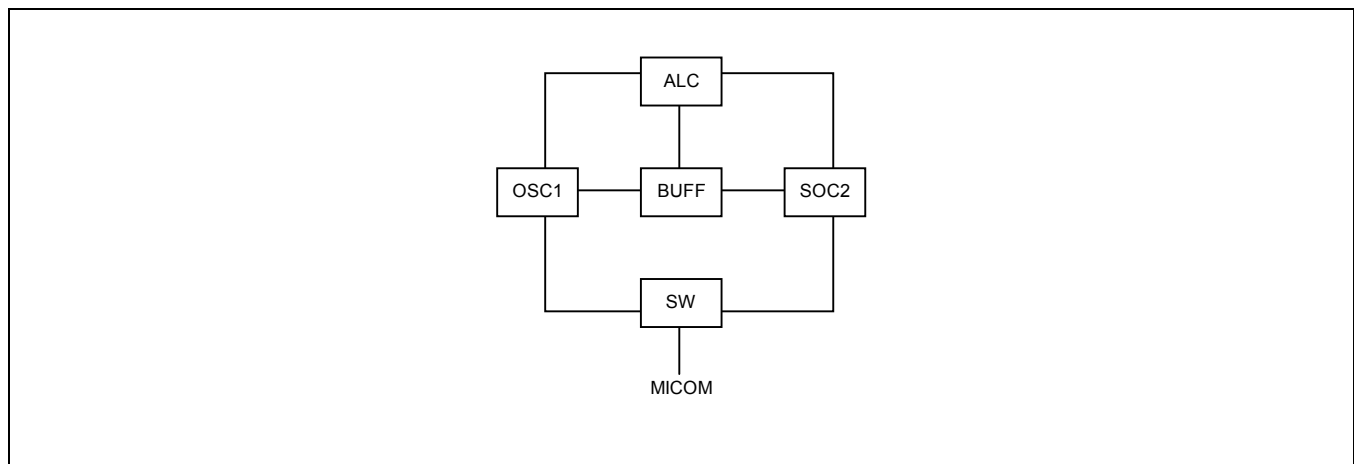

Figure 3.

Mono, stereo select switch

In FM mode, we can select mono or stereo with microm output voltage, and in stereo state, we can change the state into mono by compulsion.

Vmicom	STATE	Q1	Q2	VA
HIGH	MONO	SAT	SAT	2.4V
LOW	STEREO	OFF	OFF	8.5V

NOTE: "SAT" means saturation.

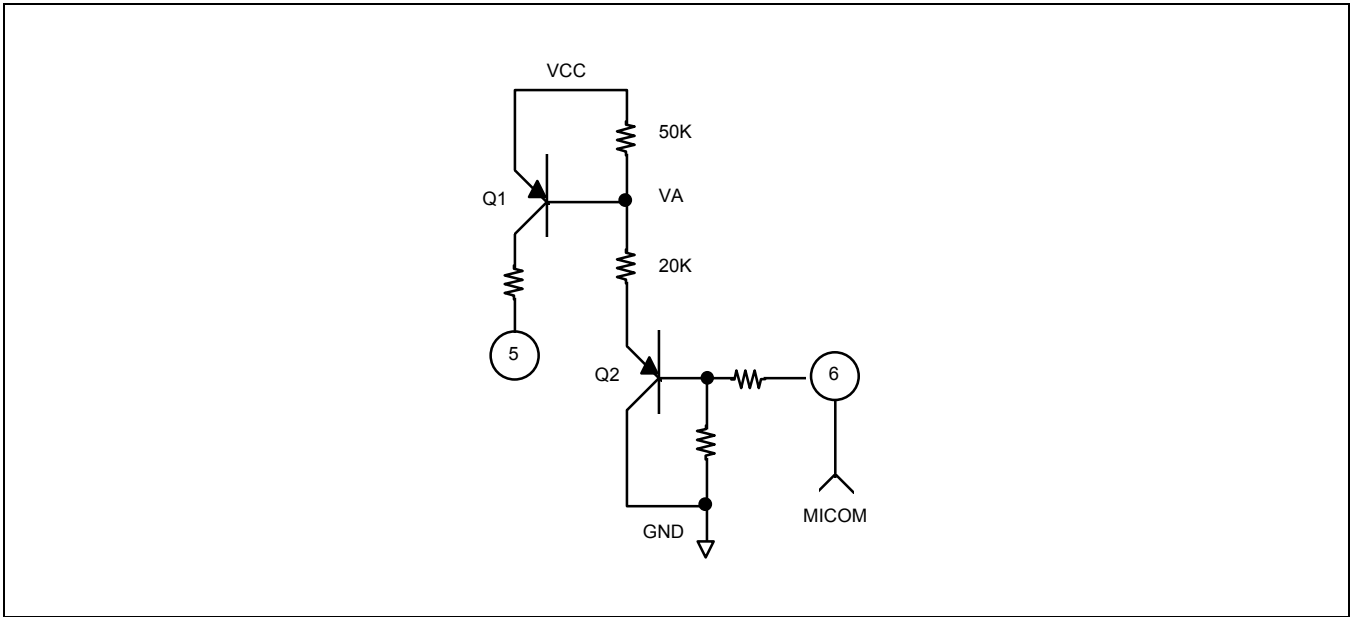

Figure 4.

APPLICATION CIRCUIT

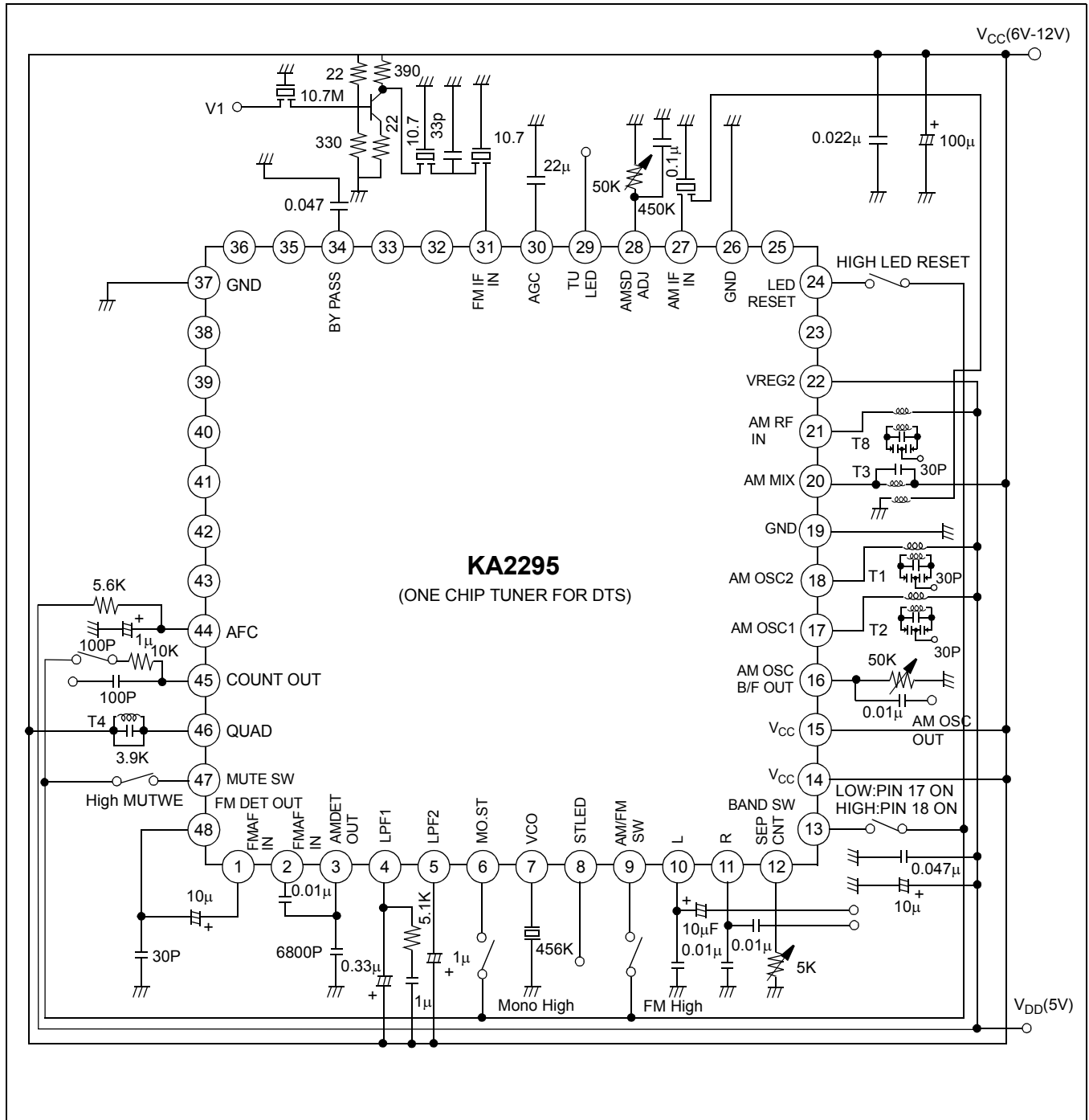

Figure 5.



LittleDiode supplies new, hard to find or obsolete electronic components and semiconductors all over the world.

With over two million different components listed you are sure to find the part you need.

Feel free to visit us today at our online store:

LittleDiode.com

Looking forward to providing you with the best possible service.