

GP1A70R/GP1A71R

OPIC Photointerrupter with Encoder Functions

■ Features

1. 2-phase (A, B) digital output
2. Sensing accuracy
(**GP1A70R** Disk slit pitch : 1.14mm)
(**GP1A71R** Disk slit pitch : 0.7mm)
3. PWB mounting type
(Lead bending type)
4. TTL compatible output
5. Compact, lightweight

■ Applications

1. Printers
2. Copiers
3. Numerical control machines

■ Outline Dimensions

(Unit : mm)

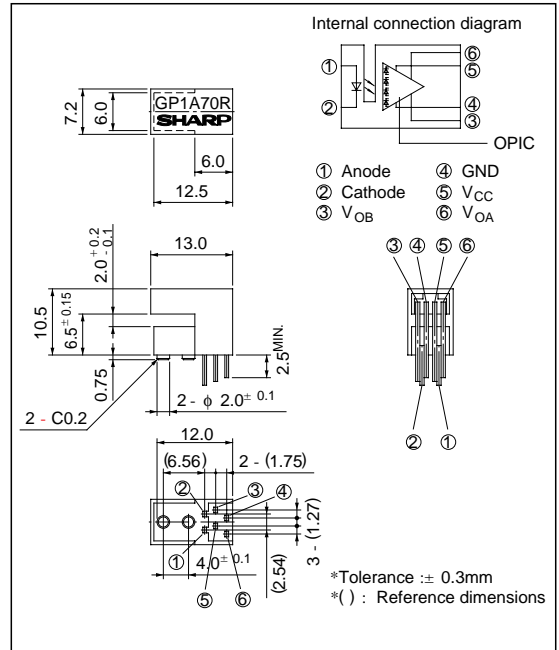

**"OPIC" (Optical IC) is a trademark of the SHARP Corporation.
An OPIC consists of a light-detecting element and signal-processing circuit integrated onto a single chip.

■ Absolute Maximum Ratings

(T_a = 25°C)

	Parameter	Symbol	Rating	Unit
Input	Forward current	I _F	50	mA
	^{*1} Peak forward current	I _{FM}	1	A
	Reverse voltage	V _R	6	V
	Power dissipation	P	75	mW
Output	Supply voltage	V _{CC}	7	V
	Low level output current	I _{OL}	20	mA
	Power dissipation	P _O	250	mW
	Operating temperature	T _{opr}	0 to + 70	°C
	Storage temperature	T _{stg}	- 40 to + 80	°C
	^{*2} Soldering temperature	T _{sol}	260	°C

*1 Pulse width ≤ 100μs, Duty ratio 0.01

*2 For 5 seconds

Electro-optical Characteristics

(Ta = 25°C unless otherwise specified)

Parameter		Symbol	Conditions	MIN.	TYP.	MAX.	Unit
Input	Forward voltage	V_F	$I_F = 20\text{mA}, T_a = 25^\circ\text{C}$	-	1.2	1.4	V
	Reverse current	I_R	$V_R = 3\text{V}, T_a = 25^\circ\text{C}$	-	-	10	μA
Output	Operating supply voltage	V_{CC}		4.5	5.0	5.5	V
	High level output voltage	V_{OH}	^{*3} $V_{CC} = 5\text{V}, I_F = 20\text{mA}$	2.4	4.9	-	V
	Low level output voltage	V_{OL}	^{*3} $I_{OL} = 8\text{mA}, V_{CC} = 5\text{V}, I_F = 20\text{mA}$	-	0.1	0.4	V
	Supply current	I_{CC}	^{*4} $V_{CC} = 5\text{V}, I_F = 20\text{mA}$	-	5	20	mA
	Duty ratio	GP1A70R GP1A71R	^{*5} D_A, D_B	^{*3} $V_{CC} = 5\text{V}, I_F = 20\text{mA}, f = 2.5\text{kHz}$	25	50	75
Transfer characteristics	Response frequency	$f_{MAX.}$	^{*3} $V_{CC} = 5\text{V}, I_F = 20\text{mA}$	-	-	10	kHz

*3 Measured under the condition shown in Measurement Conditions.

*4 In the condition that output A and B are low level.

*5 $D_A: \frac{t_{AH}}{t_{AP}} \times 100, D_B: \frac{t_{BH}}{t_{BP}} \times 100$, Duty ratio: Average disk rotation time per turn

Output Waveforms

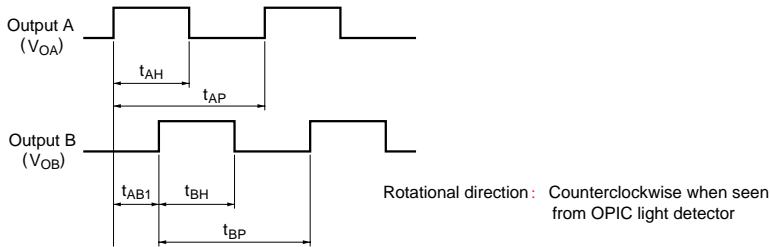

Fig. 1 Forward Current vs. Ambient Temperature

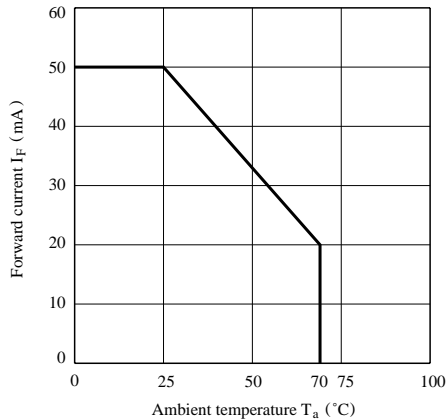

Fig. 2 Output Power Dissipation vs. Ambient Temperature

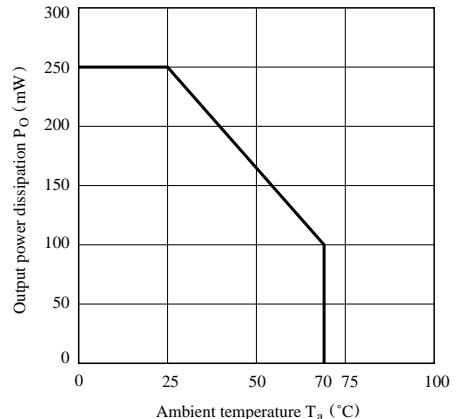

Fig. 3-a Duty Ratio vs. Frequency (GP1A70R)

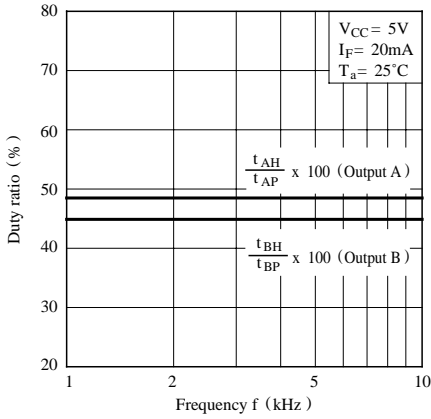

Fig. 3-b Duty Ratio vs. Frequency (GP1A71R)

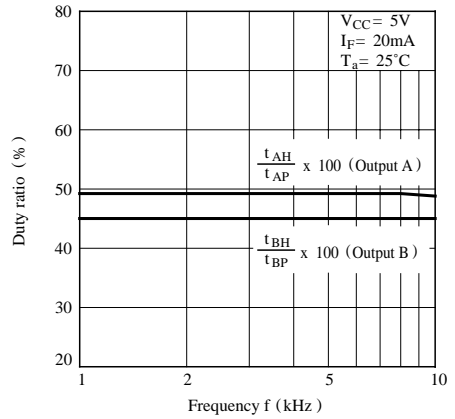

Fig. 4-a Phase Difference vs. Frequency (GP1A70R)

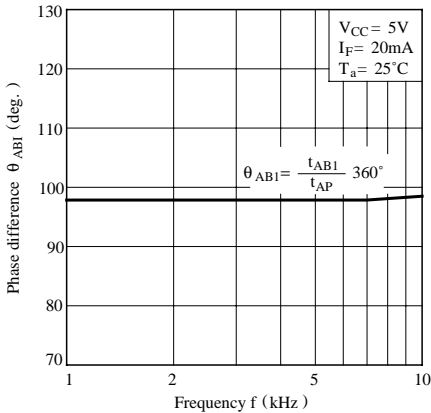

Fig. 4-b Phase Difference vs. Frequency (GP1A71R)

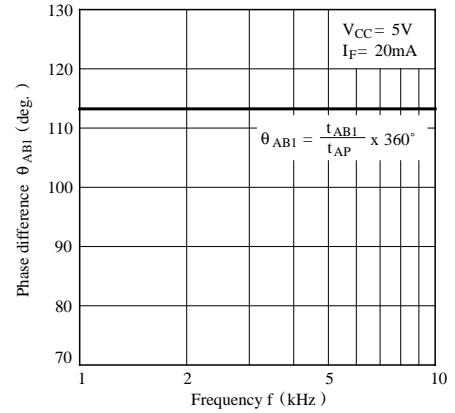

Fig. 5-a Duty Ratio vs. Ambient Temperature (GP1A70R)

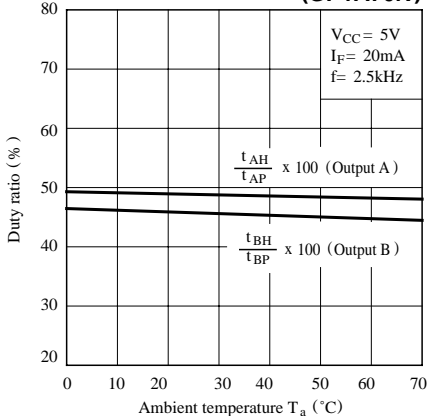

Fig. 5-b Duty Ratio vs. Ambient Temperature (GP1A71R)

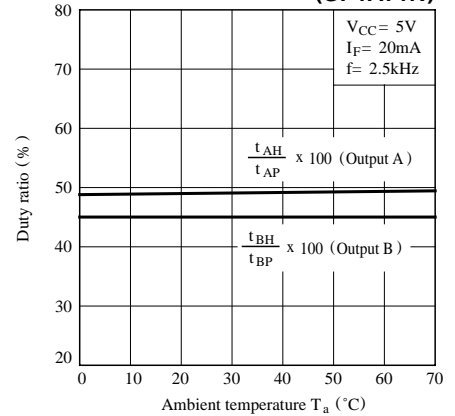

Fig. 6-a Phase Difference vs. Ambient Temperature

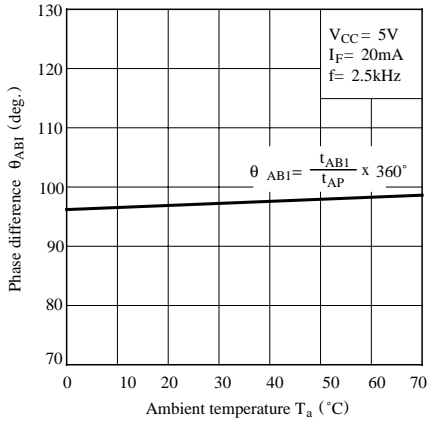

Fig. 6-b Phase Difference vs. Ambient Temperature

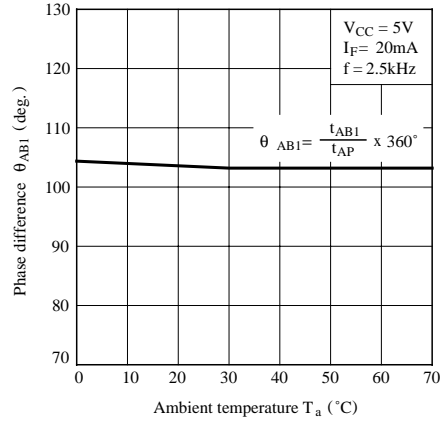

Fig. 7-a Duty Ratio vs. Distance (Xdirection)

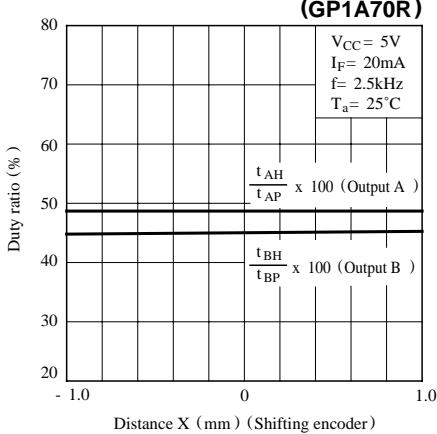

Fig. 7-b Duty Ratio vs. Distance (X direction)

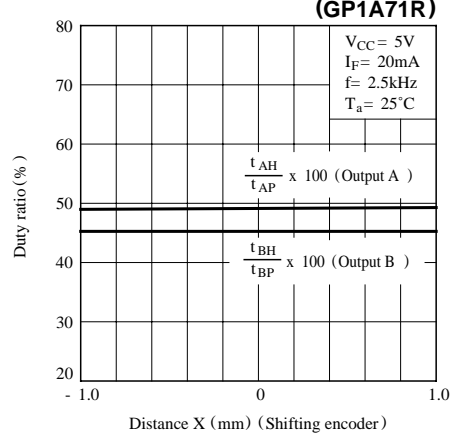

Fig. 8-a Phase Difference vs. Distance (X direction)

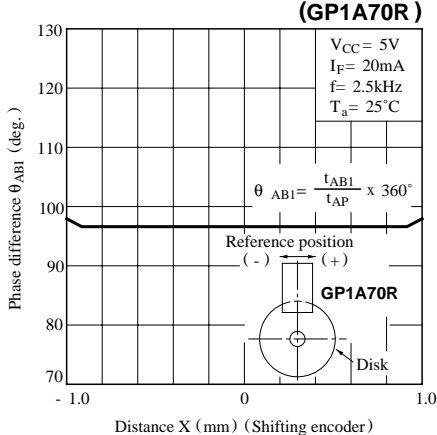

Fig. 8-b Phase Difference vs. Distance (X direction)

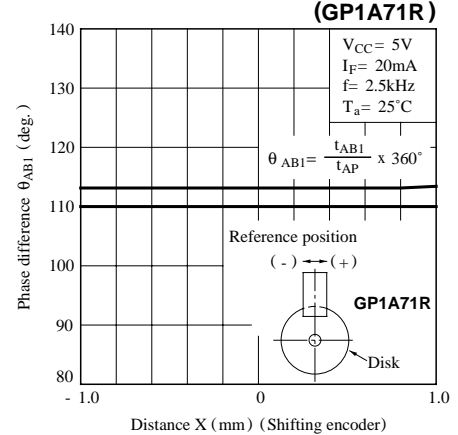

Fig. 9-a Duty Ratio vs. Distance (Ydirection) (GP1A70R)

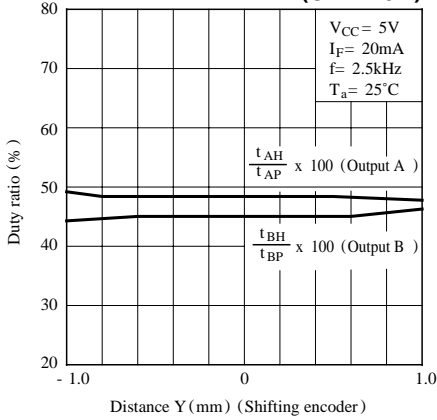

Fig. 9-b Duty Ratio vs. Distance (Y direction) (GP1A71R)

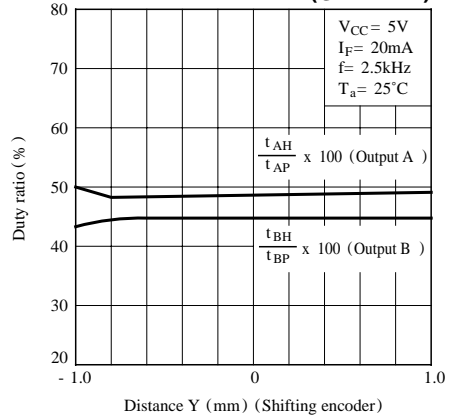

Fig.10-a Phase Difference vs. Distance (Y direction) (GP1A70R)

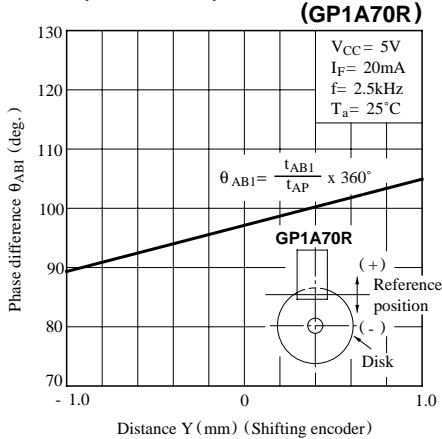

Fig.10-b Phase Difference vs. Distance (Y direction) (GP1A71R)

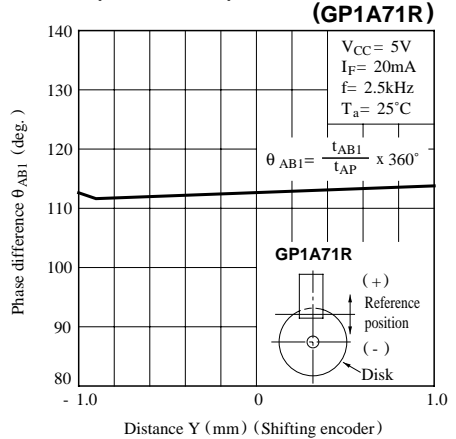

Fig.11-a Duty Ratio vs. Distance (Z direction) (GP1A70R)

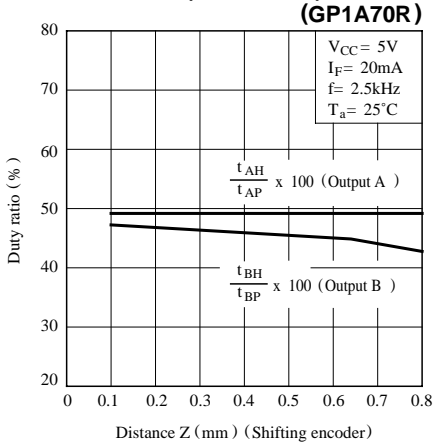

Fig.11-b Duty Ratio vs. Distance (Z direction) (GP1A71R)

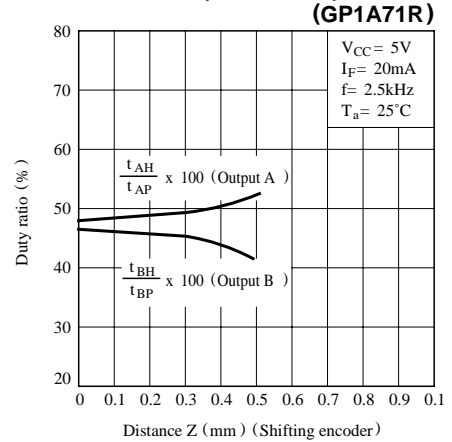

Fig.12-a Phase Difference vs. Distance
(Z direction)

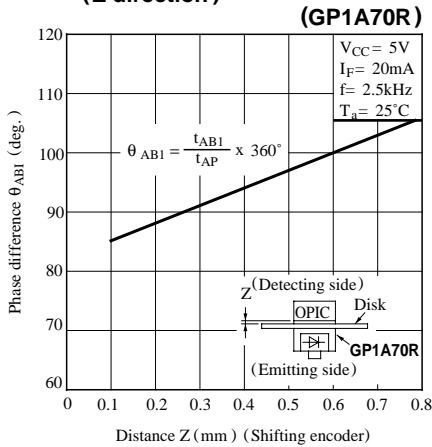
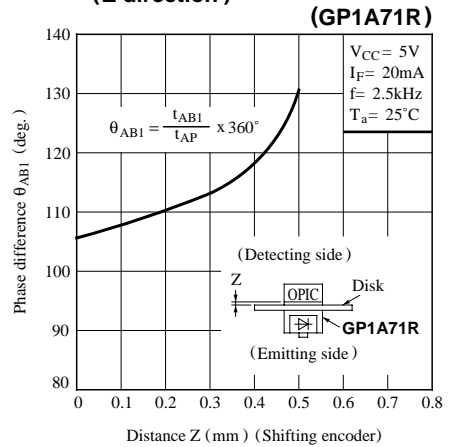
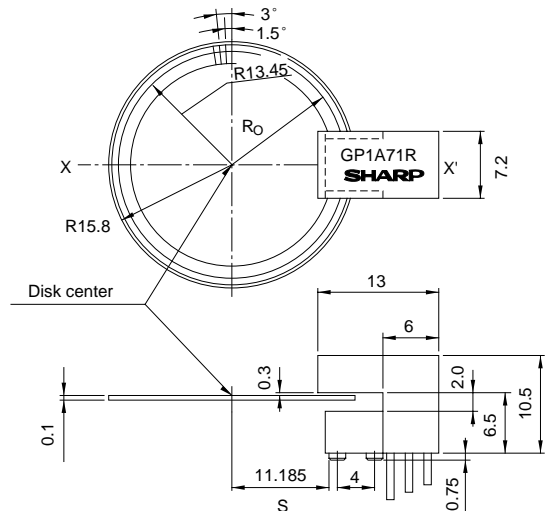
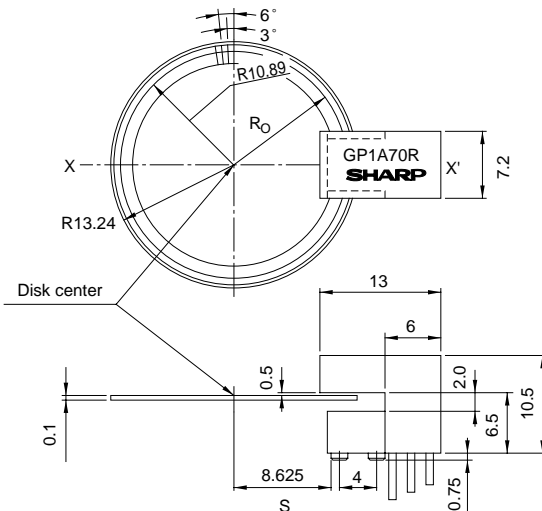

Fig.12-b Phase Difference vs. Distance
(Z direction)



<Measurement Conditions> (Unit : mm)



<GP1A70R Basic Design>

R_0 (distance between the disk center and half point of a slit) and S (installing position of GP1A70R) will be provided by the following equations.

$$R_0 = N/60 \times 10.89 \text{ (mm)} \quad N: \text{ number of slits}$$

$$S = R_0 - 2.265 \text{ (mm)}$$

<GP1A71R Basic Design>

R_0 (distance between the disk center and half point of a slit) and S (installing position of GP1A71R) will be provided by the following equations.

$$R_0 = N/120 \times 13.45 \text{ (mm)} \quad N: \text{ number of slits}$$

$$S = R_0 - 2.265 \text{ (mm)}$$

■ Precautions for Use

- (1) This device is designed to be used under the condition of $I_F = 20mA$
- (2) It is recommended that a by-pass capacitor of more than $0.01\mu F$ be added between V_{CC} and GND near the device in order to stabilize power supply line.
- (3) As for other general cautions, refer to the chapter "Precautions for Use".



LittleDiode supplies new, hard to find or obsolete electronic components and semiconductors all over the world.

With over two million different components listed you are sure to find the part you need.

Feel free to visit us today at our online store:

LittleDiode.com

Looking forward to providing you with the best possible service.