

Infrared IrDA Compliant Transceiver

Technical Data

Features

- Fully Compliant to IrDA 1.0 – 115 Kb/s
- Compatible with ASK, Consumer IR/TV Remote
- Superb Nose-to-Nose Operation
- Low Power Consumption 3 μ A in Shutdown
- Supply Voltage Range 2.7 V – 5.5 V
- Operational Down to 2 V
- Free Netlist for IrDA Modulation Circuitry
- Low Latency 100 μ s
- Available in Tape & Reel for Auto Insertion
- Drop in Replacement for HSDL-1000

Description

The HSDL-1001 infrared transceiver provides the interface between logic and IR signals for through-air, serial, half-duplex IR data links and is designed to satisfy the IrDA Physical Layer Specification for data rates up to 115 Kb/s.

The HSDL-1001 contains a high speed, high efficiency TS AlGaAs 875 nm LED, a silicon PIN photodiode and a bipolar, silicon

HSDL-1001

integrated circuit. The IC contains an LED driver, amplifiers and a quantizer.

The shutdown function permits operating the receiver in a low current mode to minimize battery drain.

Applications for the HSDL-1001 include notebook PCs, telephones, pagers, printers, cameras, and industrial handheld devices.

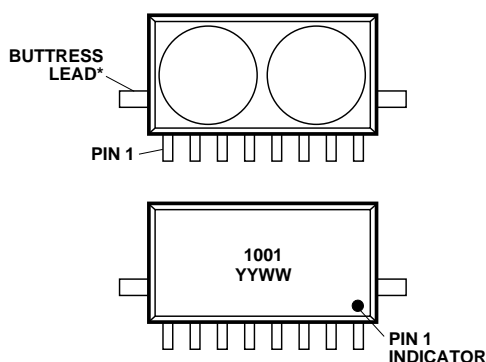

* SIDE BUTTRESS LEADS ARE FOR MECHANICAL STABILITY AND SHOULD NOT BE CONNECTED TO ANY ELECTRICAL POTENTIAL.

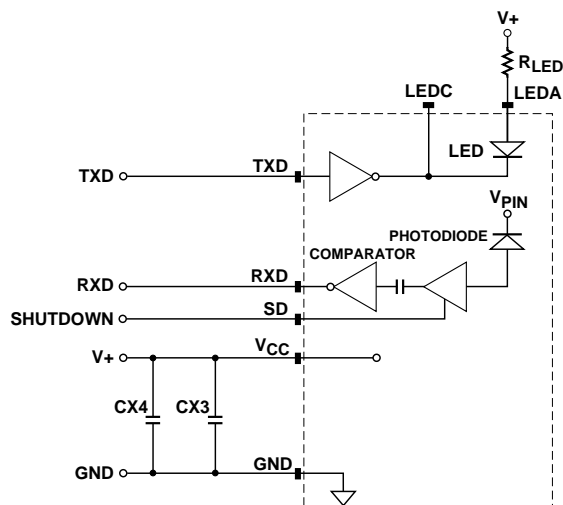

Package Dimensions

Option 0X1*

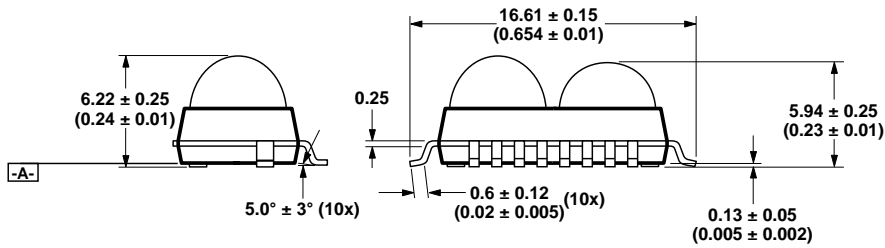
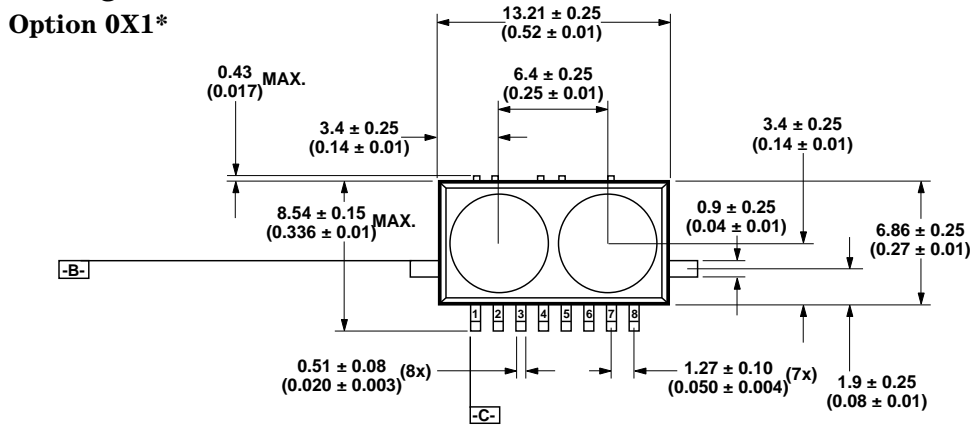

DIMENSIONS IN MILLIMETERS (INCHES).

Option 0X2*

NOTE:
THE -B- DATUM IS FORMED BY THE TWO HIGHEST POINTS OF THE COMBINED SURFACE FORMED BY THIS SURFACE AND THE CORRESPONDING SURFACE OF THE SAME LEAD ON THE OPPOSITE SIDE OF THE PACKAGE.

0 = TAPE AND REEL.

X = STRIP OF 10.

1 = JEDEC STANDARD ARRAY.

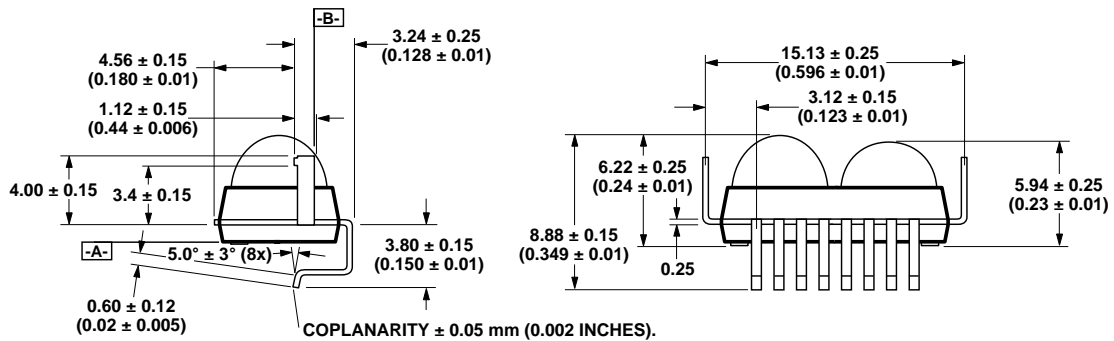
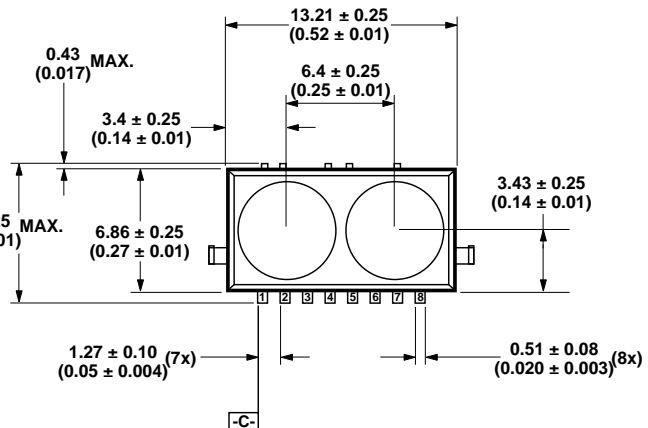

DIMENSIONS IN MILLIMETERS (INCHES).

Package Dimensions (continued)

Option X04

NOTE:
THE -B- DATUM IS FORMED BY THE TWO HIGHEST POINTS OF THE COMBINED SURFACE FORMED BY THIS SURFACE AND THE CORRESPONDING SURFACE OF THE SAME LEAD ON THE OPPOSITE SIDE OF THE PACKAGE.

*X POSITION INDICATES PACKAGING.
0 = TAPE AND REEL.
1 = JEDEC STANDARD ARRAY.

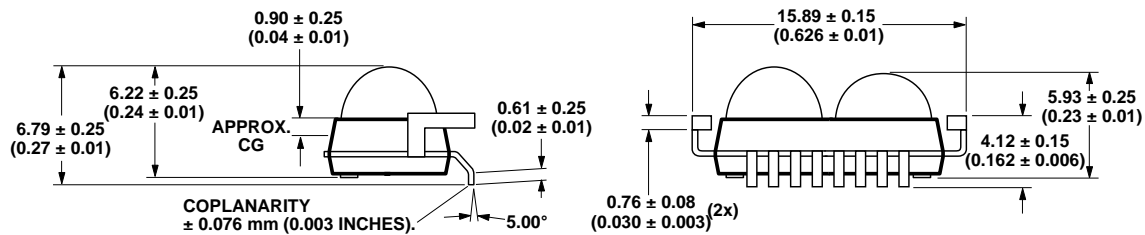
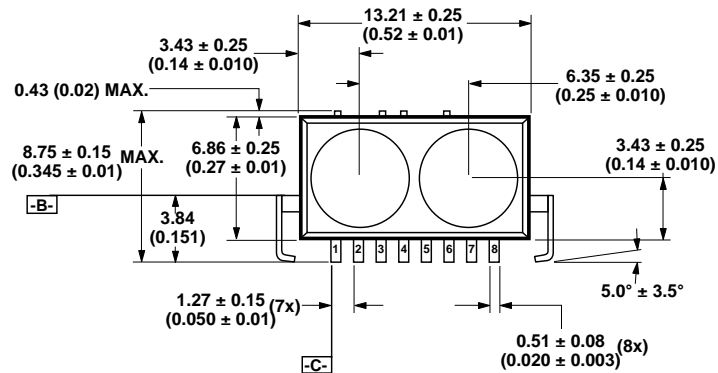

DIMENSIONS IN MILLIMETERS (INCHES).

Truth Table

| Inputs | | | Outputs | | |
|-----------------|---------------------------------|-----------------|-----------|------|--------------------|
| TXD | EI ^[1] | SD | IE(LED) | LEDA | RXD |
| V _{IH} | X | X | High (On) | Low | NV |
| V _{IL} | EI _{IH} ^[2] | V _{IL} | Low (Off) | High | Low ^[3] |
| V _{IL} | EI _{IL} | V _{IL} | Low (Off) | High | High |
| V _{IL} | X | V _{IH} | Low (Off) | High | High |

X = Don't care

NV = Not Valid

Notes:

- EI – Irradiance (light intensity) present at detector surface.
- For in-band IrDA signals ≤ 115 kb/s.
- RXD Low is a pulsed response. The condition is maintained for a duration dependent on the pattern and strength of the incident signal.

Pinout

| Pin | Description | Symbol |
|-----|------------------------|-----------------|
| 1 | Shutdown | SD |
| 2 | No Connection | |
| 3 | Supply Voltage | V _{CC} |
| 4 | Receiver Data Output | RXD |
| 5 | Ground | Gnd |
| 6 | Transmitter Data Input | TXD |
| 7 | LED Cathode | LEDC |
| 8 | LED Anode | LEDA |

Absolute Maximum Ratings

| Parameter | Symbol | Min. | Max. | Units | Conditions |
|--------------------------------|-----------------------|------|------------------------------|-------|--|
| Storage Temperature | T _S | -20 | 85 | °C | |
| Operating Temperature | T _A | 0 | 70 | °C | |
| Lead Solder Temperature | | | 260 | °C | For 10 s (1.6mm below seating plane) |
| Average LED Current | I _{LED} (DC) | | 100 | mA | |
| Repetitive Pulsed LED Current | I _{LED} (RP) | | 500 | mA | ≤ 90 μs Pulse Width, ≤ 20% Duty Cycle |
| Peak LED Current | I _{LED} (PK) | | 1.0 | A | ≤ 2 μs Pulse Width, ≤ 10% Duty Cycle |
| LED Anode Voltage | V _{LEDA} | -0.5 | 7.0 | V | |
| LED Cathode Voltage | V _{LEDC} | -0.5 | V _{LEDA} | V | |
| Supply Voltage | V _{CC} | 0 | 7.0 | V | |
| Transmitter Data Input Voltage | V _{TXD} | -0.5 | V _{CC} , 5.5 | V | |
| Receiver Data Output Voltage | V _{RXD} | -0.5 | (V _{CC} + 0.5), 5.5 | V | |
| Shutdown | V _{SD} | -0.5 | V _{CC} , 5.5 | V | |

Recommended Operating Conditions

| Parameter | Symbol | Min. | Max. | Units | Conditions |
|--|---------------|--------|----------|--------------------|--|
| Operating Temperature | T_A | 0 | 70 | °C | |
| Supply Voltage | V_{CC} | 2.7 | 5.5 | V | |
| Logic High Transmitter Input Voltage | $V_{IH}(TXD)$ | 2.5 | V_{CC} | V | |
| Logic Low Transmitter Input Voltage | $V_{IL}(TXD)$ | 0.0 | 0.8 | V | |
| Logic Low Shutdown Input Voltage | $V_{IL}(SD)$ | 0.0 | 0.8 | V | |
| Logic High Shutdown Input Voltage | $V_{IH}(SD)$ | 2.5 | V_{CC} | V | |
| Logic High Receiver Input Irradiance | E_{IH} | 0.0036 | 500 | mW/cm ² | For in-band signals* |
| Logic Low Receiver Input Irradiance | E_{IL} | | 0.3 | μW/cm ² | For in-band signals* |
| LED (Logic High) Current Pulse Amplitude | I_{LEDA} | 240 | | mA | For one metre links with daylight filters |
| Receiver Set-up Time | | 200 | | μs | For full sensitivity after transmitting |
| Signal Rate RXD | | 2.4 | 115 | Kp/s | |
| Ambient Light | | | | | See IrDA Serial Infrared Physical Layer Link Specification, Appendix A for ambient levels. |

***Note:** An in-band optical signal is a pulse/sequence where the peak wavelength, λ_p , is defined as $850 \text{ nm} \leq \lambda_p \leq 900 \text{ nm}$, the pulse repetition rate, PRR, is defined as $2.4 \text{ Kp/s} \leq \text{PRR} \leq 115.2 \text{ Kp/s}$ and the pulse width, PW, is defined as $1.6 \text{ μs} \leq \text{PW} \leq (3/16)/\text{PRR}$.

Electrical & Optical Specifications

Specifications hold over $3.0\text{ V} \leq V_{CC} \leq 5.5\text{ V}$ and $0^\circ\text{C} \leq T_A \leq 70^\circ\text{C}$ and all typicals are at $V_{CC} = 5.0\text{ V}$ and $T_A = 25^\circ\text{C}$ unless otherwise specified. Listed conditions represent worst case values for the parameters under test. Unspecified test conditions can be anywhere in their recommended operating range.

| Parameter | | Symbol | Min. | Typ. | Max. | Unit | Conditions |
|--------------------------------------|--------------------------|------------------------------|--------------|------------|------------|--------------------------------|---|
| Receiver Data Output Voltage | Logic Low ^[2] | $V_{OL}(\text{RXD})^{[1,2]}$ | | | 0.4 | V | For in-band EI $\geq 3.6\ \mu\text{W}/\text{cm}^2$, $\phi^{1/2} \leq 15^\circ$ |
| | Logic High | $V_{OH}(\text{RXD})$ | $V_{CC}-0.6$ | | | V | $I_o = -20\ \mu\text{A}$, for in-band EI $\leq 0.3\ \mu\text{W}/\text{cm}^2$ |
| Receiver Field of View | Twice Half-Angle | $2\phi^{1/2}$ | 30 | | | ° | Half-angle, $\phi^{1/2}$, is the angle where receiver sensitivity = $3.6\ \mu\text{W}/\text{cm}^2$. |
| Receiver Peak Sensitivity Wavelength | | $\lambda_p(\text{EI})$ | | 880 | | nm | |
| Effective Detector Area | | | | 0.16 | | cm^2 | |
| Transmitter Radiant Intensity | Logic High Intensity | IEH | 55 44 | 109 | 250 | mW/SR mW/SR | $I_{LEDA} = 240\ \text{mA}$, $V_I = 2.5\ \text{V}$ $T_A = 25^\circ\text{C}$ $0^\circ\text{C} \leq T_A \leq 70^\circ\text{C}$ |
| | Peak Wavelength | $\lambda_p(\text{IE})$ | | 875 | | nm | |
| | Spectral Line Half Width | $\Delta\lambda^{1/2}$ | | 35 | | nm | |
| Transmitter Field of Emission | Twice Half-Angle | $2\theta^{1/2}$ | 30 | | 60 | ° | Half-angle, $\theta^{1/2}$, is the angle where radiant intensity = $44\ \text{mW}/\text{SR}$. |
| Transmitter Data Input Current | Logic Low | $I_{IL}(\text{TXD})$ | -1.0 | | 5.0 | μA | $0 \leq V_I \leq 0.8\ \text{V}$ |
| | Logic High | $I_{IH}(\text{TXD})$ | | 40 125 | 100 250 | μA μA | $V_I = 2.5\ \text{V}$ $V_I = 5.0\ \text{V}$ |
| LED Anode On State Voltage | | $V_{ON}(\text{LEDA})$ | | 2.1 | 2.50 | V | $I_{LEDA} = 240\ \text{mA}$, $T_j = 25^\circ\text{C}$ |
| LED Anode Off State Leakage | | $I_{LK}(\text{LEDA})$ | | <0.2 | 10 | μA | $V_{LEDA} = V_{CC} = 5.5\ \text{V}$, $V_I = 0.3\ \text{V}$ |
| Supply Current | Idle | I_{CC1} | | 190 210 | 260 290 | μA μA | $V_{CC} = 3.6\ \text{V}$ $V_{CC} = 5.5\ \text{V}$, EI = EI _{IL} , $V_I(\text{TXD}) = V_{IL}$ |
| | Active Receiver | I_{CC2} | | 0.22 | 25 | mA | $V_{CC} = 5.5\ \text{V}$, EI = EI _{IH} , $V_I(\text{TXD}) = V_{IL}$ |
| | Active Transmitter | I_{CC3} | | | 10 | mA | $V_{CC} = 5.5\ \text{V}$, EI = EI _{IL} , $V_I(\text{TXD}) = V_{IH}$ |
| | Shutdown | $I_{CC}(\text{SD})$ | | 3 5 | 14 20 | μA μA | $V_{CC} = 3.6\ \text{V}$ $V_{CC} = 5.5\ \text{V}$, EI = EI _{IL} , $V_I(\text{TXD}) = V_{IL}$, $V_{SD} = V_{IH}$ |
| Shutdown Input Current | Logic High | $I_{IH}(\text{SD})$ | | 2.5 | 10 | μA | $V_{CC} = 5.5\ \text{volts}$ $V_{SD} = 5.5\ \text{volts}$ |
| | | $I_{IH}(\text{SD})$ | | 2 | 8 | μA | $V_{CC} = 3.6\ \text{volts}$ $V_{SD} = 3.6\ \text{volts}$ |
| | Logic Low | $I_{IL}(\text{SD})$ | -1.0 | | 1 | μA | $3.0\ \text{V} \leq V_{CC} \leq 5.5\ \text{V}$ $0\ \text{V} \leq V_{SD} \leq 0.8\ \text{V}$ |

Notes:

- Pulsed Response — Logic Low is a pulsed response. A receiver output low state $V_{OL}(\text{RXD})$ is not indefinitely maintained but is instead a pulsed response. The output low state is maintained for a duration dependent on the incident bit pattern and incident intensity (EI).
- The $E_I \geq 3.6\ \mu\text{W}/\text{cm}^2$ condition guarantees the IrDA minimum receiver sensitivity of $4.0\ \mu\text{W}/\text{cm}^2$ while allowing for 10% light loss through a cosmetic window placed in front of the HSDL-1001.

Switching Specifications

Specifications hold over $3.0\text{ V} \leq V_{CC} \leq 5.5\text{ V}$ and $0 \leq T_A \leq 70^\circ\text{C}$ and all typicals are at $V_{CC} = 5.0\text{ V}$ and $T_A = 25^\circ\text{C}$ unless otherwise specified. Listed conditions represent worst case values for the parameters under test. Unspecified test conditions can be anywhere in their recommended operating range.

| Parameter | Symbol | Min. | Typ. | Max. | Units | Conditions |
|---------------------------------|---------------|------|------|------|---------------|---|
| Transmitter Optical Pulse Width | $t_{pw}(SD)$ | 1.45 | 1.7 | 2.15 | μs | $R_{LED} = \text{Recommended Value}$ $2.5\text{ V} \leq V_{IH}(TXD) \leq V_{CC}$ $t_{pw}(TXD) = 1.6\text{ }\mu\text{s}$ |
| Transmitter Optical Rise Time | $t_r(SD)$ | | 0.05 | 0.6 | μs | |
| Transmitter Optical Fall Time | $t_f(SD)$ | | 0.1 | 0.6 | μs | |
| Receiver Pulse Width | $t_{pw}(RXD)$ | 0.5 | | 8.2 | μs | For in-band EI $\leq 115.2\text{ Kb/s}$ |
| Receiver Latency Time | $t_L(RXD)$ | | 100 | 200 | μs | |
| Receiver Wake-Up Time | $t_{wu}(RXD)$ | | 40 | 100 | μs | |
| Receiver Shutdown Time | $t_{sd}(RXD)$ | | 10 | 100 | μs | |

Application Circuit

| Component | Recommended Value |
|-----------|--|
| R_{LED} | 9.1 Ω , $\pm 5\%$, 0.5 W, for $4.5\text{ V} \leq V_{CC} \leq 5.5\text{ V}$ 3.3 Ω , $\pm 5\%$, 0.5 W, for $3.0\text{ V} \leq V_{CC} \leq 3.6\text{ V}$ |
| CX3 | 0.10 $\mu\text{F} \pm 22\%$. XR7 Ceramic, Lead Length $\leq 5\text{ mm}$. |
| CX4 | 4.7 μF minimum. Larger values recommended for noisy supplies or environments. |

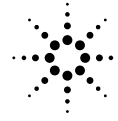

Appendix A. Test Methods

A.1. Background Light and Electromagnetic Field

There are four ambient interference conditions in which the receiver is to operate correctly. The conditions are to be applied separately:

1. Electromagnetic field: 3 V/m maximum (refer to IEC 801-3, severity level 3 for details)

2. Sunlight: 10 kilolux maximum at the optical port

This is simulated with an IR source having a peak wavelength within the range 850 nm to 900 nm and a spectral width less than 50 nm biased to provide $490 \mu\text{W}/\text{cm}^2$ (with no modulation) at the optical port. The light source faces the optical port.

This simulates sunlight within the IrDA spectral range. The effect of longer wavelength radiation is covered by the incandescent condition.

3. Incandescent Lighting: 1000 lux maximum

This is produced with general service, tungsten-filament, gas-filled, inside-frosted lamps in the 60 Watt to 150 Watt range to generate 1000 lux over the horizontal surface on which the equipment under test rests. The light sources are above the test area. The source is expected to have a filament temperature in the 2700 to 3050 degrees Kelvin range and a spectral peak in the 850 nm to 1050 nm range.

4. Fluorescent Lighting: 1000 lux maximum

This is simulated with an IR source having a peak wavelength within the range 850 nm to 900 nm and a spectral width of less than 50 nm biased and modulated to provide an optical square wave signal ($0 \mu\text{W}/\text{cm}^2$ minimum and $0.3 \mu\text{W}/\text{cm}^2$ peak amplitude with 10% to 90% rise and fall times less than or equal to 100 ns) over the horizontal surface on which the equipment under test rests. The light sources are above the test area. The frequency of the optical signal is swept over the frequency range from 20 kHz to 200 kHz.

Due to the variety of fluorescent lamps and the range of IR emissions, this condition is not expected to cover all circumstances. It will provide a common floor for IrDA operation.



LittleDiode supplies new, hard to find or obsolete electronic components and semiconductors all over the world.

With over two million different components listed you are sure to find the part you need.

Feel free to visit us today at our online store:

LittleDiode.com

Looking forward to providing you with the best possible service.