

# CD74AC175, CD74ACT175

## Quad D Flip-Flop with Reset

### Features

- Buffered Inputs
- Typical Propagation Delay
  - 6.4ns at  $V_{CC} = 5V$ ,  $T_A = 25^{\circ}C$ ,  $C_L = 50pF$
- Exceeds 2kV ESD Protection MIL-STD-883, Method 3015
- SCR-Latchup-Resistant CMOS Process and Circuit Design
- Speed of Bipolar FAST™/AS/S with Significantly Reduced Power Consumption
- Balanced Propagation Delays
- AC Types Feature 1.5V to 5.5V Operation and Balanced Noise Immunity at 30% of the Supply
- $\pm 24mA$  Output Drive Current
  - Fanout to 15 FAST™ ICs
  - Drives 50 $\Omega$  Transmission Lines

### Description

The CD74AC175 and CD74ACT175 are quad D flip-flops with reset that utilize the Harris Advanced CMOS Logic technology. Information at the D input is transferred to the Q and  $\bar{Q}$  outputs on the positive-going edge of the clock pulse. All four flip-flops are controlled by a common clock (CP) and a common reset ( $\overline{MR}$ ). Resetting is accomplished by a LOW logic level independent of the clock.

### Ordering Information

PART NUMBER	TEMP. RANGE ( $^{\circ}C$ )	PACKAGE	PKG. NO.
CD74AC175E	-55 to 125	16 Ld PDIP	E16.3
CD74ACT175E	-55 to 125	16 Ld PDIP	E16.3
CD74AC175M	-55 to 125	16 Ld SOIC	M16.15
CD74ACT175M	-55 to 125	16 Ld SOIC	M16.15

#### NOTES:

13. When ordering, use the entire part number. Add the suffix 96 to obtain the variant in the tape and reel.
14. Wafer and die for this part number is available which meets all electrical specifications. Please contact your local sales office or Harris customer service for ordering information.

### Pinout

CD74AC175, CD74ACT175  
(PDIP, SOIC)  
TOP VIEW

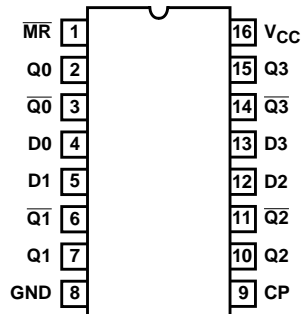

**Functional Diagram**

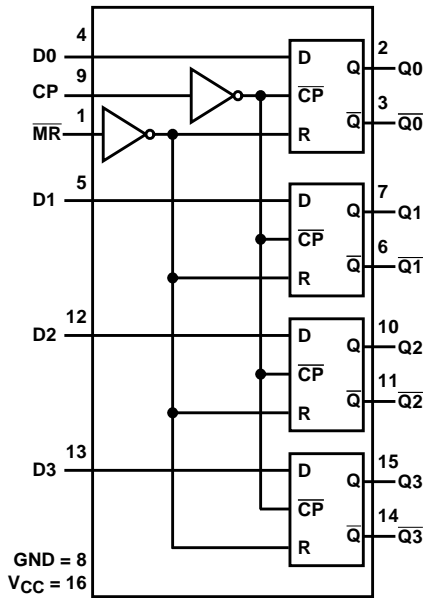

**TRUTH TABLE (EACH FLIP-FLOP)**

INPUTS			OUTPUTS	
RESET (MR)	CLOCK CP	DATA D <sub>n</sub>	Q <sub>n</sub>	$\overline{Q}_n$
L	X	X	L	H
H	↑	H	H	L
H	↑	L	L	H
H	L	X	Q <sub>0</sub>	$\overline{Q}_0$

H = High Level (Steady State)  
 L = Low Level (Steady State)  
 X = Irrelevant  
 ↑ = Transition from Low to High level  
 Q<sub>0</sub>,  $\overline{Q}_0$  = Level before the Indicated Steady-State Input conditions were established.

# CD74AC175, CD74ACT175

## Absolute Maximum Ratings

DC Supply Voltage, $V_{CC}$ .....	-0.5V to 6V
DC Input Diode Current, $I_{IK}$	
For $V_I < -0.5V$ or $V_I > V_{CC} + 0.5V$ .....	$\pm 20mA$
DC Output Diode Current, $I_{OK}$	
For $V_O < -0.5V$ or $V_O > V_{CC} + 0.5V$ .....	$\pm 50mA$
DC Output Source or Sink Current per Output Pin, $I_O$	
For $V_O > -0.5V$ or $V_O < V_{CC} + 0.5V$ .....	$\pm 50mA$
DC $V_{CC}$ or Ground Current, $I_{CC}$ or $I_{GND}$ (Note 3) .....	$\pm 100mA$

## Thermal Information

Thermal Resistance (Typical, Note 5)	$\theta_{JA}$ ( $^{\circ}C/W$ )
PDIP Package .....	90
SOIC Package .....	160
Maximum Junction Temperature (Plastic Package) .....	$150^{\circ}C$
Maximum Storage Temperature Range .....	$-65^{\circ}C$ to $150^{\circ}C$
Maximum Lead Temperature (Soldering 10s) .....	$300^{\circ}C$ (SOIC - Lead Tips Only)

## Operating Conditions

Temperature Range, $T_A$ .....	$-55^{\circ}C$ to $125^{\circ}C$
Supply Voltage Range, $V_{CC}$ (Note 4)	
AC Types .....	1.5V to 5.5V
ACT Types .....	4.5V to 5.5V
DC Input or Output Voltage, $V_I$ , $V_O$ .....	0V to $V_{CC}$
Input Rise and Fall Slew Rate, dt/dv	
AC Types, 1.5V to 3V .....	50ns (Max)
AC Types, 3.6V to 5.5V .....	20ns (Max)
ACT Types, 4.5V to 5.5V .....	10ns (Max)

*CAUTION: Stresses above those listed in "Absolute Maximum Ratings" may cause permanent damage to the device. This is a stress only rating and operation of the device at these or any other conditions above those indicated in the operational sections of this specification is not implied.*

### NOTES:

15. For up to 4 outputs per device, add  $\pm 25mA$  for each additional output.
16. Unless otherwise specified, all voltages are referenced to ground.
17.  $\theta_{JA}$  is measured with the component mounted on an evaluation PC board in free air.

## DC Electrical Specifications

PARAMETER	SYMBOL	TEST CONDITIONS		$V_{CC}$ (V)	25 $^{\circ}C$		-40 $^{\circ}C$ TO 85 $^{\circ}C$		-55 $^{\circ}C$ TO 125 $^{\circ}C$		UNITS	
		$V_I$ (V)	$I_O$ (mA)		MIN	MAX	MIN	MAX	MIN	MAX		
<b>AC TYPES</b>												
High Level Input Voltage	$V_{IH}$	-	-	1.5	1.2	-	1.2	-	1.2	-	V	
				3	2.1	-	2.1	-	2.1	-	V	
				5.5	3.85	-	3.85	-	3.85	-	V	
Low Level Input Voltage	$V_{IL}$	-	-	1.5	-	0.3	-	0.3	-	0.3	V	
				3	-	0.9	-	0.9	-	0.9	V	
				5.5	-	1.65	-	1.65	-	1.65	V	
High Level Output Voltage	$V_{OH}$	$V_{IH}$ or $V_{IL}$	-0.05	-0.05	1.5	1.4	-	1.4	-	1.4	-	V
			-0.05	-0.05	3	2.9	-	2.9	-	2.9	-	V
			-0.05	-0.05	4.5	4.4	-	4.4	-	4.4	-	V
			-4	-4	3	2.58	-	2.48	-	2.4	-	V
			-24	-24	4.5	3.94	-	3.8	-	3.7	-	V
			-75 (Note 6, 7)	-75	5.5	-	-	3.85	-	-	-	V
			-50 (Note 6, 7)	-50	5.5	-	-	-	-	3.85	-	V

## CD74AC175, CD74ACT175

### DC Electrical Specifications (Continued)

PARAMETER	SYMBOL	TEST CONDITIONS		V <sub>CC</sub> (V)	25°C		-40°C TO 85°C		-55°C TO 125°C		UNITS
		V <sub>I</sub> (V)	I <sub>O</sub> (mA)		MIN	MAX	MIN	MAX	MIN	MAX	
Low Level Output Voltage	V <sub>OL</sub>	V <sub>IH</sub> or V <sub>IL</sub>	0.05	1.5	-	0.1	-	0.1	-	0.1	V
			0.05	3	-	0.1	-	0.1	-	0.1	V
			0.05	4.5	-	0.1	-	0.1	-	0.1	V
			12	3	-	0.36	-	0.44	-	0.5	V
			24	4.5	-	0.36	-	0.44	-	0.5	V
			75 (Note 6, 7)	5.5	-	-	-	1.65	-	-	V
			50 (Note 6, 7)	5.5	-	-	-	-	-	1.65	V
Input Leakage Current	I <sub>I</sub>	V <sub>CC</sub> or GND	-	5.5	-	±0.1	-	±1	-	±1	μA
Quiescent Supply Current MSI	I <sub>CC</sub>	V <sub>CC</sub> or GND	0	5.5	-	8	-	80	-	160	μA
<b>ACT TYPES</b>											
High Level Input Voltage	V <sub>IH</sub>	-	-	4.5 to 5.5	2	-	2	-	2	-	V
Low Level Input Voltage	V <sub>IL</sub>	-	-	4.5 to 5.5	-	0.8	-	0.8	-	0.8	V
High Level Output Voltage	V <sub>OH</sub>	V <sub>IH</sub> or V <sub>IL</sub>	-0.05	4.5	4.4	-	4.4	-	4.4	-	V
			-24	4.5	3.94	-	3.8	-	3.7	-	V
			-75 (Note 6, 7)	5.5	-	-	3.85	-	-	-	V
			-50 (Note 6, 7)	5.5	-	-	-	-	3.85	-	V
Low Level Output Voltage	V <sub>OL</sub>	V <sub>IH</sub> or V <sub>IL</sub>	0.05	4.5	-	0.1	-	0.1	-	0.1	V
			24	4.5	-	0.36	-	0.44	-	0.5	V
			75 (Note 6, 7)	5.5	-	-	-	1.65	-	-	V
			50 (Note 6, 7)	5.5	-	-	-	-	-	1.65	V
Input Leakage Current	I <sub>I</sub>	V <sub>CC</sub> or GND	-	5.5	-	±0.1	-	±1	-	±1	μA
Quiescent Supply Current MSI	I <sub>CC</sub>	V <sub>CC</sub> or GND	0	5.5	-	8	-	80	-	160	μA
Additional Supply Current per Input Pin TTL Inputs High 1 Unit Load	ΔI <sub>CC</sub>	V <sub>CC</sub> -2.1	-	4.5 to 5.5	-	2.4	-	2.8	-	3	mA

**NOTES:**

18. Test one output at a time for a 1-second maximum duration. Measurement is made by forcing current and measuring voltage to minimize power dissipation.
19. Test verifies a minimum 50Ω transmission-line-drive capability at 85°C, 75Ω at 125°C.

### ACT Input Load Table

INPUT	UNIT LOAD
Dn	0.58
MR	0.67
CP	0.92

NOTE: Unit load is ΔI<sub>CC</sub> limit specified in DC Electrical Specifications Table, e.g., 2.4mA max at 25°C.

**CD74AC175, CD74ACT175**

**Prerequisite For Switching Function**

PARAMETER	SYMBOL	V <sub>CC</sub> (V)	-40°C TO 85°C		-55°C TO 125°C		UNITS
			MIN	MAX	MIN	MAX	
<b>AC TYPES</b>							
Data to CP Set-Up Time	t <sub>SU</sub>	1.5	2	-	2	-	ns
		3.3 (Note 8)	2	-	2	-	ns
		5 (Note 9)	2	-	2	-	ns
Hold Time	t <sub>H</sub>	1.5	2	-	2	-	ns
		3.3	2	-	2	-	ns
		5	2	-	2	-	ns
Removal Time, $\overline{MR}$ to CP	t <sub>REM</sub>	1.5	1	-	1	-	ns
		3.3	1	-	1	-	ns
		5	1	-	1	-	ns
$\overline{MR}$ Pulse Width	t <sub>W</sub>	1.5	44	-	50	-	ns
		3.3	4.9	-	5.6	-	ns
		5	3.5	-	4	-	ns
CP Pulse Width	t <sub>W</sub>	1.5	55	-	63	-	ns
		3.3	6.1	-	7	-	ns
		5	4.4	-	5	-	ns
CP Frequency	f <sub>MAX</sub>	1.5	9	-	8	-	MHz
		3.3	81	-	71	-	MHz
		5	114	-	100	-	MHz
<b>ACT TYPES</b>							
Data to CP Set-Up Time	t <sub>SU</sub>	5 (Note 9)	2	-	2	-	ns
Hold Time	t <sub>H</sub>	5	2	-	2	-	ns
Removal Time, $\overline{MR}$ to CP	t <sub>REM</sub>	5	1	-	1	-	ns
$\overline{MR}$ Pulse Width	t <sub>W</sub>	5	3.5	-	4	-	ns
Clock Pulse Width	t <sub>W</sub>	5	4.4	-	5	-	ns
CP Frequency	f <sub>MAX</sub>	5	114	-	114	-	MHz

NOTES:

20. 3.3V Min is at 3V.

21. 5V Min is at 4.5V.

**Switching Specifications** Input t<sub>r</sub>, t<sub>f</sub> = 3ns, C<sub>L</sub> = 50pF (Worst Case)

PARAMETER	SYMBOL	V <sub>CC</sub> (V)	-40°C TO 85°C			-55°C TO 125°C			UNITS
			MIN	TYP	MAX	MIN	TYP	MAX	
<b>AC TYPES</b>									
Propagation Delay, CP to Q, $\overline{Q}$	t <sub>PLH</sub> , t <sub>PHL</sub>	1.5	-	-	139	-	-	153	ns
		3.3 (Note 11)	4.4	-	15.5	4.3	-	17.1	ns
		5 (Note 12)	3.2	-	11.1	3.1	-	12.2	ns

# CD74AC175, CD74ACT175

## Switching Specifications Input $t_r, t_f = 3\text{ns}$ , $C_L = 50\text{pF}$ (Worst Case) (Continued)

PARAMETER	SYMBOL	$V_{CC}$ (V)	-40°C TO 85°C			-55°C TO 125°C			UNITS
			MIN	TYP	MAX	MIN	TYP	MAX	
Propagation Delay, $\overline{MR}$ to Q, $\overline{Q}$	$t_{PLH}, t_{PHL}$	1.5	-	-	139	-	-	153	ns
		3.3	4.4	-	15.5	4.3	-	17.1	ns
		5	3.2	-	11.1	3.1	-	12.2	ns
Input Capacitance	$C_I$	-	-	-	10	-	-	10	pF
Power Dissipation Capacitance	$C_{PD}$ (Note 13)	-	-	55	-	-	55	-	pF
<b>ACT TYPES</b>									
Propagation Delay, CP to Qn	$t_{PLH}, t_{PHL}$	5 (Note 12)	3	-	10.5	2.9	-	11.5	ns
Propagation Delay, $\overline{MR}$ to Qn	$t_{PLH}, t_{PHL}$	5	3.3	-	11.8	3.3	-	13	ns
Input Capacitance	$C_I$	-	-	-	10	-	-	10	pF
Power Dissipation Capacitance	$C_{PD}$ (Note 13)	-	-	55	-	-	55	-	pF

**NOTES:**

22. Limits tested 100%.
23. 3.3V Min is at 3.6V, Max is at 3V.
24. 5V Min is at 5.5V, Max is at 4.5V.
25.  $C_{PD}$  is used to determine the dynamic power consumption per flip-flop.  
 $P_D = C_{PD} V_{CC}^2 f_i + \Sigma (C_L + V_{CC}^2 f_o) + V_{CC} \Delta I_{CC}$  where  $f_i$  = input frequency,  $f_o$  = output frequency,  $C_L$  = output load capacitance,  $V_{CC}$  = supply voltage.

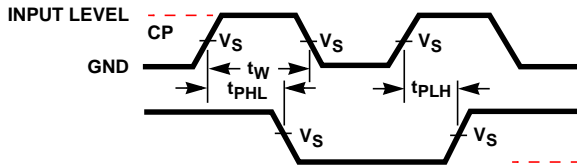

FIGURE 5. PROPAGATION DELAYS

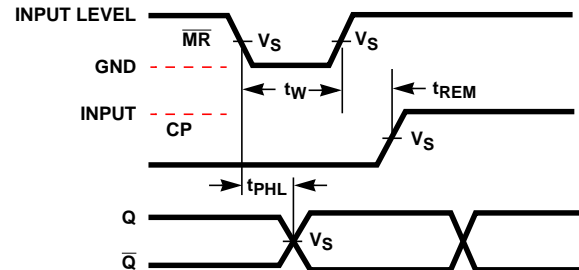

FIGURE 6. RESET OR SET PREREQUISITE AND PROPAGATION DELAYS

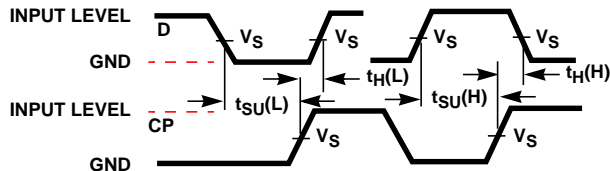
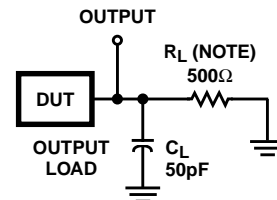

FIGURE 7.



NOTE: For AC Series Only: When  $V_{CC} = 1.5\text{V}$ ,  $R_L = 1\text{k}\Omega$ .

	CD74AC	CD74ACT
Input Level	$V_{CC}$	3V
Input Switching Voltage, $V_S$	$0.5 V_{CC}$	1.5V
Output Switching Voltage, $V_S$	$0.5 V_{CC}$	$0.5 V_{CC}$

FIGURE 8. PROPAGATION DELAY TIMES

## IMPORTANT NOTICE

Texas Instruments and its subsidiaries (TI) reserve the right to make changes to their products or to discontinue any product or service without notice, and advise customers to obtain the latest version of relevant information to verify, before placing orders, that information being relied on is current and complete. All products are sold subject to the terms and conditions of sale supplied at the time of order acknowledgement, including those pertaining to warranty, patent infringement, and limitation of liability.

TI warrants performance of its semiconductor products to the specifications applicable at the time of sale in accordance with TI's standard warranty. Testing and other quality control techniques are utilized to the extent TI deems necessary to support this warranty. Specific testing of all parameters of each device is not necessarily performed, except those mandated by government requirements.

CERTAIN APPLICATIONS USING SEMICONDUCTOR PRODUCTS MAY INVOLVE POTENTIAL RISKS OF DEATH, PERSONAL INJURY, OR SEVERE PROPERTY OR ENVIRONMENTAL DAMAGE ("CRITICAL APPLICATIONS"). TI SEMICONDUCTOR PRODUCTS ARE NOT DESIGNED, AUTHORIZED, OR WARRANTED TO BE SUITABLE FOR USE IN LIFE-SUPPORT DEVICES OR SYSTEMS OR OTHER CRITICAL APPLICATIONS. INCLUSION OF TI PRODUCTS IN SUCH APPLICATIONS IS UNDERSTOOD TO BE FULLY AT THE CUSTOMER'S RISK.

In order to minimize risks associated with the customer's applications, adequate design and operating safeguards must be provided by the customer to minimize inherent or procedural hazards.

TI assumes no liability for applications assistance or customer product design. TI does not warrant or represent that any license, either express or implied, is granted under any patent right, copyright, mask work right, or other intellectual property right of TI covering or relating to any combination, machine, or process in which such semiconductor products or services might be or are used. TI's publication of information regarding any third party's products or services does not constitute TI's approval, warranty or endorsement thereof.

This datasheet has been downloaded from:

[www.DatasheetCatalog.com](http://www.DatasheetCatalog.com)

Datasheets for electronic components.

# Texas Instruments

<http://www.ti.com>

This file is the datasheet for the following electronic components:

74ACT175 - <http://www.ti.com/product/74act175?HQS=TI-null-null-dscatalog-df-pf-null-ww>

CD74AC175E - <http://www.ti.com/product/cd74ac175e?HQS=TI-null-null-dscatalog-df-pf-null-ww>



LittleDiode supplies new, hard to find or obsolete electronic components and semiconductors all over the world.

With over two million different components listed you are sure to find the part you need.

Feel free to visit us today at our online store:

[LittleDiode.com](http://LittleDiode.com)

Looking forward to providing you with the best possible service.