

CD4043BM/CD4043BC Quad TRI-STATE[®] NOR R/S Latches

CD4044BM/CD4044BC Quad TRI-STATE[®] NAND R/S Latches

General Description

CD4043BM/CD4043BC are quad cross-couple TRI-STATE CMOS NOR latches, and CD4044BM/CD4044BC are quad cross-couple TRI-STATE CMOS NAND latches. Each latch has a separate Q output and individual SET and RESET inputs. There is a common TRI-STATE ENABLE input for all four latches. A logic "1" on the ENABLE input connects the latch states to the Q outputs. A logic "0" on the ENABLE input disconnects the latch states from the Q outputs resulting in an open circuit condition on the Q output. The TRI-STATE feature allows common bussing of the outputs.

Features

- Wide supply voltage range 3V to 15V
- Low power 100 nW (typ.)
- High noise immunity 0.45 V_{DD} (typ.)
- Separate SET and RESET for each latch
- NOR and NAND configuration
- TRI-STATE output with common output enable

Applications

- Multiple bus storage
- Strobed register
- Four bits of independent storage with output enable
- General digital logic

Connection Diagrams

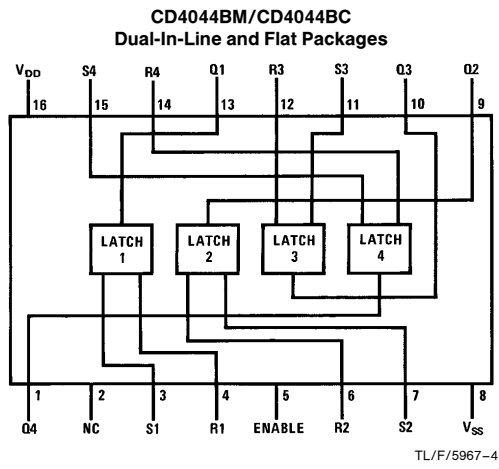
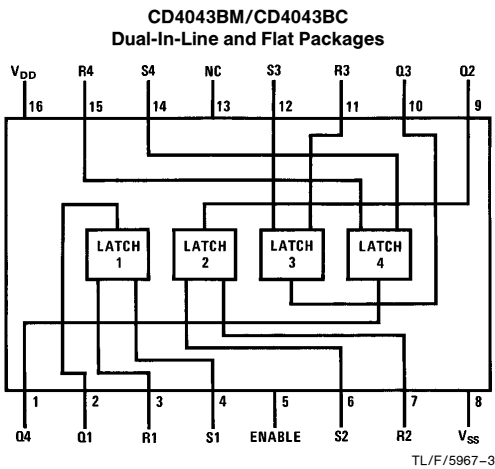

Truth Table

CD4043BM/CD4043BC				CD4044BM/CD4044BC			
S	R	E	Q	S	R	E	Q
X	X	0	OC	X	X	0	OC
0	0	1	NC	1	1	1	NC
1	0	1	1	0	1	1	1
0	1	1	0	1	0	1	0
1	1	1	Δ	0	0	1	ΔΔ

OC — TRI-STATE
 NC — No change
 X — Don't care
 Δ — Dominated by S=1 input
 ΔΔ — Dominated by R=0 input

Order Number CD4043B or CD4044B

CD4043BM/CD4043BC Quad TRI-STATE[®] NOR R/S Latches
 CD4044BM/CD4044BC Quad TRI-STATE[®] NAND R/S Latches

Absolute Maximum Ratings (Notes 1 and 2)

If Military/Aerospace specified devices are required, please contact the National Semiconductor Sales Office/Distributors for availability and specifications.

Supply Voltage (V_{DD})	-0.5V to +18V
Input Voltage (V_{IN})	-0.5V to V_{DD} + 0.5V
Storage Temperature Range (T_S)	-65°C to +150°C
Power Dissipation (P_D)	
Dual-In-Line	700 mW
Small Outline	500 mW
Lead Temperature (T_L)	
(Soldering, 10 seconds)	260°C

Recommended Operating Conditions (Note 2)

Supply Voltage (V_{DD})	3.0V to 15V
Input Voltage (V_{IN})	0 to V_{DD} V
Operating Temperature Range (T_A)	
CD4043BM, CD4044BM	-55°C to +125°C
CD4043BC, CD4044BC	-40°C to +85°C

DC Electrical Characteristics CD4043BM/CD4044BM (Note 2)

Symbol	Parameter	Conditions	-55°C		+25°C			+125°C		Units
			Min	Max	Min	Typ	Max	Min	Max	
I_{DD}	Quiescent Device Current	$V_{DD} = 5V, V_{IN} = V_{DD}$ or V_{SS}		5.0		0.01	5.0		150	μA
		$V_{DD} = 10V, V_{IN} = V_{DD}$ or V_{SS}		10		0.01	10		300	μA
		$V_{DD} = 15V, V_{IN} = V_{DD}$ or V_{SS}		20		0.02	20		600	μA
V_{OL}	Low Level Output Voltage	$ I_O \leq 1 \mu A, V_{IL} = 0V, V_{IH} = V_{DD}$		0.05		0	0.05		0.05	V
		$V_{DD} = 5.0V$		0.05		0	0.05		0.05	V
		$V_{DD} = 10V$		0.05		0	0.05		0.05	V
V_{OH}	High Level Output Voltage	$ I_O \leq 1 \mu A, V_{IL} = 0V, V_{IH} = V_{DD}$								V
		$V_{DD} = 5.0V$	4.95		4.95	5.0		4.95		V
		$V_{DD} = 10V$	9.95		9.95	10		9.95		V
V_{IL}	Low Level Input Voltage	$ I_O \leq 1 \mu A$								V
		$V_{DD} = 5.0V, V_O = 0.5V$ or $4.5V$		1.5		2.25	1.5		1.5	V
		$V_{DD} = 10V, V_O = 1.0V$ or $9.0V$		3.0		4.5	3.0		3.0	V
V_{IH}	High Level Input Voltage	$ I_O \leq 1 \mu A$								V
		$V_{DD} = 5.0V, V_O = 0.5V$ or $4.5V$	3.5		3.5	2.75		3.5		V
		$V_{DD} = 10V, V_O = 1.0V$ or $9.0V$	7.0		7.0	5.5		7.0		V
I_{OL}	Low Level Output Current	$V_{IL} = 0V, V_{IH} = V_{DD}$								mA
		$V_{DD} = 5.0V, V_O = 0.4V$	0.64		0.51	1.0		0.36		mA
		$V_{DD} = 10V, V_O = 0.5V$	1.6		1.3	2.6		0.9		mA
I_{OH}	High Level Output Current	$V_{IL} = 0V, V_{IH} = V_{DD}$								mA
		$V_{DD} = 5.0V, V_O = 4.6V$	-0.64		-0.51	-0.4		-0.36		mA
		$V_{DD} = 10V, V_O = 9.5V$	-1.6		-1.3	-1.0		-0.9		mA
I_{IN}	Input Current	$V_{DD} = 15V, V_{IN} = 0V$		-0.1		-10^{-5}	-0.1		-1.0	μA
		$V_{DD} = 15V, V_{IN} = 15V$		0.1		10^{-5}	0.1		1.0	μA

DC Electrical Characteristics CD4043BC/CD4044BC (Note 2)

Symbol	Parameter	Conditions	-40°C		+25°C			+85°C		Units
			Min	Max	Min	Typ	Max	Min	Max	
I_{DD}	Quiescent Device Current	$V_{DD} = 5V, V_{IN} = V_{DD}$ or V_{SS}		20		0.01	20		150	μA
		$V_{DD} = 10V, V_{IN} = V_{DD}$ or V_{SS}		40		0.01	40		300	μA
		$V_{DD} = 15V, V_{IN} = V_{DD}$ or V_{SS}		80		0.02	80		600	μA
V_{OL}	Low Level Output Voltage	$ I_O \leq 1 \mu A, V_{IL} = 0V, V_{IH} = V_{DD}$		0.05		0	0.05		0.05	V
		$V_{DD} = 5.0V$		0.05		0	0.05		0.05	V
		$V_{DD} = 10V$		0.05		0	0.05		0.05	V
V_{OH}	High Level Output Voltage	$ I_O \leq 1 \mu A, V_{IL} = 0V, V_{IH} = V_{DD}$								V
		$V_{DD} = 5.0V$	4.95		4.95	5.0		4.95		V
		$V_{DD} = 10V$	9.95		9.95	10		9.95		V
V_{IL}	Low Level Input Voltage	$ I_O \leq 1 \mu A$								V
		$V_{DD} = 5.0V, V_O = 0.5V$ or $4.5V$		1.5		2.25	1.5		1.5	V
		$V_{DD} = 10V, V_O = 1.0V$ or $9.0V$		3.0		4.5	3.0		3.0	V
V_{IH}	High Level Input Voltage	$ I_O \leq 1 \mu A$								V
		$V_{DD} = 5.0V, V_O = 0.5V$ or $4.5V$	3.5		3.5	2.75		3.5		V
		$V_{DD} = 10V, V_O = 1.0V$ or $9.0V$	7.0		7.0	5.5		7.0		V
I_{OL}	Low Level Output Current	$V_{IL} = 0V, V_{IH} = V_{DD}$								mA
		$V_{DD} = 5.0V, V_O = 0.4V$	0.64		0.51	1.0		0.36		mA
		$V_{DD} = 10V, V_O = 0.5V$	1.6		1.3	2.6		0.9		mA
I_{OH}	High Level Output Current	$V_{IL} = 0V, V_{IH} = V_{DD}$								mA
		$V_{DD} = 5.0V, V_O = 4.6V$	-0.64		-0.51	-0.4		-0.36		mA
		$V_{DD} = 10V, V_O = 9.5V$	-1.6		-1.3	-1.0		-0.9		mA
I_{IN}	Input Current	$V_{DD} = 15V, V_{IN} = 0V$		-0.1		-10^{-5}	-0.1		-1.0	μA
		$V_{DD} = 15V, V_{IN} = 15V$		0.1		10^{-5}	0.1		1.0	μA

DC Electrical Characteristics CD4043BC/CD4044BC (Continued)

Symbol	Parameter	Conditions	-40°C		+25°C			+85°C		Units
			Min	Max	Min	Typ	Max	Min	Max	
V _{IL}	Low Level Input Voltage	I _O ≤ 1 μA V _{DD} = 5.0V, V _O = 0.5V or 4.5V V _{DD} = 10V, V _O = 1.0V or 9.0V V _{DD} = 15V, V _O = 1.5V or 13.5V		1.5		2.25	1.5		1.5	V
				3.0		4.5	3.0		3.0	V
				4.0		6.75	4.0		4.0	V
V _{IH}	High Level Input Voltage	I _O ≤ 1 μA V _{DD} = 5.0V, V _O = 0.5V or 4.5V V _{DD} = 5.0V, V _O = 1.0V or 9.0V V _{DD} = 15V, V _O = 1.5V or 13.5V	3.5		3.5			3.5		V
			7.0		7.0			7.0		V
			11		11			11		V
I _{OL}	Low Level Output Current (Note 3)	V _{IL} = 0V, V _{IH} = V _{DD} V _{DD} = 5.0V, V _O = 0.4V V _{DD} = 10V, V _O = 0.5V V _{DD} = 15V, V _O = 1.5V	0.52		0.44	0.88		0.36		mA
			1.3		1.1	2.2		0.9		mA
			3.6		3.0	6.0		2.4		mA
I _{OH}	High Level Output Current (Note 3)	V _{IL} = 0V, V _{IH} = V _{DD} V _{DD} = 5.0V, V _O = 4.6V V _{DD} = 10V, V _O = 9.5V V _{DD} = 15V, V _O = 13.5V	-0.52		-0.44	-0.32		-0.36		mA
			-1.3		-1.1	-0.8		-0.9		mA
			-3.6		-3.0	-2.4		-2.4		mA
I _{IN}	Input Current	V _{DD} = 15V, V _{IN} = 0V V _{DD} = 15V, V _{IN} = 15V	-0.3			-0.3			-1.0	μA
			0.3			0.3			1.0	μA

AC Electrical Characteristics*

T_A = 25°C, C_L = 50 pF, R_L = 200k, input t_r = t_f = 20 ns, unless otherwise noted

Symbol	Parameter	Conditions	Min	Typ	Max	Units
t _{PLH} , t _{PHL}	Propagation Delay S or R to Q	V _{DD} = 5.0V		175	350	ns
		V _{DD} = 10V		75	175	ns
		V _{DD} = 15V		60	120	ns
t _{PZH} , t _{PHZ}	Propagation Delay Enable to Q (High)	V _{DD} = 5.0V		115	230	ns
		V _{DD} = 10V		55	110	ns
		V _{DD} = 15V		40	80	ns
t _{PZL} , t _{PLZ}	Propagation Delay Enable to Q (Low)	V _{DD} = 5.0V		100	200	ns
		V _{DD} = 10V		50	100	ns
		V _{DD} = 15V		40	80	ns
t _{THL} , t _{TLH}	Transition Time	V _{DD} = 5.0V		100	200	ns
		V _{DD} = 10V		50	100	ns
		V _{DD} = 15V		40	80	ns
t _{WO}	Minimum SET or RESET Pulse Width	V _{DD} = 5.0V		80	160	ns
		V _{DD} = 10V		40	80	ns
		V _{DD} = 15V		20	40	ns
C _{IN}	Input Capacitance			5.0	7.5	pF

*AC Parameters are guaranteed by DC correlated testing.

Note 1: "Absolute Maximum Ratings" are those values beyond which the safety of the device cannot be guaranteed; they are not meant to imply that the devices should be operated at these limits. The tables of "Recommended Operating Conditions" and "Electrical Characteristics" provide conditions for actual device operation.

Note 2: V_{SS} = 0V unless otherwise specified.

Note 3: I_{OH} and I_{OL} are tested one output at a time.

Schematic Diagrams

CD4043BM/CD4043BC

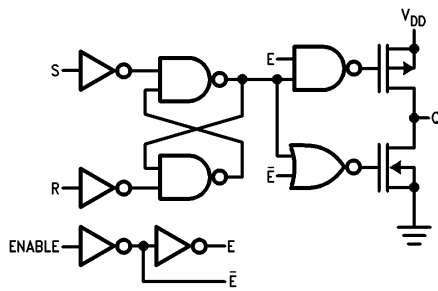

TL/F/5967-1

CD4044BM/CD4044BC

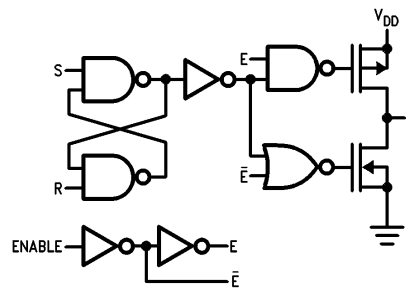

TL/F/5967-2

Timing Waveforms

CD4043B

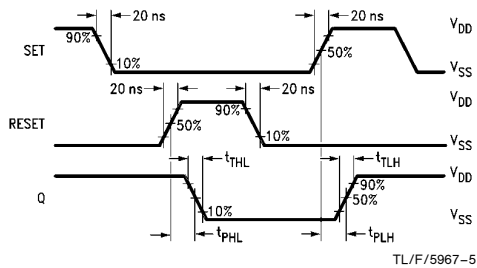

TL/F/5967-5

CD4044B

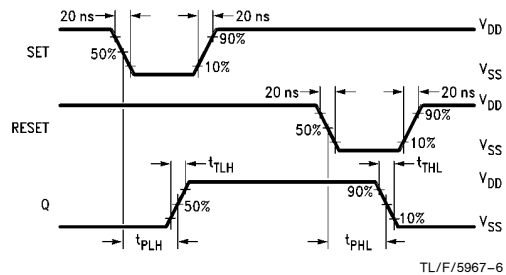

TL/F/5967-6

Enable Timing

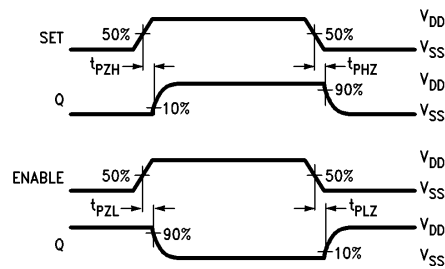

TL/F/5967-7

Physical Dimensions inches (millimeters)

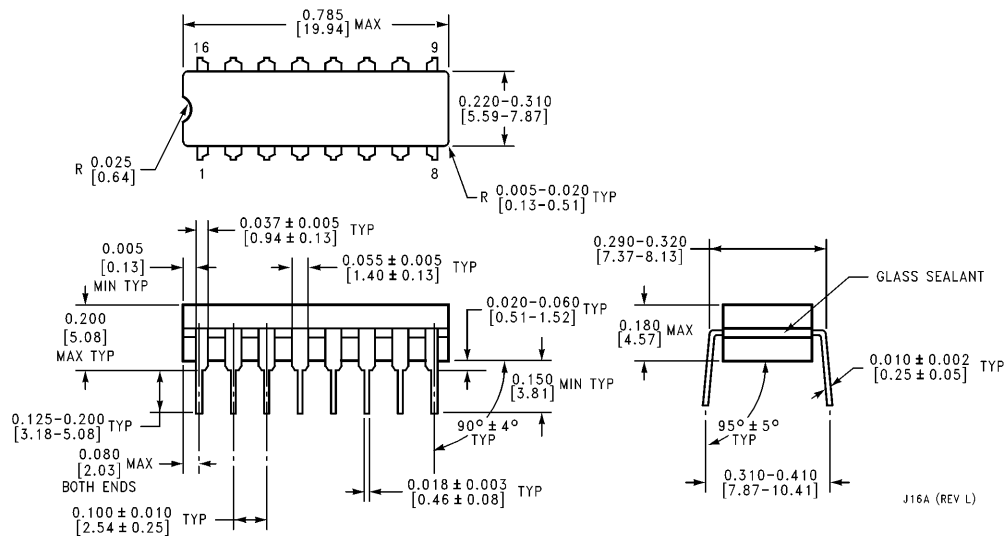

J16A (REV L)

Ceramic Dual-In-Line Package (J)
Order Number CD4043BMJ, CD4043BCJ, CD4044BMJ or CD4044BCJ
NS Package Number J16A

Physical Dimensions inches (millimeters) (Continued)

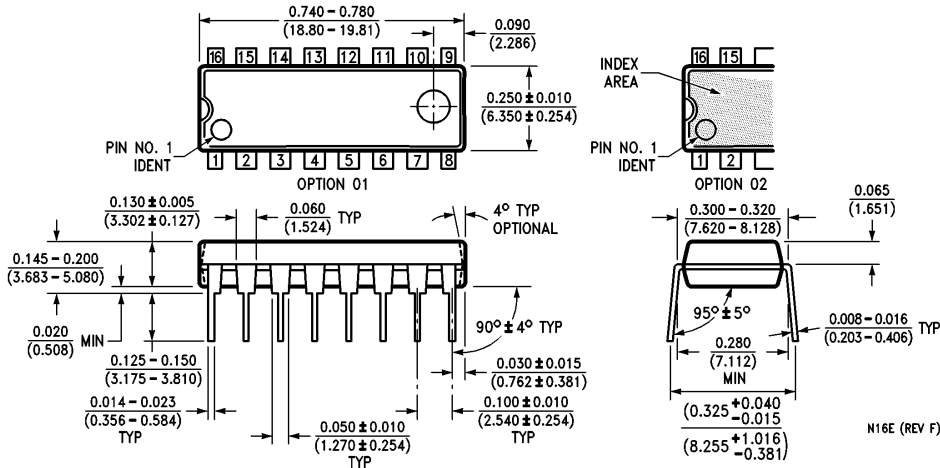

Molded Dual-In-Line Package (N)
 Order Number CD4043BMN, CD4043BCN, CD4044BMN or CD4044BCN
 NS Package Number N16E

LIFE SUPPORT POLICY

NATIONAL'S PRODUCTS ARE NOT AUTHORIZED FOR USE AS CRITICAL COMPONENTS IN LIFE SUPPORT DEVICES OR SYSTEMS WITHOUT THE EXPRESS WRITTEN APPROVAL OF THE PRESIDENT OF NATIONAL SEMICONDUCTOR CORPORATION. As used herein:

1. Life support devices or systems are devices or systems which, (a) are intended for surgical implant into the body, or (b) support or sustain life, and whose failure to perform, when properly used in accordance with instructions for use provided in the labeling, can be reasonably expected to result in a significant injury to the user.
2. A critical component is any component of a life support device or system whose failure to perform can be reasonably expected to cause the failure of the life support device or system, or to affect its safety or effectiveness.



National Semiconductor Corporation
 1111 West Bardin Road
 Arlington, TX 76017
 Tel: 1(800) 272-9959
 Fax: 1(800) 737-7018

National Semiconductor Europe
 Fax: (+49) 0-180-530 85 86
 Email: onjwge@tevm2.nsc.com
 Deutsch Tel: (+49) 0-180-530 85 85
 English Tel: (+49) 0-180-532 78 32
 Français Tel: (+49) 0-180-532 93 58
 Italiano Tel: (+49) 0-180-534 16 80

National Semiconductor Hong Kong Ltd.
 19th Floor, Straight Block,
 Ocean Centre, 5 Canton Rd.
 Tsimshatsui, Kowloon
 Hong Kong
 Tel: (852) 2737-1600
 Fax: (852) 2736-9960

National Semiconductor Japan Ltd.
 Tel: 81-043-299-2309
 Fax: 81-043-299-2408

National does not assume any responsibility for use of any circuitry described, no circuit patent licenses are implied and National reserves the right at any time without notice to change said circuitry and specifications.

National Semiconductor was acquired by Texas Instruments.

http://www.ti.com/corp/docs/investor_relations/pr_09_23_2011_national_semiconductor.html

This file is the datasheet for the following electronic components:

CD4043BM - <http://www.ti.com/product/cd4043bm?HQS=TI-null-null-dscatalog-df-pf-null-ww>

CD4043BC - <http://www.ti.com/product/cd4043bc?HQS=TI-null-null-dscatalog-df-pf-null-ww>

CD4044BM - <http://www.ti.com/product/cd4044bm?HQS=TI-null-null-dscatalog-df-pf-null-ww>

CD4044BC - <http://www.ti.com/product/cd4044bc?HQS=TI-null-null-dscatalog-df-pf-null-ww>



LittleDiode supplies new, hard to find or obsolete electronic components and semiconductors all over the world.

With over two million different components listed you are sure to find the part you need.

Feel free to visit us today at our online store:

LittleDiode.com

Looking forward to providing you with the best possible service.