

# Agilent AEAS-72AA-xxxAA Absolute Encoder Data Sheet

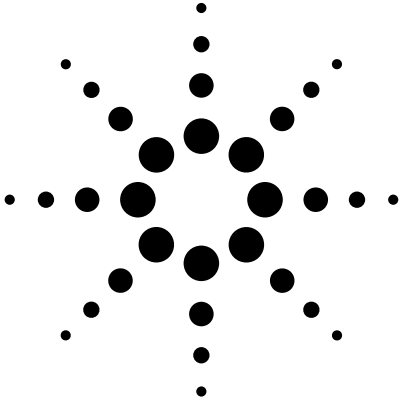

## Description

The AEAS-72AA-xxxAA absolute encoder is a feedback device that has the capability to generate a unique binary 'word' for each encoder shaft position. The AEAS-72AA-xxxAA also has the unique feature of being able to provide positional information upon power up without the need for codewheel movement, unlike incremental encoders, which need codewheel movement to provide positional information.

Each absolute encoder from the AEAS-72AA-xxxAA consists of a lensed LED (Light Emitting Diode)

source, an integrated circuit with detectors and output circuitry, and a special multi-track glass codewheel that rotates between the emitter and detector IC. These 3 main components are contained within a strong metal housing fitted with bearings to produce an IP rated encoder capable of working in dusty conditions.

## Features

- Gray code
- High or low power source options
- IP 50 rating
- 38 mm package diameter
- 8 bits resolution
- 6 mm shaft diameter
- The package comes with 0.5 m long cable



## Applications

- Tool changers and axis control for machine tools
- Robotics
- Telescopes and antennas
- Rotary and X - Y positioning tables
- Medical scanners

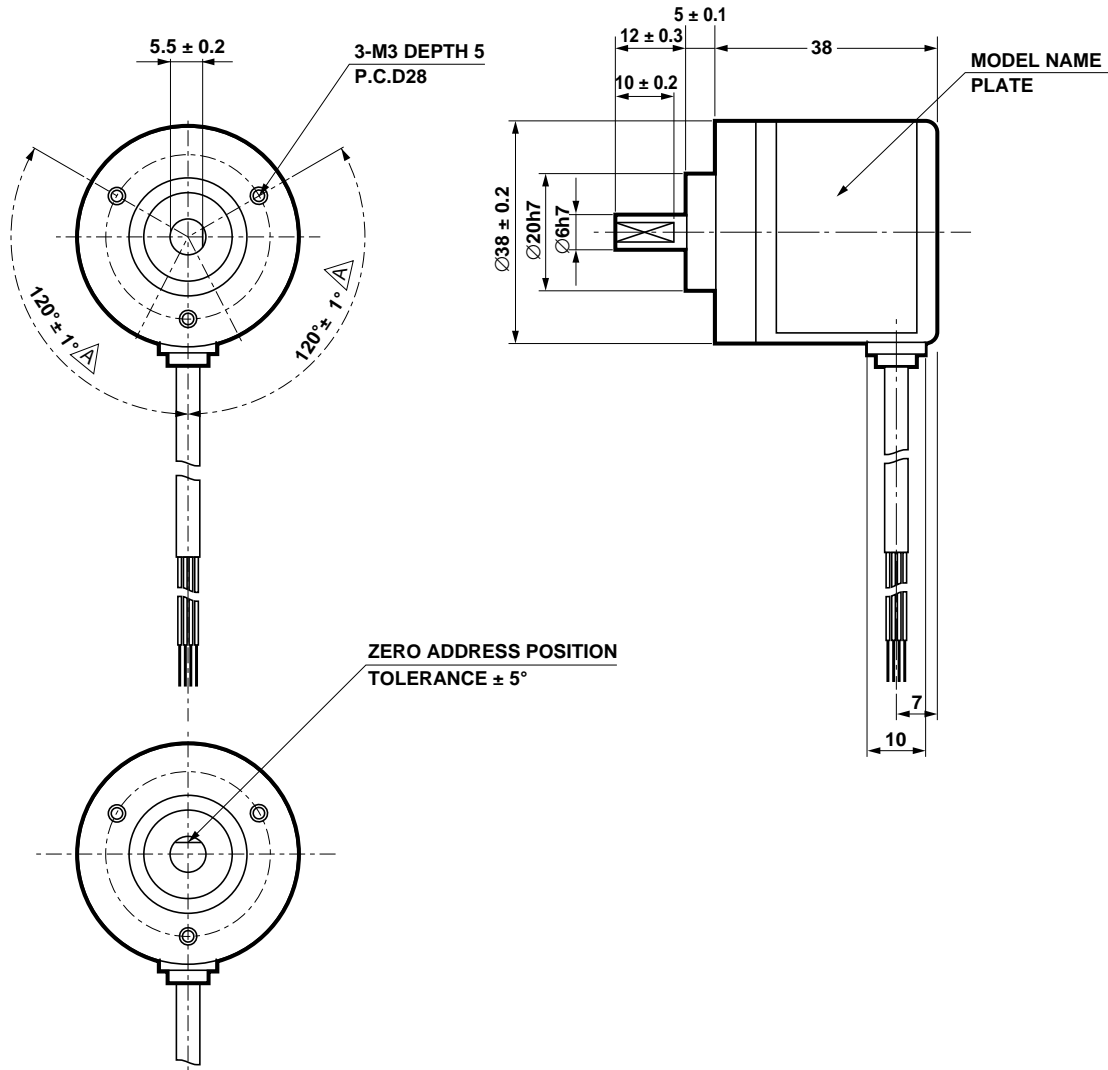

# Package Dimensions



 <b>Agilent Technologies</b> ABSOLUTE ENCODER PART No: AEAS-72AA-XXXAA SERIAL No: XX-XXX MADE IN JAPAN 	<b>CONNECTIONS</b>			
	RED +*~*V	BLU	24	
	BLK OV.COM	VLT	25	
	BRN 2 <sup>0</sup>	GRA	26	
	ORN 2 <sup>1</sup>	WHT	27	
	YEL 2 <sup>2</sup>	SHIELD FG		
GRN 2 <sup>3</sup>				

TOLERANCE IS ± 0.5 mm UNLESS OTHERWISE SPECIFIED.  
 TYPICAL DIMENSIONS IN MILLIMETERS.

JIS (JAPANESE INDUSTRIAL STANDARD)	DEFINITION (mm)
20h7	20 <sup>+0</sup> -0.021
6h7	6 <sup>+0</sup> -0.015

NOTE: INFORMATION FROM JIS B0401(1999)

### Theory of Operation

The AEAS-72AA-xxxAA is a single-turn, low-cost, and compact absolute encoder which uses optical technology to provide absolute positioning information.

The AEAS-72AA-xxxAA consists of a LED, Fixed Slit, Codewheel (Rotating Disc) and Photodiode IC. By using these four main components, the AEAS-72AA-xxxAA is able to produce signals in either binary or gray output form. These signals provide to the designer a unique code for each position that the codewheel is in.

As seen in the diagram, the encoder contains a single Light Emitting Diode (LED) as its light source.

The light is collimated into a parallel beam by means of a lens which is built into the LED housing. This parallel beam goes through the Fixed Slit that creates a certain light pattern, due to its pattern of slots, which will fall onto the code-wheel. The movement of the code-wheel between LED and Photo detector, causes the light pattern (from the Fixed Slit) to be further interrupted by the pattern of spaces and bars on the codewheel. This final light pattern from the codewheel is then detected by the Photodiode IC where its signals are fed through signal processing circuitry to produce 8 or 10 parallel signals in binary or gray output form.

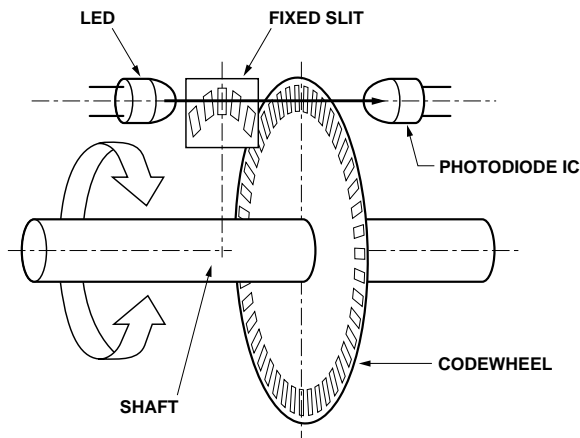

### Absolute Maximum Ratings

Storage Temperature	-25°C to 80°C
Operating Temperature	-10°C to 55°C
Supply Voltage	DC4.5 V to 13.2 V (for output mode = V) DC4.5 V to 13.2 V; DC10.8 V to 26.4 V (for output mode = C) (note: V <sub>CC</sub> ripple at 3% p-p max.)
Humidity	RH85%
Degree of Protection	(IP50): Protected against dust-limited ingress (no-harmful deposit) and no protection against liquids.
Shock	490 m/s <sup>2</sup> with 11ms at X, Y, Z directions

### Electrical Characteristics (over recommended operating conditions. Typically at 25°C)

Parameter	Symbol	Maximum	Units
Current Consumption (without load)	I <sub>CC</sub>	160m (max.) for option V 100m (max.) for option C	A
High Level Output Voltage	V <sub>OH</sub>	V <sub>CC</sub> - 1 V (for output mode = V)	V
Low Level Output Voltage	V <sub>OL</sub>	0.5 or less	V
Rise Time	t <sub>r</sub>	1	μs
Fall Time	t <sub>f</sub>	1	μs
Response Frequency	f	5K (max.)	Hz
Angular Accuracy		±0.700° (max.)	deg

### Mechanical Ratings

Parameter		Maximum	Units
Starting Torque		9.8 x 10 <sup>-4</sup> (max. at 25°C)	Nm
Angular Acceleration		1 x 10 <sup>5</sup>	rad/s <sup>2</sup>
Shaft Loading	Axial Thrust	19.6	N
	Radial	29.4	N
Moment of Inertia		8 x 10 <sup>-7</sup>	Kg.cm <sup>2</sup>
Speed		6000	RPM
Net-Weight (without cable)		120	g
Vibration (in X, Y, Z directions for 2 hrs.)		10 to 55	Hz/1.5 mm (p-p)

# Electrical Interface

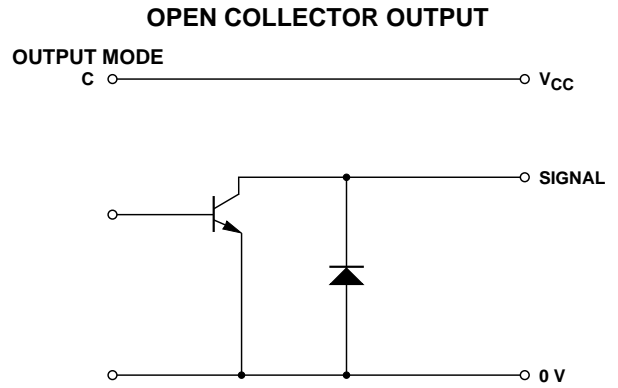
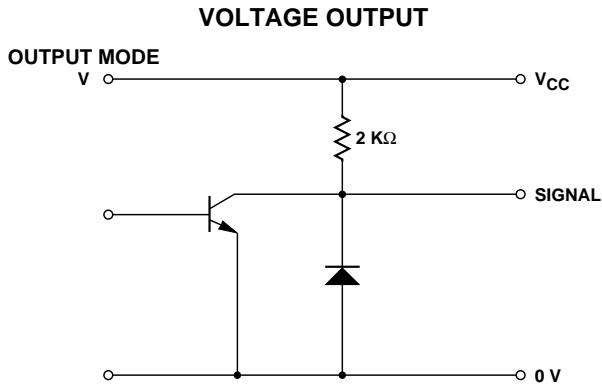

## Output Waveforms Definition

Signals are extracted by rotating the shaft in clockwise direction as viewed from arrow angle.

The example signals shown are gray code output.

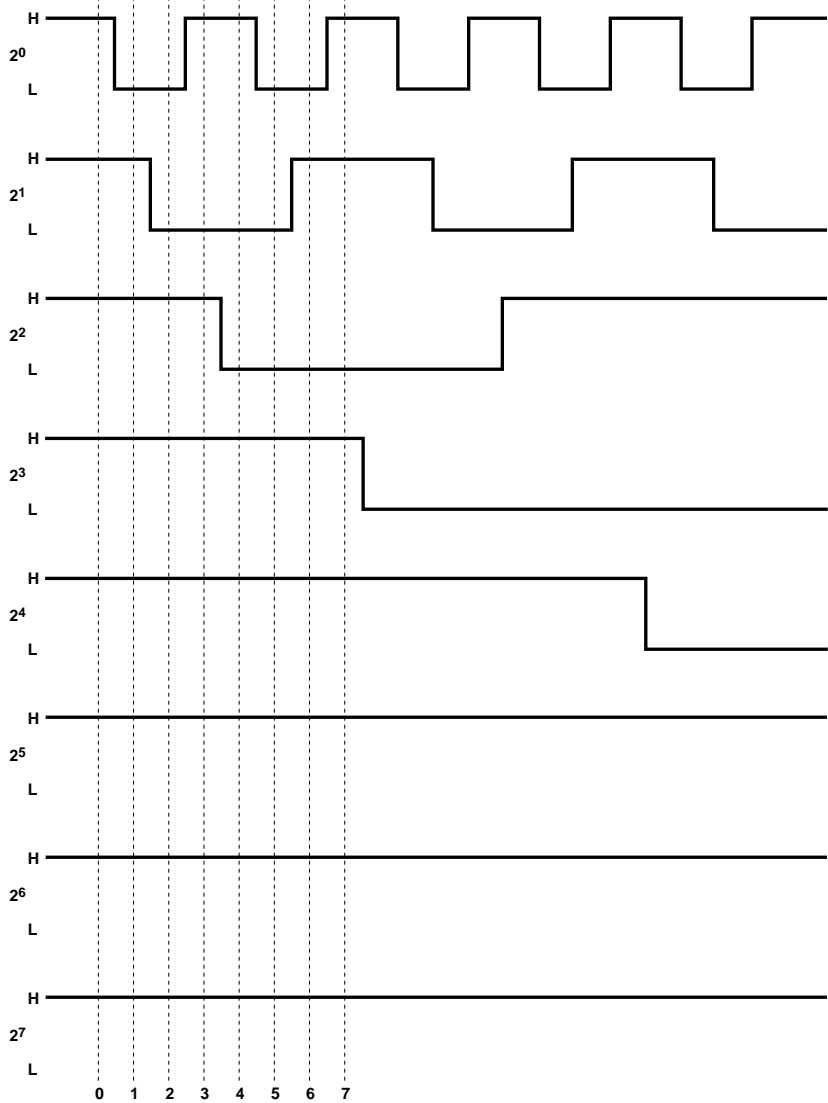
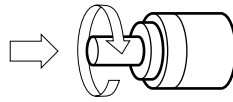

## Electrical Connections

Color of Lead Wire	Description
Red	Power Source
Black	0 V Common
Brown	Signal 2 <sup>0</sup>
Orange	Signal 2 <sup>1</sup>
Yellow	Signal 2 <sup>2</sup>
Green	Signal 2 <sup>3</sup>
Blue	Signal 2 <sup>4</sup>
Purple	Signal 2 <sup>5</sup>
Gray	Signal 2 <sup>6</sup>
White	Signal 2 <sup>7</sup>
Shielding Braid	F.G.

## Ordering Information

AEAS-72AA-□□□ AA

### Power Source

L = 5 to 12 V  
H = 12 to 24 V

### Output Code

G = Gray Code Negative Logic

### Output Mode

C = Open Collector  
V = Voltage Out, only available  
for option L of power source  
(5 to 12 V)

## Part Numbers Currently Available:

AEAS-72AA-HGCAA

AEAS-72AA-LGCAA

AEAS-72AA-LGVAA

**Note:** Please contact your local Agilent sales representative for other options.

**[www.agilent.com/semiconductors](http://www.agilent.com/semiconductors)**

For product information and a complete list of distributors, please go to our web site.

For technical assistance call:

Americas/Canada: +1 (800) 235-0312 or (408) 654-8675

Europe: +49 (0) 6441 92460

China: 10800 650 0017

Hong Kong: (+65) 6271 2451

India, Australia, New Zealand: (+65) 6271 2394

Japan: (+81 3) 3335-8152(Domestic/International), or 0120-61-1280(Domestic Only)

Korea: (+65) 6271 2194

Malaysia, Singapore: (+65) 6271 2054

Taiwan: (+65) 6271 2654

Data subject to change.

Copyright © 2003 Agilent Technologies, Inc.

Obsoletes 5988-8180EN

February 10, 2003

5988-8669EN



**Agilent Technologies**



LittleDiode supplies new, hard to find or obsolete electronic components and semiconductors all over the world.

With over two million different components listed you are sure to find the part you need.

Feel free to visit us today at our online store:

[LittleDiode.com](http://LittleDiode.com)

Looking forward to providing you with the best possible service.