

# Circuit protection elements

## ●Circuit protection elements

Rohm's circuit protectors have a very reliable current cut-off capability that protects ICs and their circuits from accidental short circuit loads. Whether operated in AC or DC circuits, these circuit protectors have a very low internal resistance in normal operation, but safely and rapidly break the circuit when the current cutoff level is exceeded.

## ●Features

- 1) Cutoff is sharp and repeatable.
- 2) Low internal resistance and minimal voltage drop.
- 3) Incombustible.
- 4) Compact.
- 5) Rated for continuous use.
- 6) Good temperature characteristics.
- 7) Withstands surges well.
- 8) UL certified (UL certification number E107856).

## ●Application

Current surge protection

## ●Operation notes

Do not use this product on the primary side of commercial power supplies. Arcs that result after cutoff may damage the molding.

## Surface mounting Type

### ●ICP-S series

Product name	Rated current (A)	Cutoff characteristics	Internal resistance Typ.( $\Omega$ )	Rated voltage (V)	Operating temperature ( $^{\circ}\text{C}$ )	Storage temperature ( $^{\circ}\text{C}$ )
ICP-S0.5	0.5	Fig.1	0.150	50	-55~+125	-55~+125
ICP-S0.7	0.7	Fig.2	0.084			
ICP-S1.0	1.0	Fig.3	0.061			
ICP-S1.2	1.2	Fig.4	0.048			
ICP-S1.8	1.8	Fig.5	0.032			
ICP-S2.3	2.3	Fig.6	0.026			

Transistors

●Cutoff characteristics

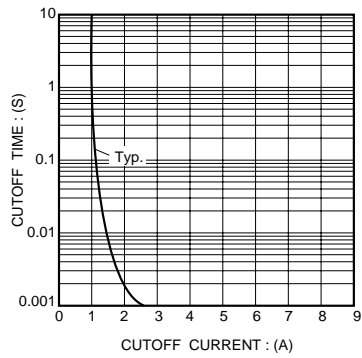

Fig.1 ICP-S0.5

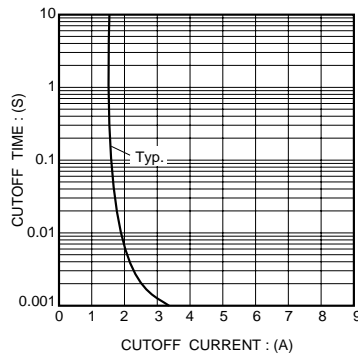

Fig.2 ICP-S0.7

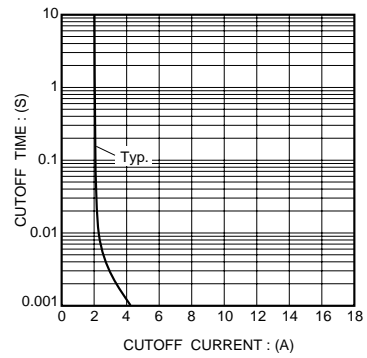

Fig.3 ICP-S1.0

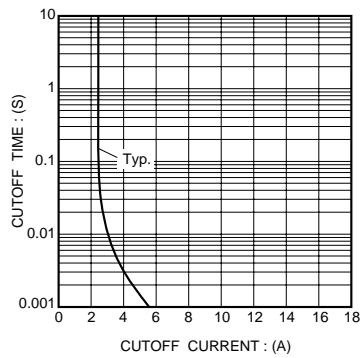

Fig.4 ICP-S1.2

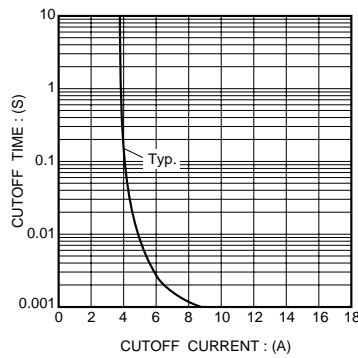

Fig.5 ICP-S1.8

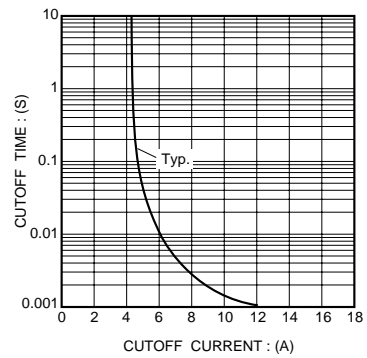
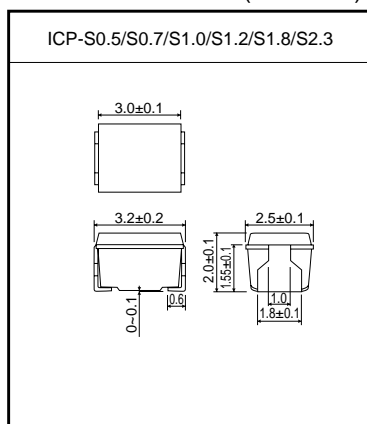

Fig.6 ICP-S2.3

The cutoff characteristics shown are typical. For further details of how to use these protectors, please request the technical documentation from your Rohm representative.

●External dimensions (Units : mm)





# Leaded type

ICP-N series

Product name	Rated current (A)	Cutoff characteristics	Internal resistance Typ.( $\Omega$ )	Rated voltage (V)	Operating temperature ( $^{\circ}\text{C}$ )	Storage temperature( $^{\circ}\text{C}$ )
ICP-N10	0.4	Fig.1	0.220	50	-55~+125	-55~+125
ICP-N15	0.6	Fig.2	0.135			
ICP-N20	0.8	Fig.3	0.100			
ICP-N25	1.0	Fig.4	0.070			
ICP-N38	1.5	Fig.5	0.042			
ICP-N50	2.0	Fig.6	0.035			
ICP-N70	2.5	Fig.7	0.023			

●Cutoff characteristics

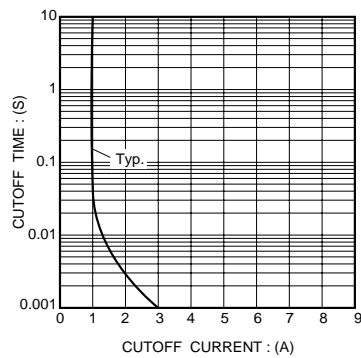

Fig.1 ICP-N10

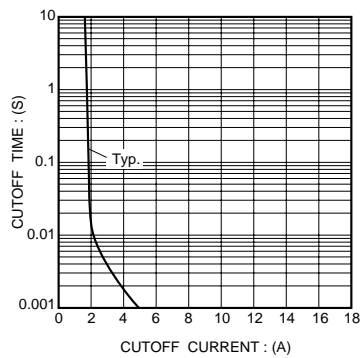

Fig.2 ICP-N15

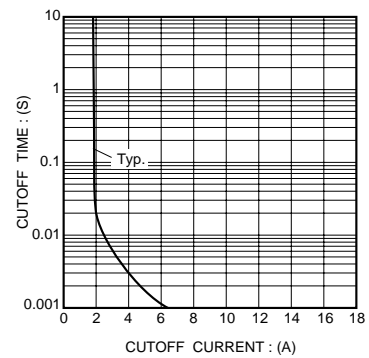

Fig.3 ICP-N20

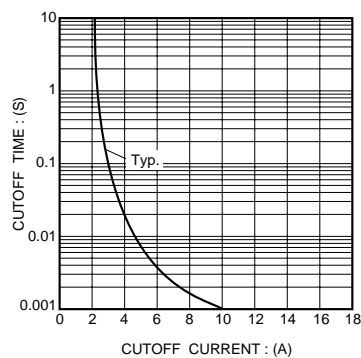

Fig.4 ICP-N25

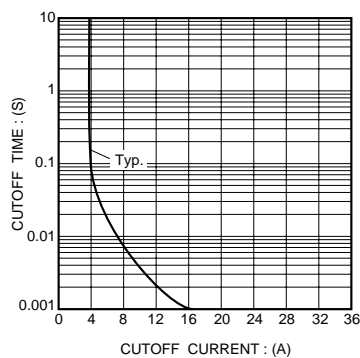

Fig.5 ICP-N38

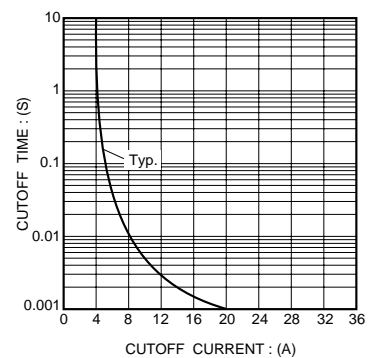

Fig.6 ICP-N50

Transistors

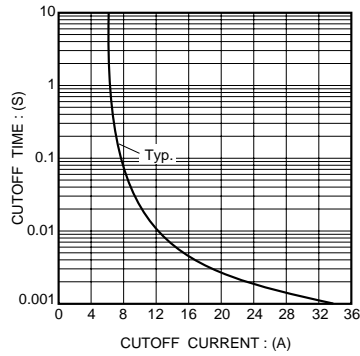
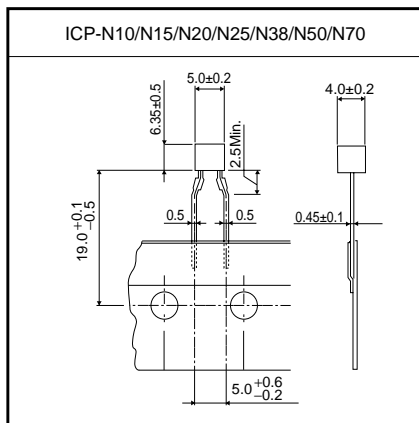

Fig.7 ICP-N70

The cutoff characteristics given represent typical values. Technical documentation regarding ways of using circuit protectors is available from your Rohm representative.

●External dimensions (Units : mm)



●Packaging specifications

ICP-N	Packaging type	Taping
	Symbol	T104
Type	Basic ordering unit (pieces)	3000
ICP-N10/N15/N20/N25/N38/N50/N70		○

●Taping specifications (Units : mm)

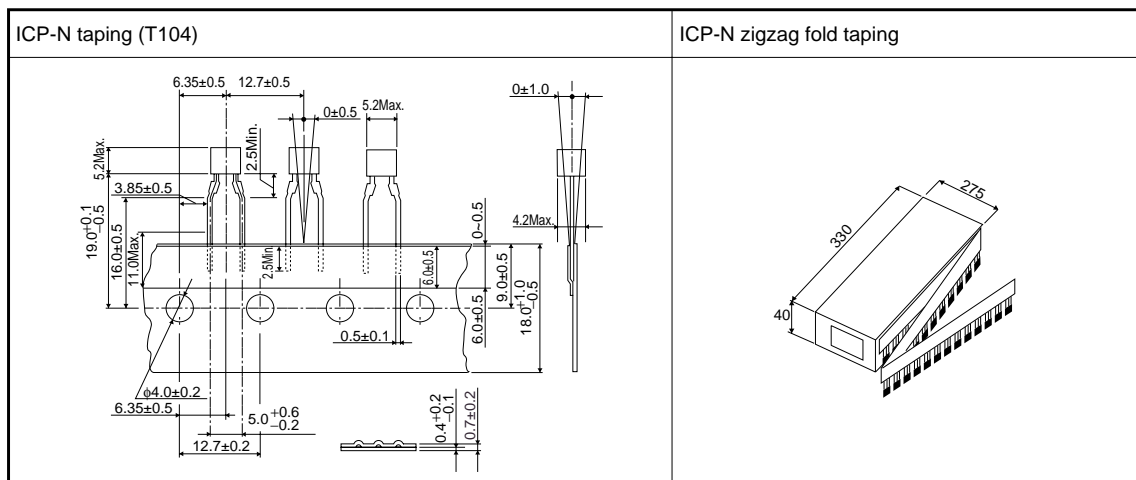



LittleDiode supplies new, hard to find or obsolete electronic components and semiconductors all over the world.

With over two million different components listed you are sure to find the part you need.

Feel free to visit us today at our online store:

**[LittleDiode.com](http://LittleDiode.com)**

Looking forward to providing you with the best possible service.