



1-MBIT (128K x 8) BOOT BLOCK FLASH MEMORY

28F001BX-T/28F001BX-B/28F001BN-T/28F001BN-B

- **High-Integration Blocked Architecture**
 - One 8 KB Boot Block w/Lock Out
 - Two 4 KB Parameter Blocks
 - One 112 KB Main Block
- **100,000 Erase/Program Cycles Per Block**
- **Simplified Program and Erase**
 - Automated Algorithms via On-Chip Write State Machine (WSM)
- **SRAM-Compatible Write Interface**
- **Deep Power-Down Mode**
 - 0.05 μA I_{CC} Typical
 - 0.8 μA I_{PP} Typical
- **12.0V \pm 5% V_{PP}**
- **High-Performance Read**
 - 70/75 ns, 90 ns, 120 ns, 150 ns Maximum Access Time
 - 5.0V \pm 10% V_{CC}
- **Hardware Data Protection Feature**
 - Erase/Write Lockout during Power Transitions
- **Advanced Packaging, JEDEC Pinouts**
 - 32-Pin PDIP
 - 32-Lead PLCC, TSOP
- **ETOX™ II Nonvolatile Flash Technology**
 - EPROM-Compatible Process Base
 - High-Volume Manufacturing Experience
- **Extended Temperature Options**

Intel's 28F001BX-B and 28F001BX-T combine the cost-effectiveness of Intel standard flash memory with features that simplify write and allow block erase. These devices aid the system designer by combining the functions of several components into one, making boot block flash an innovative alternative to EPROM and EEPROM or battery-backed static RAM. Many new and existing designs can take advantage of the 28F001BX's integration of blocked architecture, automated electrical reprogramming, and standard processor interface.

The 28F001BX-B and 28F001BX-T are 1,048,576 bit nonvolatile memories organized as 131,072 bytes of 8 bits. They are offered in 32-pin plastic DIP, 32-lead PLCC and 32-lead TSOP packages. Pin assignment conform to JEDEC standards for byte-wide EPROMs. These devices use an integrated command port and state machine for simplified block erasure and byte reprogramming. The 28F001BX-T's block locations provide compatibility with microprocessors and microcontrollers that boot from high memory, such as Intel's MCS®-186 family, 80286, i386™, i486™, i860™ and 80960CA. With exactly the same memory segmentation, the 28F001BX-B memory map is tailored for microprocessors and microcontrollers that boot from low memory, such as Intel's MCS-51, MCS-196, 80960KX and 80960SX families. All other features are identical, and unless otherwise noted, the term 28F001BX can refer to either device throughout the remainder of this document.

The boot block section includes a reprogramming write lock out feature to guarantee data integrity. It is designed to contain secure code which will bring up the system minimally and download code to the other locations of the 28F001BX. Intel's 28F001BX employs advanced CMOS circuitry for systems requiring high-performance access speeds, low power consumption, and immunity to noise. Its access time provides no-WAIT-state performance for a wide range of microprocessors and microcontrollers. A deep-powerdown mode lowers power consumption to 0.25 μW typical through V_{CC} , crucial in laptop computer, handheld instrumentation and other low-power applications. The RP# power control input also provides absolute data protection during system powerup or power loss.

Manufactured on Intel's ETOX process base, the 28F001BX builds on years of EPROM experience to yield the highest levels of quality, reliability, and cost-effectiveness.

NOTE: The 28F001BN is equivalent to the 28F001BX.

*Other brands and names are the property of their respective owners.
Information in this document is provided in connection with Intel products. Intel assumes no liability whatsoever, including infringement of any patent or copyright, for sale and use of Intel products except as provided in Intel's Terms and Conditions of Sale for such products. Intel retains the right to make changes to these specifications at any time, without notice. Microcomputer Products may have minor variations to this specification known as errata.
COPYRIGHT © INTEL CORPORATION, 1995

November 1995

Order Number: 290406-007

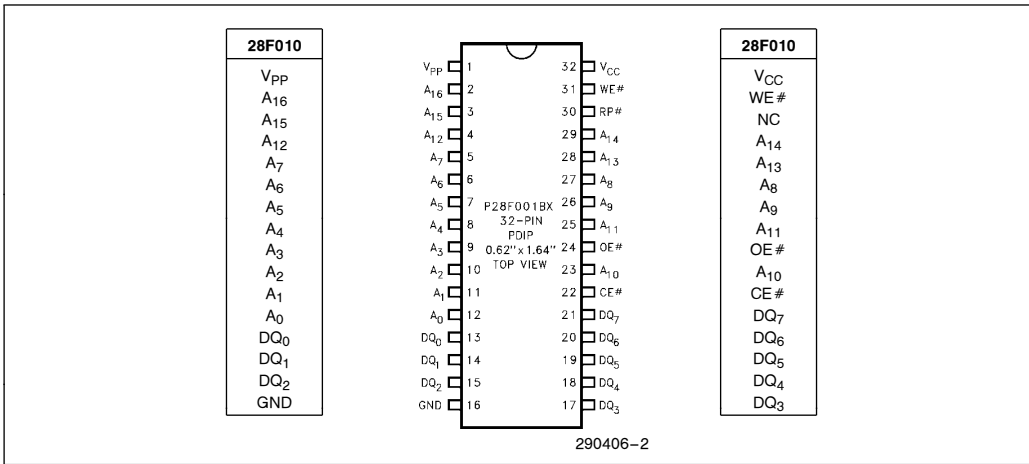

Figure 2. DIP Pin Configuration



Figure 3. TSOP Lead Configuration

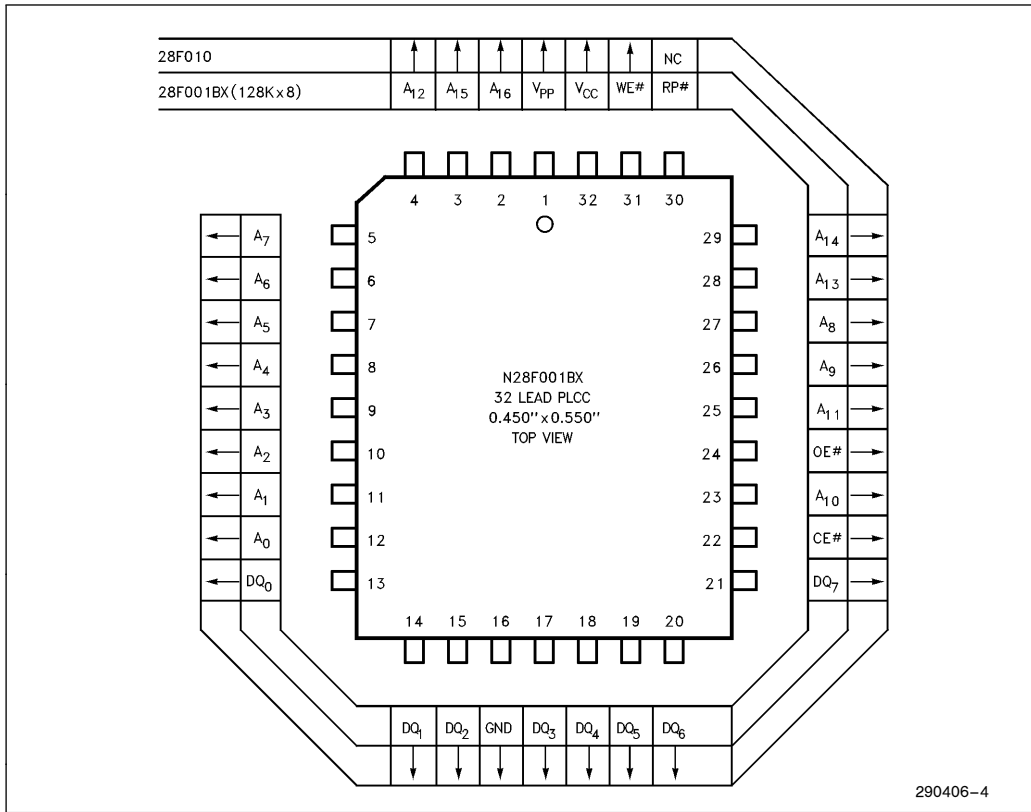

Figure 4. PLCC Lead Configuration

APPLICATIONS

The 28F001BX flash ‘boot block’ memory augments the non-volatility, in-system electrical erasure and reprogrammability of Intel’s standard flash memory by offering four separately erasable blocks and integrating a state machine to control erase and program functions. The specialized blocking architecture and automated programming of the 28F001BX provide a full-function, non-volatile flash memory ideal for a wide range of applications, including PC boot/BIOS memory, minimum-chip embedded program memory and parametric data storage. The 28F001BX combines the safety of a hardware-protected 8-KByte boot block with the flexibility of three separately reprogrammable blocks (two 4-KByte parameter blocks and one 112-KByte code block) into one versatile, cost-effective flash memory. Additionally, reprogramming one block does not affect code stored in another block, ensuring data integrity.

The flexibility of flash memory reduces costs throughout the life cycle of a design. During the early stages of a system’s life, flash memory reduces prototype development and testing time, allowing the system designer to modify in-system software electrically versus manual removal of components. During production, flash memory provides flexible firmware for just-in-time configuration, reducing system inventory and eliminating unnecessary handling and less reliable socketed connections. Late in the life cycle, when software updates or code “bugs” are often unpredictable and costly, flash memory reduces update costs by allowing the manufacturers to send floppy updates versus a technician. Alternatively, remote updates over a communication link are possible at speeds up to 9600 baud due to flash memory’s fast programming time.

Reprogrammable environments, such as the personal computer, are ideal applications for the 28F001BX. The internal state machine provides SRAM-like timings for program and erasure, using the Command and Status Registers. The blocking scheme allows BIOS update in the main and parameter blocks, while still providing recovery code in the boot block in the unlikely event a power failure occurs during an update, or where BIOS code is corrupted. Parameter blocks also provide convenient configuration storage, backing up SRAM and battery configurations. EISA systems, for example, can store hardware configurations in a flash parameter block, reducing system SRAM.

Laptop BIOSs are becoming increasingly complex with the addition of power management software and extended system setup screens. BIOS code complexity increases the potential for code updates after the sale, but the compactness of laptop designs makes hardware updates very costly. Boot block flash memory provides an inexpensive update solution for laptops, while reducing laptop obsolescence. For portable PCs and hand-held equipment, the deep powerdown mode dramatically lowers sys-

tem power requirements during periods of slow operation or sleep modes.

The 28F001BX gives the embedded system designer several desired features. The internal state machine reduces the size of external code dedicated to the erase and program algorithms, as well as freeing the microcontroller or microprocessor to respond to other system requests during program and erasure. The four blocks allow logical segmentation of the entire embedded software: the 8-KByte block for the boot code, the 112-KByte block for the main program code and the two 4-KByte blocks for updatable parametric data storage, diagnostic messages and data, or extensions of either the boot code or program code. The boot block is hardware protected against unauthorized write or erase of its vital code in the field. Further, the powerdown mode also locks out erase or write operations, providing absolute data protection during system powerup or power loss. This hardware protection provides obvious advantages for safety related applications such as transportation, military, and medical. The 28F001BX is well suited for minimum-chip embedded applications ranging from communications to automotive.

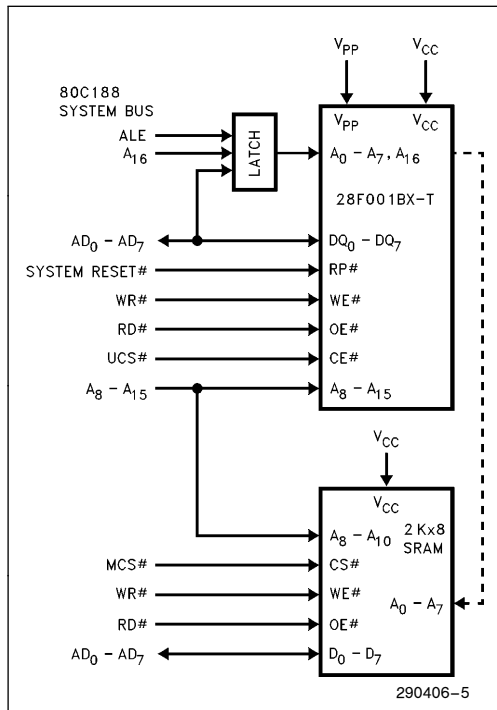

Figure 5. 28F001BX-T in a 80C188 System

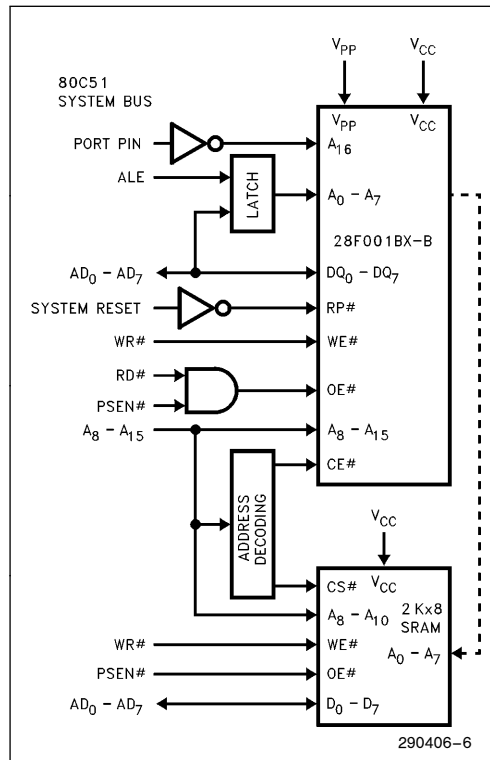

Figure 6. 28F001BX-B in a 80C51 System

PRINCIPLES OF OPERATION

The 28F001BX introduces on-chip write automation to manage write and erase functions. The write state machine allows for 100% TTL-level control inputs, fixed power supplies during erasure and programming, minimal processor overhead with RAM-like write timings, and maximum EPROM compatibility.

After initial device powerup, or after return from deep powerdown mode (see Bus Operations), the 28F001BX functions as a read-only memory. Manipulation of external memory-control pins yield standard EPROM read, standby, output disable or Intelligent Identifier operations. Both Status Register and Intelligent Identifiers can be accessed through the Command Register when $V_{PP} = V_{PPL}$.

This same subset of operations is also available when high voltage is applied to the V_{PP} pin. In addition, high voltage on V_{PP} enables successful erasure and programming of the device. All functions associated with altering memory contents—program, erase, status, and intelligent Identifier—are accessed via the Command Register and verified through the Status Register.

Commands are written using standard microprocessor write timings. Register contents serve as input to the WSM, which controls the erase and programming circuitry. Write cycles also internally latch addresses and data needed for programming or erase operations. With the appropriate command written to the register, standard microprocessor read timings output array data, access the intelligent identifier codes, or output program and erase status for verification.

Interface software to initiate and poll progress of internal program and erase can be stored in any of the 28F001BX blocks. This code is copied to, and executed from, system RAM during actual flash memory update. After successful completion of program and/or erase, code execution out of the 28F001BX is again possible via the Read Array command. Erase suspend/resume capability allows system software to suspend block erase and read data/execute code from any other block.

Command Register and Write Automation

An on-chip state machine controls block erase and byte program, freeing the system processor for other tasks. After receiving the erase setup and erase confirm commands, the state machine controls block pre-conditioning and erase, returning progress via the Status Register. Programming is similarly controlled, after destination address and expected data are supplied. The program algorithm of past Intel Flash Memories is now regulated by the state machine, including program pulse repetition where required and internal verification and margining of data.

Data Protection

Depending on the application, the system designer may choose to make the V_{PP} power supply switchable (available only when memory updates are required) or hardwired to V_{PPH} . When $V_{PP} = V_{PPL}$, memory contents cannot be altered. The 28F001BX Command Register architecture provides protection from unwanted program or erase operations even when high voltage is applied to V_{PP} . Additionally, all functions are disabled whenever V_{CC} is below the write lockout voltage V_{LKO} , or when $RP\#$ is at V_{IL} . The 28F001BX accommodates either design practice and encourages optimization of the processor-memory interface.

The two-step program/erase write sequence to the Command Register provides additional software write protection.

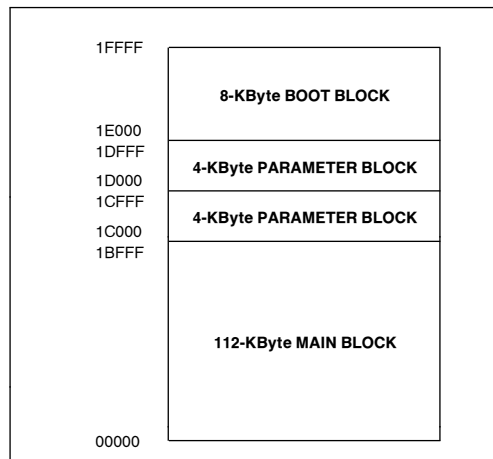

Figure 7. 28F001BX-T Memory Map

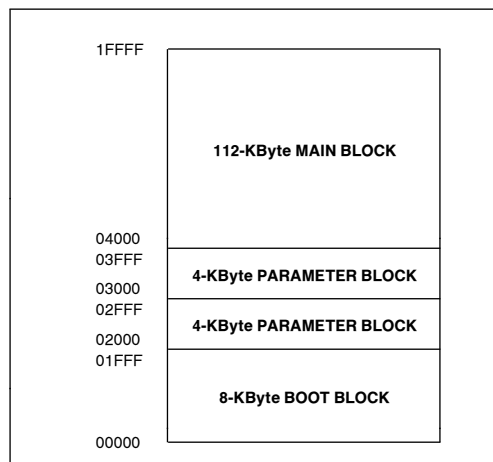

Figure 8. 28F001BX-B Memory Map

BUS OPERATION

Flash memory reads, erases and writes in-system via the local CPU. All bus cycles to or from the flash memory conform to standard microprocessor bus cycles.

Read

The 28F001BX has three read modes. The memory can be read from any of its blocks, and information can be read from the Intelligent Identifier or the Status Register. V_{PP} can be at either V_{PPL} or V_{PPH} .

The first task is to write the appropriate read mode command to the Command Register (array, Intelligent Identifier, or Status Register). The 28F001BX automatically resets to Read Array mode upon initial device powerup or after exit from deep powerdown. The 28F001BX has four control pins, two of which must be logically active to obtain data at the outputs. Chip Enable ($CE\#$) is the device selection control, and when active enables the selected memory device. Output Enable ($OE\#$) is the data input/output (DQ_0 – DQ_7) direction control, and when active drives data from the selected memory onto the I/O bus. $RP\#$ and $WE\#$ must also be at V_{IH} . Figure 12 illustrates read bus cycle waveforms.

Output Disable

With $OE\#$ at a logic-high level (V_{IH}), the device outputs are disabled. Output pins (DQ_0 – DQ_7) are placed in a high-impedance state.

Standby

$CE\#$ at a logic-high level (V_{IH}) places the 28F001BX in standby mode. Standby operation disables much of the 28F001BX's circuitry and substantially reduces device power consumption. The outputs (DQ_0 – DQ_7) are placed in a high-impedance state independent of the status of $OE\#$. If the 28F001BX is deselected during erase or program, the device will continue functioning and consuming normal active power until the operation is completed.

Deep Power-Down

The 28F001BX offers a 0.25 μW V_{CC} power-down feature, entered when $RP\#$ is at V_{IL} . During read modes, $RP\#$ low deselects the memory, places output drivers in a high-impedance state and turns off all internal circuits. The 28F001BX requires time t_{PHQV} (see AC Characteristics-Read Only Operations) after return from power-down until initial memory access outputs are valid. After this wakeup interval, normal operation is restored. The Command Register is reset to Read Array, and the Status Register is cleared to value 80H, upon return to normal operation.

During erase or program modes, $RP\#$ low will abort either operation. Memory contents of the block being altered are no longer valid as the data will be partially programmed or erased. Time t_{PHWL} after $RP\#$ goes to logic-high (V_{IH}) is required before another command can be written.

Table 2. 28F001BX Bus Operations

Mode	Notes	$RP\#$	$CE\#$	$OE\#$	$WE\#$	A_9	A_0	V_{PP}	DQ_0 – 7
Read	1, 2, 3	V_{IH}	V_{IL}	V_{IL}	V_{IH}	X	X	X	D_{OUT}
Output Disable	2	V_{IH}	V_{IL}	V_{IH}	V_{IH}	X	X	X	High Z
Standby	2	V_{IH}	V_{IH}	X	X	X	X	X	High Z
Deep Power Down	2	V_{IL}	X	X	X	X	X	X	High Z
Intelligent Identifier (Mfr)	2, 3, 4	V_{IH}	V_{IL}	V_{IL}	V_{IH}	V_{ID}	V_{IL}	X	89H
Intelligent Identifier (Device)	2, 3, 4, 5	V_{IH}	V_{IL}	V_{IL}	V_{IH}	V_{ID}	V_{IH}	X	94H, 95H
Write	2, 6, 7, 8	V_{IH}	V_{IL}	V_{IH}	V_{IL}	X	X	X	D_{IN}

NOTES:

1. Refer to DC Characteristics. When $V_{PP} = V_{PPL}$, memory contents can be read but not programmed or erased.
2. X can be V_{IL} or V_{IH} for control pins and addresses, and V_{PPL} or V_{PPH} for V_{PP} .
3. See DC Characteristics for V_{PPL} , V_{PPH} , V_{HH} and V_{ID} voltages.
4. Manufacturer and device codes may also be accessed via a Command Register write sequence. Refer to Table 3. A_1 – A_8 , A_{10} – $A_{16} = V_{IL}$.
5. Device ID = 94H for the 28F001BX-T and 95H for the 28F001BX-B.
6. Command writes involving block erase or byte program are successfully executed only when $V_{PP} = V_{PPH}$.
7. Refer to Table 3 for valid D_{IN} during a write operation.
8. Program or erase the boot block by holding $RP\#$ at V_{HH} or toggling $OE\#$ to V_{HH} . See AC Waveforms for program/erase operations.

The use of RP# during system reset is important with automated write/erase devices. When the system comes out of reset it expects to read from the flash memory. Automated flash memories provide status information when accessed during write/erase modes. If a CPU reset occurs with no flash memory reset, proper CPU initialization would not occur because the flash memory would be providing the status information instead of array data. Intel's Flash Memories allow proper CPU initialization following a system reset through the use of the RP# input. In this application RP# is controlled by the same RESET# signal that resets the system CPU.

Intelligent Identifier Operation

The Intelligent Identifier operation outputs the manufacturer code, 89H; and the device code, 94H for the 28F001BX-T and 95H for the 28F001BX-B. Programming equipment or the system CPU can then automatically match the device with its proper erase and programming algorithms.

PROGRAMMING EQUIPMENT

CE# and OE# at a logic low level (V_{IL}), with A_9 at high voltage V_{ID} (see DC Characteristics) activates this operation. Data read from locations 00000H and 00001H represent the manufacturer's code and the device code respectively.

IN-SYSTEM PROGRAMMING

The manufacturer- and device-codes can also be read via the Command Register. Following a write of 90H to the Command Register, a read from address location 00000H outputs the manufacturer code (89H). A read from address 00001H outputs the device code (94H for the 28F001BX-T and 95H for the 28F001BX-B). It is not necessary to have high voltage applied to V_{PP} to read the Intelligent Identifiers from the Command Register.

Write

Writes to the Command Register allow read of device data and Intelligent Identifiers. They also control inspection and clearing of the Status Register. Additionally, when $V_{PP} = V_{PPH}$, the Command Register controls device erasure and programming. The contents of the register serve as input to the internal state machine.

The Command Register itself does not occupy an addressable memory location. The register is a latch used to store the command and address and data information needed to execute the command. Erase

Setup and Erase Confirm commands require both appropriate command data and an address within the block to be erased. The Program Setup Command requires both appropriate command data and the address of the location to be programmed, while the Program command consists of the data to be written and the address of the location to be programmed.

The Command Register is written by bringing WE# to a logic-low level (V_{IL}) while CE# is low. Addresses and data are latched on the rising edge of WE#. Standard microprocessor write timings are used.

Refer to AC Write Characteristics and the AC Waveform for Write Operations, Figure 13, for specific timing parameters.

COMMAND DEFINITIONS

When V_{PPL} is applied to the V_{PP} pin, read operations from the Status Register, intelligent identifiers, or array blocks are enabled. Placing V_{PPH} on V_{PP} enables successful program and erase operations as well.

Device operations are selected by writing specific commands into the Command Register. Table 3 defines these 28F001BX commands.

Read Array Command

Upon initial device powerup and after exit from deep-powerdown mode, the 28F001BX defaults to Read Array mode. This operation is also initiated by writing FFH into the Command Register. Microprocessor read cycles retrieve array data. The device remains enabled for reads until the Command Register contents are altered. Once the internal write state machine has started an erase or program operation, the device will not recognize the Read Array command, until the WSM has completed its operation. The Read Array command is functional when $V_{PP} = V_{PPL}$ or V_{PPH} .

Intelligent Identifier Command for In-System Programming

The 28F001BX contains an Intelligent Identifier operation to supplement traditional PROM-programming methodology. The operation is initiated by writing 90H into the Command Register. Following the command write, a read cycle from address 00000H retrieves the manufacturer code of 89H. A read cycle from address 00001H returns the device code of 94H (28F001BX-T) or 95H (28F001BX-B). To terminate the operation, it is necessary to write another valid command into the register. Like the Read Array command, the Intelligent Identifier command is functional when $V_{PP} = V_{PPL}$ or V_{PPH} .

Table 3. 28F001BX Command Definitions

Command	Bus Cycles Req'd	Notes	First Bus Cycle			Second Bus Cycle		
			Operation	Address	Data	Operation	Address	Data
Read Array/Reset	1	1	Write	X	FFH			
Intelligent Identifier	3	2, 3, 4	Write	X	90H	Read	IA	IID
Read Status Register	2	3	Write	X	70H	Read	X	SRD
Clear Status Register	1		Write	X	50H			
Erase Setup/Erase Confirm	2	2	Write	BA	20H	Write	BA	D0H
Erase Suspend/Erase Resume	2		Write	X	B0H	Write	X	D0H
Program Setup/Program	2	2, 3	Write	PA	40H	Write	PA	PD

NOTES:

1. Bus operations are defined in Table 2.
2. IA = Identifier Address: 00H for manufacturer code, 01H for device code.
BA = Address within the block being erased.
PA = Address of memory location to be programmed.
3. SRD = Data read from Status Register. See Table 4 for a description of the Status Register bits.
PD = Data to be programmed at location PA. Data is latched on the rising edge of WE#.
IID = Data read from Intelligent Identifiers.
4. Following the Intelligent Identifier command, two read operations access manufacture and device codes.
5. Commands other than those shown above are reserved by Intel for future device implementations and should not be used.

Read Status Register Command

The 28F001BX contains a Status Register which may be read to determine when a program or erase operation is complete, and whether that operation completed successfully. The Status Register may be read at any time by writing the Read Status Register command (70H) to the Command Register. After writing this command, all subsequent read operations output data from the Status Register, until another valid command is written to the Command Register. The contents of the Status Register are latched on the falling edge of OE# or CE#, whichever occurs last in the read cycle. OE# or CE# must be toggled to V_{IH} before further reads to update the Status Register latch. The Read Status Register command functions when V_{PP} = V_{PPL} or V_{PPH}.

reset by the Clear Status Register command. These bits indicate various failure conditions (see Table 4). By allowing system software to control the resetting of these bits, several operations may be performed (such as cumulatively programming several bytes or erasing multiple blocks in sequence). The Status Register may then be polled to determine if an error occurred during that series. This adds flexibility to the way the device may be used.

Additionally, the V_{PP} Status bit (SR.3), when set to "1", MUST be reset by system software before further byte programs or block erases are attempted. To clear the Status Register, the Clear Status Register command (50H) is written to the Command Register. The Clear Status Register command is functional when V_{PP} = V_{PPL} or V_{PPH}.

Clear Status Register Command

The Erase Status and Program Status bits are set to "1" by the Write State Machine and can only be

Table 4. 28F001BX Status Register Definitions

WSMS	ESS	ES	PS	VPPS	R	R	R	
7	6	5	4	3	2	1	0	
SR.7 = WRITE STATE MACHINE STATUS 1 = Ready 0 = Busy				NOTES: The Write State Machine Status Bit must first be checked to determine program or erase completion, before the Program or Erase Status bits are checked for success.				
SR.6 = ERASE SUSPEND STATUS 1 = Erase Suspended 0 = Erase In Progress/Completed				If the Program AND Erase Status bits are set to "1s" during an erase attempt, an improper command sequence was entered. Attempt the operation again.				
SR.5 = ERASE STATUS 1 = Error in Block Erasure 0 = Successful Block Erase				If V _{PP} low status is detected, the Status Register must be cleared before another program or erase operation is attempted.				
SR.4 = PROGRAM STATUS 1 = Error in Byte Program 0 = Successful Byte Program				The V _{PP} Status bit, unlike an A/D converter, does not provide continuous indication of V _{PP} level. The WSM interrogates the V _{PP} level only after the program or erase command sequences have been entered and informs the system if V _{PP} has not been switched on. The V _{PP} Status bit is not guaranteed to report accurate feedback between V _{PP} L and V _{PP} H.				
SR.3 = V _{PP} STATUS 1 = V _{PP} Low Detect; Operation Abort 0 = V _{PP} OK								
SR.2-SR.0 = RESERVED FOR FUTURE ENHANCEMENTS These bits are reserved for future use and should be masked out when polling the Status Register.								

Erase Setup/Erase Confirm Commands

Erase is executed one block at a time, initiated by a two-cycle command sequence. An Erase Setup command (20H) is first written to the Command Register, followed by the Erase Confirm command (D0H). These commands require both appropriate command data and an address within the block to be erased. Block preconditioning, erase and verify are all handled internally by the Write State Machine, invisible to the system. After receiving the two-command erase sequence, the 28F001BX automatically outputs Status Register data when read (see Figure 10; Block Erase Flowchart). The CPU can detect the completion of the erase event by checking the WSM Status bit of the Status Register (SR.7).

When the Status Register indicates that erase is complete, the Erase Status bit should be checked. If erase error is detected, the Status Register should be cleared. The Command Register remains in Read Status Register Mode until further commands are issued to it.

This two-step sequence of set-up followed by execution ensures that memory contents are not accidentally erased. Also, block erasure can only occur when V_{PP} = V_{PP}H. In the absence of this high voltage, memory contents are protected against erasure. If block erase is attempted while V_{PP} = V_{PP}L,

the V_{PP} Status bit will be set to "1". Erase attempts while V_{PP}L < V_{PP} < V_{PP}H produce spurious results and should not be attempted.

Erase Suspend/Erase Resume Commands

The Erase Suspend Command allows erase sequence interruption in order to read data from another block of memory. Once the erase sequence is started, writing the Erase Suspend command (B0H) to the Command Register requests that the WSM suspend the erase sequence at a predetermined point in the erase algorithm. The 28F001BX continues to output Status Register data when read, after the Erase Suspend command is written to it. Polling the WSM Status and Erase Suspend Status bits will determine when the erase operation has been suspended (both will be set to "1s").

At this point, a Read Array command can be written to the Command Register to read data from blocks **other than that which is suspended**. The only other valid commands at this time are Read Status Register (70H) and Erase Resume (D0H), at which time the WSM will continue with the erase sequence. The Erase Suspend Status and WSM Status bits of the Status Register will be cleared. After the Erase Resume command is written to it, the 28F001BX automatically outputs Status Register data when read (see Figure 11; Erase Suspend/Resume Flowchart).

Program Setup/Program Commands

Programming is executed by a two-write sequence. The program Setup command (40H) is written to the Command Register, followed by a second write specifying the address and data (latched on the rising edge of WE#) to be programmed. The WSM then takes over, controlling the program and verify algorithms internally. After the two-command program sequence is written to it, the 28F001BX automatically outputs Status Register data when read (see Figure 9; Byte Program Flowchart). The CPU can detect the completion of the program event by analyzing the WSM Status bit of the Status Register. Only the Read Status Register command is valid while programming is active.

When the Status Register indicates that programming is complete, the Program Status bit should be checked. If program error is detected, the Status Register should be cleared. The internal WSM verify only detects errors for "1s" that do not successfully program to "0s". The Command Register remains in Read Status Register mode until further commands are issued to it. If byte program is attempted while $V_{PP} = V_{PPL}$, the V_{PP} Status bit will be set to "1". Program attempts while $V_{PPL} < V_{PP} < V_{PPH}$ produce spurious results and should not be attempted.

EXTENDED ERASE/PROGRAM CYCLING

EEPROM cycling failures have always concerned users. The high electrical field required by thin oxide EEPROMs for tunneling can literally tear apart the oxide at defect regions. To combat this, some suppliers have implemented redundancy schemes, reducing cycling failures to insignificant levels. However, redundancy requires that cell size be doubled; an expensive solution.

Intel has designed extended cycling capability into its ETOX flash memory technology. Resulting improvements in cycling reliability come without increasing memory cell size or complexity. First, an advanced tunnel oxide increases the charge carrying ability ten-fold. Second, the oxide area per cell subjected to the tunneling electrical field is one-tenth that of common EEPROMs, minimizing the probability of oxide defects in the region. Finally, the peak electric field during erasure is approximately 2 Mv/cm lower than EEPROM. The lower electric field greatly reduces oxide stress and the probability of failure.

The 28F001BX-B and 28F001BX-T are capable of 100,000 program/erase cycles on each parameter block, main block and boot block.

ON-CHIP PROGRAMMING ALGORITHM

The 28F001BX integrates the Quick Pulse programming algorithm of prior Intel Flash Memory devices on-chip, using the Command Register, Status Register and Write State Machine (WSM). On-chip integration dramatically simplifies system software and provides processor-like interface timings to the Command and Status Registers. WSM operation, internal program verify and V_{PP} high voltage presence are monitored and reported via appropriate Status Register bits. Figure 9 shows a system software flowchart for device programming. The entire sequence is performed with V_{PP} at V_{PPH} . Program abort occurs when RP# transitions to V_{IL} , or V_{PP} drops to V_{PPL} . Although the WSM is halted, byte data is partially programmed at the location where programming was aborted. Block erasure or a repeat of byte programming will initialize this data to a known value.

ON-CHIP ERASE ALGORITHM

As above, the Quick Erase algorithm of prior Intel Flash Memory devices is now implemented internally, including all preconditioning of block data. WSM operation, erase success and V_{PP} high voltage presence are monitored and reported through the Status Register. Additionally, if a command other than Erase Confirm is written to the device after Erase Setup has been written, both the Erase Status and Program Status bits will be set to "1". When issuing the Erase Setup and Erase Confirm commands, they should be written to an address within the address range of the block to be erased. Figure 10 shows a system software flowchart for block erase.

Erase typically takes 1–4 seconds per block. The Erase Suspend/Erase Resume command sequence allows interrupt of this erase operation to read data **from a block other than that in which erase is being performed**. A system software flowchart is shown in Figure 11.

The entire sequence is performed with V_{PP} at V_{PPH} . Abort occurs when RP# transitions to V_{IL} or V_{PP} falls to V_{PPL} , while erase is in progress. Block data is partially erased by this operation, and a repeat of erase is required to obtain a fully erased block.



BOOT BLOCK PROGRAM AND ERASE

The boot block is intended to contain secure code which will minimally bring up a system and control programming and erase of other blocks of the device, if needed. Therefore, additional “lockout” protection is provided to guarantee data integrity. Boot block program and erase operations are enabled through high voltage V_{HH} on either $RP\#$ or $OE\#$, and the normal program and erase command sequences are used. Reference the AC Waveforms for Program/Erase.

If boot block program or erase is attempted while $RP\#$ is at V_{IH} , either the Program Status or Erase Status bit will be set to “1”, reflective of the opera-

tion being attempted and indicating boot block lock. Program/erase attempts while $V_{IH} < RP\# < V_{HH}$ produce spurious results and should not be attempted.

In-System Operation

For on-board programming, the $RP\#$ pin is the most convenient means of altering the boot block. Before issuing Program or Erase confirms commands, $RP\#$ must transition to V_{HH} . Hold $RP\#$ at this high voltage throughout the program or erase interval (until after Status Register confirm of successful completion). At this time, it can return to V_{IH} or V_{IL} .

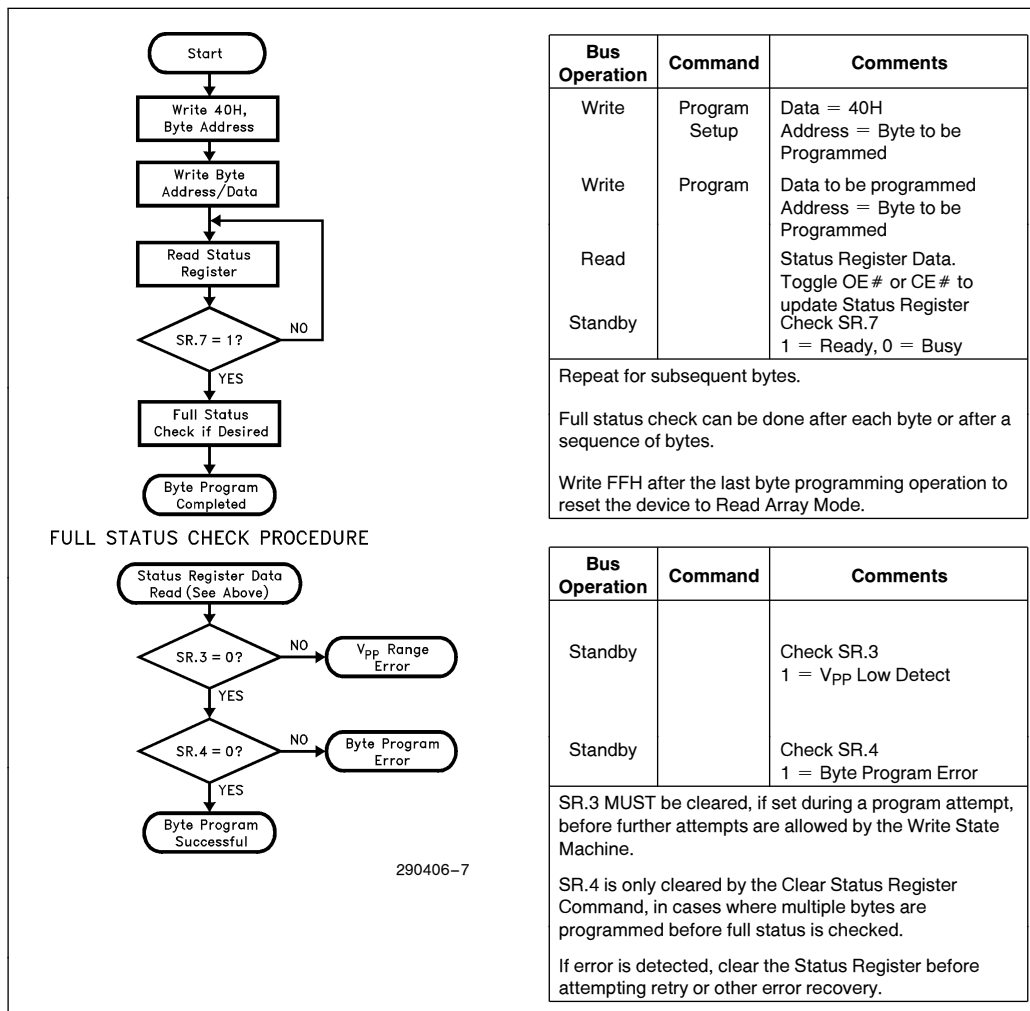

Figure 9. 28F001BX Byte Programming Flowchart

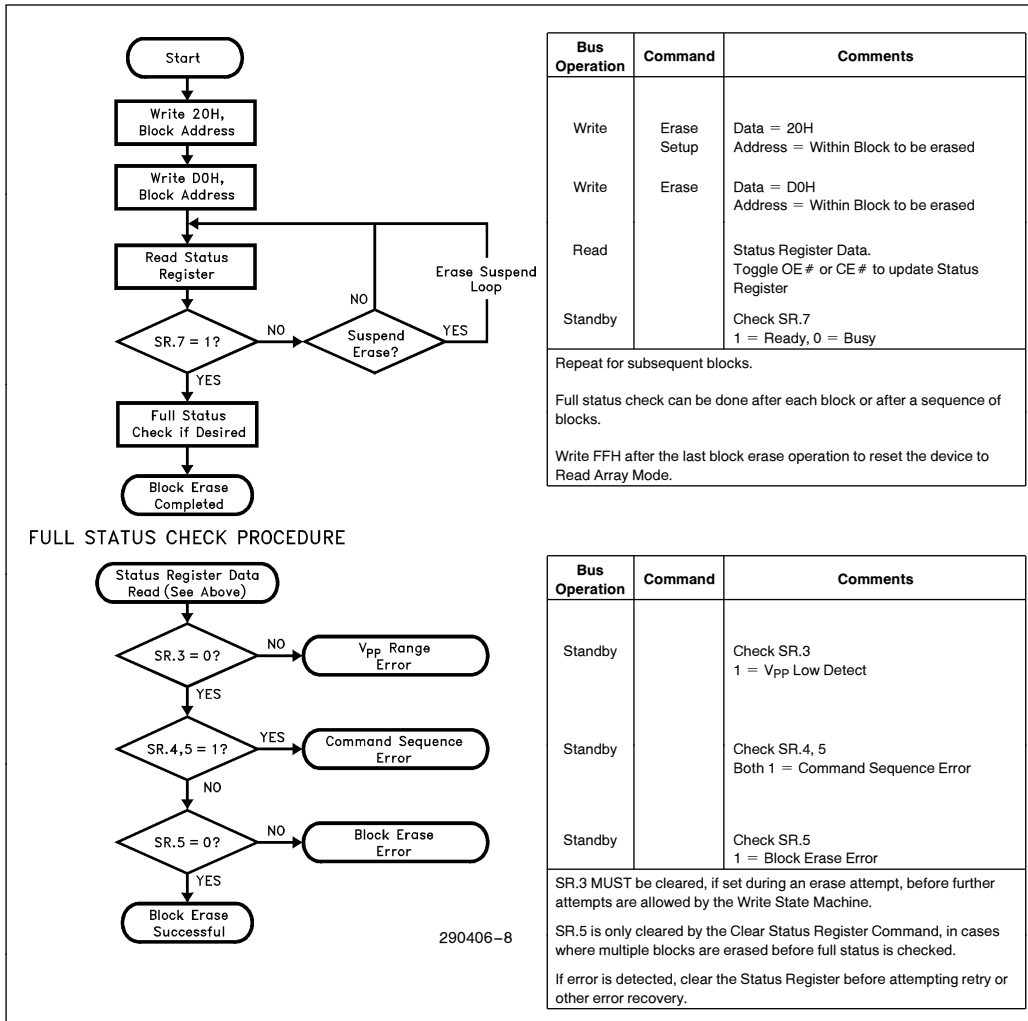

Figure 10. 28F001BX Block Erase Flowchart

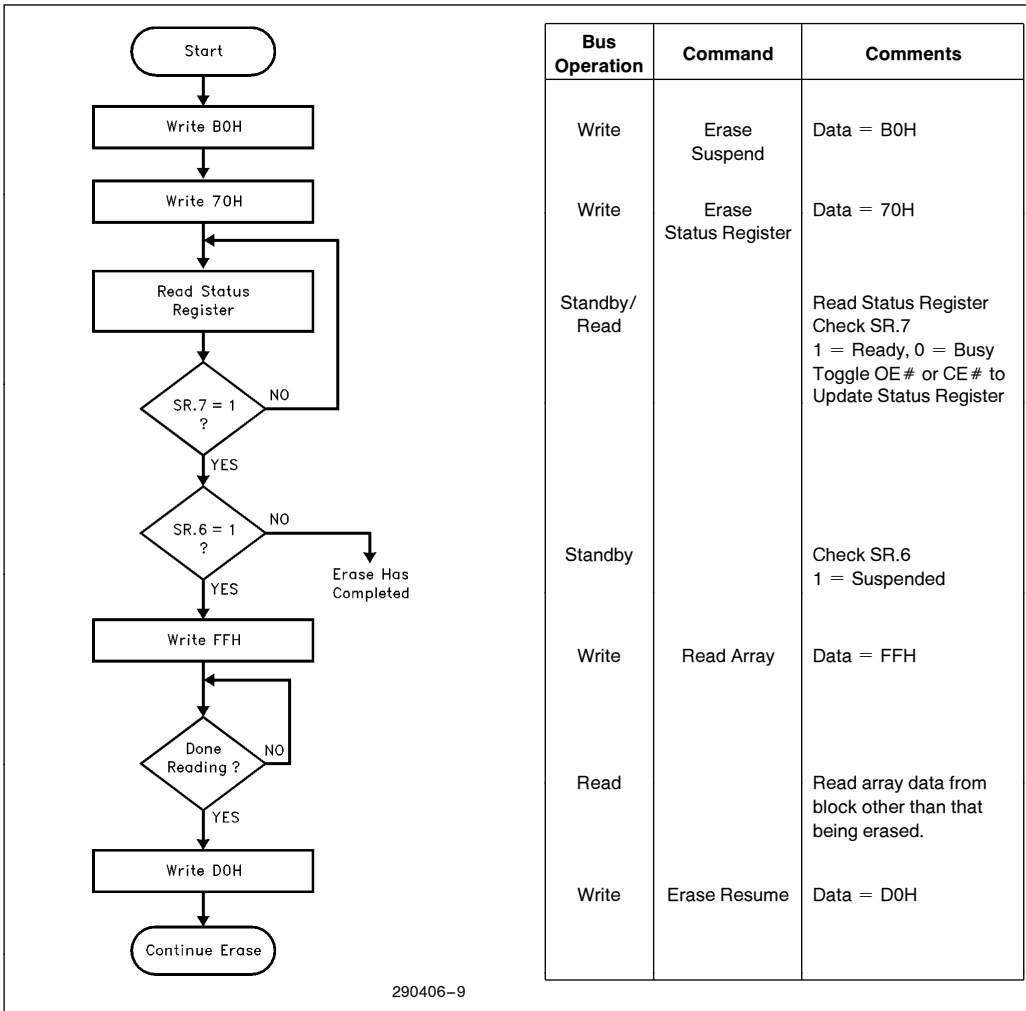

Figure 11. 28F001BX Erase Suspend/Resume Flowchart

Programming Equipment

For PROM programming equipment that cannot bring RP# to high voltage, OE# provides an alternate boot block access mechanism. OE# must transition to V_{HH} a minimum of 480 ns before the initial program/erase setup command and held at V_{HH} at least 480 ns after program or erase confirm commands are issued to the device. After this interval, OE# can return to normal TTL levels.

DESIGN CONSIDERATIONS

Three-Line Output Control

Flash memories are often used in larger memory arrays. Intel provides three control inputs to accommo-

date multiple memory connections. Three-line control provides for:

- a) lowest possible memory power dissipation
- b) complete assurance that data bus contention will not occur

To efficiently use these control inputs, an address decoder should enable CE#, while OE# should be connected to all memory devices and the system's READ# control line. This assures that only selected memory devices have active outputs while deselected memory devices are in Standby Mode. RP# should be connected to the system POWERGOOD signal to prevent unintended writes during system power transitions. POWERGOOD should also toggle during system reset.

Power Supply Decoupling

Flash memory power switching characteristics require careful device coupling. System designers are interested in 3 supply current issues; standby current levels (I_{SB}), active current levels (I_{CC}) and transient peaks produced by falling and rising edges of $CE\#$. Transient current magnitudes depend on the device outputs' capacitive and inductive loading. Two-line control and proper decoupling capacitor selection will suppress transient voltage peaks. Each device should have a 0.1 μ F ceramic capacitor connected between its V_{CC} and GND, and between its V_{PP} and GND. These high frequency, low inherent-inductance capacitors should be placed as close as possible to the device. Additionally, for every 8 devices, a 4.7 μ F electrolytic capacitor should be placed at the array's power supply connection between V_{CC} and GND. The bulk capacitor will overcome voltage slumps caused by PC board trace inductances.

V_{PP} Trace on Printed Circuit Boards

Programming flash memories, while they reside in the target system, requires that the printed circuit board designer pay attention to the V_{PP} power supply trace. The V_{PP} pin supplies the memory cell current for programming. Use similar trace widths and layout considerations given to the V_{CC} power bus. Adequate V_{PP} supply traces and decoupling will decrease V_{PP} voltage spikes and overshoots.

V_{CC} , V_{PP} , $RP\#$ Transitions and the Command/Status Registers

Programming and erase completion are not guaranteed if V_{PP} drops below V_{PPH} . If the V_{PP} Status bit of the Status Register (SR.3) is set to "1", a Clear Status Register command MUST be issued before further program/erase attempts are allowed by the WSM. Otherwise, the Program (SR.4) or Erase (SR.5) Status bits of the Status Register will be set to "1" if error is detected. $RP\#$ transitions to V_{IL} during program and erase also abort the operations. Data is partially altered in either case, and the command sequence must be repeated after normal operation is restored. Device poweroff, or $RP\#$ transitions to V_{IL} , clear the Status Register to initial value 80H.

The Command Register latches commands as issued by system software and is not altered by V_{PP} or $CE\#$ transitions or WSM actions. Its state upon powerup, after exit from Deep-Powerdown or after V_{CC} transitions below V_{LKO} , is FFH, or Read Array Mode.

After program or erase is complete, even after V_{PP} transitions down to V_{PPL} , the Command Register must be reset to read array mode via the Read Array command if access to the memory array is desired.

Power Up/Down Protection

The 28F001BX is designed to offer protection against accidental erasure or programming during power transitions. Upon power-up, the 28F001BX is indifferent as to which power supply, V_{PP} or V_{CC} , powers up first. Power supply sequencing is not required. Internal circuitry in the 28F001BX ensures that the Command Register is reset to Read Array mode on power up.

A system designer must guard against spurious writes for V_{CC} voltages above V_{LKO} when V_{PP} is active. Since both $WE\#$ and $CE\#$ must be low for a command write, driving either to V_{IH} will inhibit writes. The Command Register architecture provides an added level of protection since alteration of memory contents only occurs after successful completion of the two-step command sequences.

Finally, the device is disabled, until $RP\#$ is brought to V_{IH} , regardless of the state of its control inputs. This provides an additional level of protection.

28F001BX Power Dissipation

When designing portable systems, designers must consider battery power consumption not only during device operation, but also for data retention during system idle time. Flash nonvolatility increases usable battery life because the 28F001BX does not consume any power to retain code or data when the system is off.

In addition, the 28F001BX's Deep-Powerdown mode ensures extremely low power dissipation even when system power is applied. For example, laptop and other PC applications, after copying BIOS to DRAM, can lower $RP\#$ to V_{IL} , producing negligible power consumption. If access to the boot code is again needed, as in case of a system $RESET\#$, the part can again be accessed, following the t_{PHAV} wakeup cycle required after $RP\#$ is first raised back to V_{IH} . The first address presented to the device while in powerdown requires time t_{PHAV} , after $RP\#$ transitions high, before outputs are valid. Further accesses follow normal timing. See AC Characteristics—Read-Only Operations and Figure 12 for more information.



ABSOLUTE MAXIMUM RATINGS*

- Operating Temperature
 - During Read0°C to 70°C(1)
 - During Erase/Program0°C to 70°C(1)
- Operating Temperature
 - During Read -40°C to +85°C(2)
 - During Erase/Program -40°C to +85°C(2)
- Temperature under Bias -10°C to 80°C(1)
- Temperature under Bias -20°C to +90°C(2)
- Storage Temperature..... -65°C to 125°C
- Voltage on Any Pin
(except A₉, RP#, OE#, V_{CC} and V_{PP})
with Respect to GND -2.0V to 7.0V(3)
- Voltage on A₉, RP#, and OE#
with Respect to GND -2.0V to 13.5V(3, 4)
- V_{PP} Program Voltage
with Respect to GND
During Erase/Program -2.0V to 14.0V(3, 4)
- V_{CC} Supply Voltage
with Respect to GND -2.0V to 7.0V(3)
- Output Short Circuit Current..... 100 mA(5)

NOTICE: This is a production data sheet. The specifications are subject to change without notice.

**WARNING: Stressing the device beyond the "Absolute Maximum Ratings" may cause permanent damage. These are stress ratings only. Operation beyond the "Operating Conditions" is not recommended and extended exposure beyond the "Operating Conditions" may affect device reliability.*

OPERATING CONDITIONS

Symbol	Parameter	Min	Max	Unit
T _A	Operating Temperature(1)	0	70	°C
T _A	Operating Temperature(2)	-40	85	°C
V _{CC}	Supply Voltage	4.50	5.50	V

NOTES:

1. Operating temperature is for commercial product defined by this specification.
2. Operating temperature is for extended temperature product defined by this specification.
3. Minimum DC voltage is -0.5V on input/output pins. During transitions, this level may undershoot to -2.0V for periods <20 ns. Maximum DC voltage on input/output pins is V_{CC} + 0.5V which, during transitions, may overshoot to V_{CC} + 2.0V for periods <20 ns.
4. Maximum DC voltage on A₉ or V_{PP} may overshoot to +14.0V for periods <20 ns.
5. Output shorted for no more than one second. No more than one output shorted at a time.

DC CHARACTERISTICS

V_{CC} = 5.0V ±10%, T_A = 0°C to +70°C

Symbol	Parameter	Notes	Min	Typ	Max	Unit	Test Conditions
I _{IL}	Input Load Current	1			± 1.0	μA	V _{CC} = V _{CC} Max V _{IN} = V _{CC} or GND
I _{LO}	Output Leakage Current	1			± 10	μA	V _{CC} = V _{CC} Max V _{OUT} = V _{CC} or GND
I _{CCS}	V _{CC} Standby Current			1.2	2.0	mA	V _{CC} = V _{CC} Max CE# = RP# = V _{IH}
				30	100	μA	V _{CC} = V _{CC} Max CE# = RP# = V _{CC} ±0.2V
I _{CCD}	V _{CC} Deep Power-Down Current	1		0.05	1.0	μA	RP# = GND ±0.2V

DC CHARACTERISTICS (Continued)

 $V_{CC} = 5.0V \pm 10\%$, $T_A = 0^\circ C$ to $+70^\circ C$

Symbol	Parameter	Notes	Min	Typ	Max	Unit	Test Conditions
I _{CCR}	V _{CC} Read Current	1		13	30	mA	V _{CC} = V _{CC} Max, CE# = V _{IL} f = 8 MHz, I _{OUT} = 0 mA
I _{CCP}	V _{CC} Programming Current	1		5	20	mA	Programming in Progress
I _{CCE}	V _{CC} Erase Current	1		6	20	mA	Erase in Progress
I _{CCES}	V _{CC} Erase Suspend Current	1, 2		5	10	mA	Erase Suspended CE# = V _{IH}
I _{PPS}	V _{PP} Standby Current	1		± 1	± 10	μA	V _{PP} ≤ V _{CC}
				90	200	μA	V _{PP} > V _{CC}
I _{PPD}	V _{PP} Deep Power-Down Current	1		0.80	1.0	μA	RP# = GND ± 0.2V
I _{PPP}	V _{PP} Programming Current	1		6	30	mA	V _{PP} = V _{PPH} Programming in Progress
I _{PPE}	V _{PP} Erase Current	1		6	30	mA	V _{PP} = V _{PPH} Erase in Progress
I _{PPES}	V _{PP} Erase Suspend Current	1		90	300	μA	V _{PP} = V _{PPH} Erase Suspended
I _{ID}	A ₉ Intelligent Identifier Current	1		90	500	μA	A ₉ = V _{ID}
V _{IL}	Input Low Voltage		-0.5		0.8	V	
V _{IH}	Input High Voltage		2.0		V _{CC} + 0.5	V	
V _{OL}	Output Low Voltage				0.45	V	V _{CC} = V _{CC} Min I _{OL} = 5.8 mA
V _{OH}	Output High Voltage		2.4			V	V _{CC} = V _{CC} Min I _{OH} = 2.5 mA
V _{ID}	A ₉ Intelligent Identifier Voltage		11.5		13.0	V	
V _{PPPL}	V _{PP} during Normal Operations	3	0.0		6.5	V	
V _{PPH}	V _{PP} during Prog/Erase Operations		11.4	12.0	12.6	V	
V _{LKO}	V _{CC} Erase/Write Lock Voltage		2.5			V	
V _{HH}	RP#, OE# Unlock Voltage		11.4		12.6	V	Boot Block Prog/Erase

NOTES:

1. All currents are in RMS unless otherwise noted. Typical values at V_{CC} = 5.0V, V_{PP} = 12.0V, T_A = 25°C. These currents are valid for all product versions (packages and speeds).
2. I_{CCES} is specified with the device deselected. If the 28F001BX is read while in Erase Suspend mode, current draw is the sum of I_{CCES} and I_{CCR}.
3. Erase/Programs are inhibited when V_{PP} = V_{PPPL} and not guaranteed in the range between V_{PPH} and V_{PPPL}.

DC CHARACTERISTICS
 $V_{CC} = 5.0V \pm 10\%$, $T_A = -40^\circ C$ to $+85^\circ C$

Symbol	Parameter	Notes	Min	Typ	Max	Unit	Test Conditions
I_{IL}	Input Load Current	1			± 1.0	μA	$V_{CC} = V_{CC} \text{ Max}$ $V_{IN} = V_{CC} \text{ or GND}$
I_{LO}	Output Leakage Current	1			± 10	μA	$V_{CC} = V_{CC} \text{ Max}$ $V_{OUT} = V_{CC} \text{ or GND}$
I_{CCS}	V_{CC} Standby Current			1.2	2.0	mA	$V_{CC} = V_{CC} \text{ Max}$ $CE\# = RP\# = V_{IH}$
				30	150	μA	$V_{CC} = V_{CC} \text{ Max}$ $CE\# = RP\# = V_{CC} \pm 0.2V$
I_{CCD}	V_{CC} Deep Power-Down Current	1		0.05	2.0	μA	$RP\# = GND \pm 0.2V$
I_{CCR}	V_{CC} Read Current	1		13	35	mA	$V_{CC} = V_{CC} \text{ Max}$, $CE\# = V_{IL}$ $f = 8 \text{ MHz}$, $I_{OUT} = 0 \text{ mA}$
I_{CCP}	V_{CC} Programming Current	1		5	20	mA	Programming in Progress
I_{CCE}	V_{CC} Erase Current	1		6	20	mA	Erase in Progress
I_{CCES}	V_{CC} Erase Suspend Current	1, 2		5	10	mA	Erase Suspended $CE\# = V_{IH}$
I_{PPS}	V_{PP} Standby Current	1		± 1	± 15	μA	$V_{PP} \leq V_{CC}$
				90	400	μA	$V_{PP} > V_{CC}$
I_{PPD}	V_{PP} Deep Power-Down Current	1		0.80	1.0	μA	$RP\# = GND \pm 0.2V$
I_{PPP}	V_{PP} Programming Current	1		6	30	μA	$V_{PP} = V_{PPH}$ Programming in Progress
I_{PPE}	V_{PP} Erase Current	1		6	30	mA	$V_{PP} = V_{PPH}$ Erase in Progress
I_{PPES}	V_{PP} Erase Suspend Current	1		90	400	μA	$V_{PP} = V_{PPH}$ Erase Suspended
I_{ID}	A_9 Intelligent Identifier Current	1		90	500	μA	$A_9 = V_{ID}$
V_{IL}	Input Low Voltage		-0.5		0.8	V	
V_{IH}	Input High Voltage		2.0		$V_{CC} + 0.5$	V	
V_{OL}	Output Low Voltage				0.45	V	$V_{CC} = V_{CC} \text{ Min}$ $I_{OL} = 5.8 \text{ mA}$
V_{OH1}	Output High Voltage (TTL)		2.4			V	$V_{CC} = V_{CC} \text{ Min}$ $I_{OH} = 2.5 \text{ mA}$
V_{OH2}	Output High Voltage (CMOS)		0.85 V_{CC}			V	$V_{CC} = V_{CC} \text{ Min}$ $I_{OH} = -2.5 \mu A$
			$V_{CC} - 0.4$			V	$V_{CC} = V_{CC} \text{ Min}$ $I_{OH} = -100 \mu A$
V_{ID}	A_9 Intelligent Identifier Voltage		11.5		13.0	V	
V_{PPL}	V_{PP} during Normal Operations	3	0.0		6.5	V	
V_{PPH}	V_{PP} during Prog/Erase Operations		11.4	12.0	12.6	V	
V_{LKO}	V_{CC} Erase/Write Lock Voltage		2.5			V	
V_{HH}	$RP\#, OE\#$ Unlock Voltage		11.4		12.6	V	Boot Block Prog/Erase

NOTES:

1. All currents are in RMS unless otherwise noted. Typical values at $V_{CC} = 5.0V$, $V_{PP} = 12.0V$, $T_A = 25^\circ C$. These currents are valid for all product versions (packages and speeds).
2. I_{CCES} is specified with the device deselected. If the 28F001BX is read while in Erase Suspend mode, current draw is the sum of I_{CCES} and I_{CCR} .
3. Erase/Programs are inhibited when $V_{PP} = V_{PPL}$ and not guaranteed in the range between V_{PPH} and V_{PPL} .

CAPACITANCE(1) $T_A = 25^\circ C$, $f = 1\text{ MHz}$

Symbol	Parameter	Max	Unit	Conditions
C_{IN}	Input Capacitance	8	pF	$V_{IN} = 0V$
C_{OUT}	Output Capacitance	12	pF	$V_{OUT} = 0V$

NOTE:

1. Sampled, not 100% tested.

AC INPUT/OUTPUT REFERENCE WAVEFORM

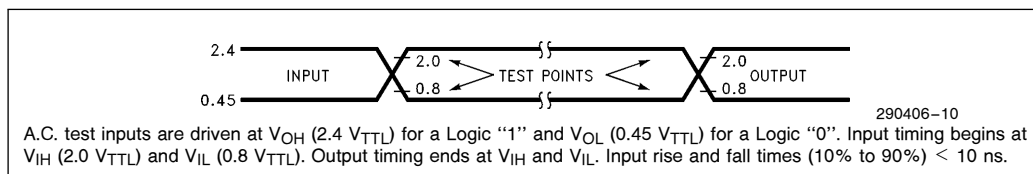

**STANDARD TEST CONFIGURATION
AC TESTING LOAD CIRCUIT**

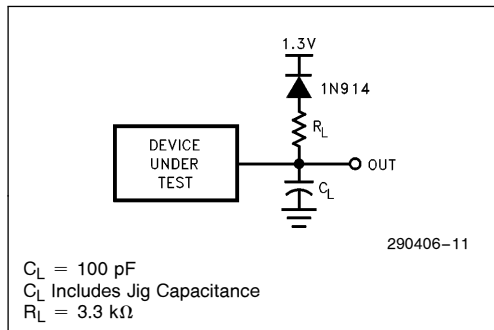

**HIGH SPEED TEST CONFIGURATION
AC TESTING LOAD CIRCUIT**

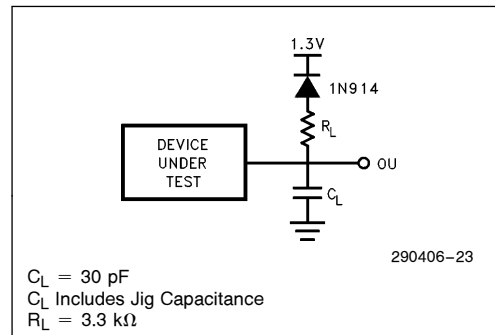

AC CHARACTERISTICS—Read-Only Operations⁽¹⁾

Symbol	Parameter	Notes	28F001BX-70				28F001BX-90		Units
			V _{CC} = 5V ± 5% 30 pF		V _{CC} = 5V ± 10% 100 pF		V _{CC} = 5V ± 10% 100 pF		
			Min	Max	Min	Max	Min	Max	
t _{AVAV}	t _{RC}	Read Cycle Time		70		75		90	ns
t _{AVQV}	t _{ACC}	Address to Output Delay			70		75		90
t _{ELQV}	t _{CE}	CE # to Output Delay	2		70		75		90
t _{PHQV}	t _{PWH}	RP # to Output Delay			600		600		600
t _{GLQV}	t _{OE}	OE # to Output Delay	2		27		30		35
t _{ELQX}	t _{LZ}	CE # to Output in Low Z	3	0		0		0	ns
t _{EHQZ}	t _{HZ}	CE # to Output in High Z	3		55		55		35
t _{GLQX}	t _{OLZ}	OE # to Output in Low Z	3	0		0		0	ns
t _{GHQZ}	t _{DF}	OE # to Output in High Z	3		30		30		30
	t _{OH}	Output Hold from Address CE #, or OE # Change, Whichever Occurs First	3	0		0		0	ns

NOTES:

1. See AC Input/Output Reference Waveform for timing measurements.
2. OE # may be delayed up to t_{CE}-t_{OE} after the falling edge of CE # without impact on t_{CE}.
3. Sampled, but not 100% tested.
4. See High Speed Test Configuration.
5. See Standard Test Configuration.

AC CHARACTERISTICS—Read-Only Operations⁽¹⁾

Versions ⁽²⁾		$V_{CC} \pm 10\%$		E28F001BX-120 N28F001BX-120 P28F001BX-120		E28F001BX-150 TE28F001BX-150 N28F001BX-150 TN28F001BX-150 P28F001BX-150		Unit
Symbol	Parameter	Notes	Min	Max	Min	Max		
t_{AVAV}	t_{RC}	Read Cycle Time		120		150		ns
t_{AVQV}	t_{ACC}	Address to Output Delay			120		150	ns
t_{ELQV}	t_{CE}	CE # to Output Delay	3		120		150	ns
t_{PHQV}	t_{PWH}	RP# High to Output Delay			600		600	ns
t_{GLQV}	t_{OE}	OE # to Output Delay	3		50		55	ns
t_{ELQX}	t_{LZ}	CE # to Output Low Z	4	0		0		ns
t_{EHQZ}	t_{HZ}	CE # High to Output High Z	4		55		55	ns
t_{GLQX}	t_{OLZ}	OE # to Output Low Z	4	0		0		ns
t_{GHQZ}	t_{DF}	OE # High to Output High Z	4		30		30	ns
	t_{OH}	Output Hold from Addresses, CE # or OE # Change, Whichever is First	4	0		0		ns

NOTES:

1. See AC Input/Output Reference Waveform for timing measurements.
2. Model Number Prefixes: E = TSOP (Standard Pinout), N = PLCC, P = PDIP, T = Extended Temperature. Refer to standard test configuration.
3. OE # may be delayed up to $t_{CE}-t_{OE}$ after the falling edge of CE # without impact on t_{CE} .
4. Sampled, not 100% tested.

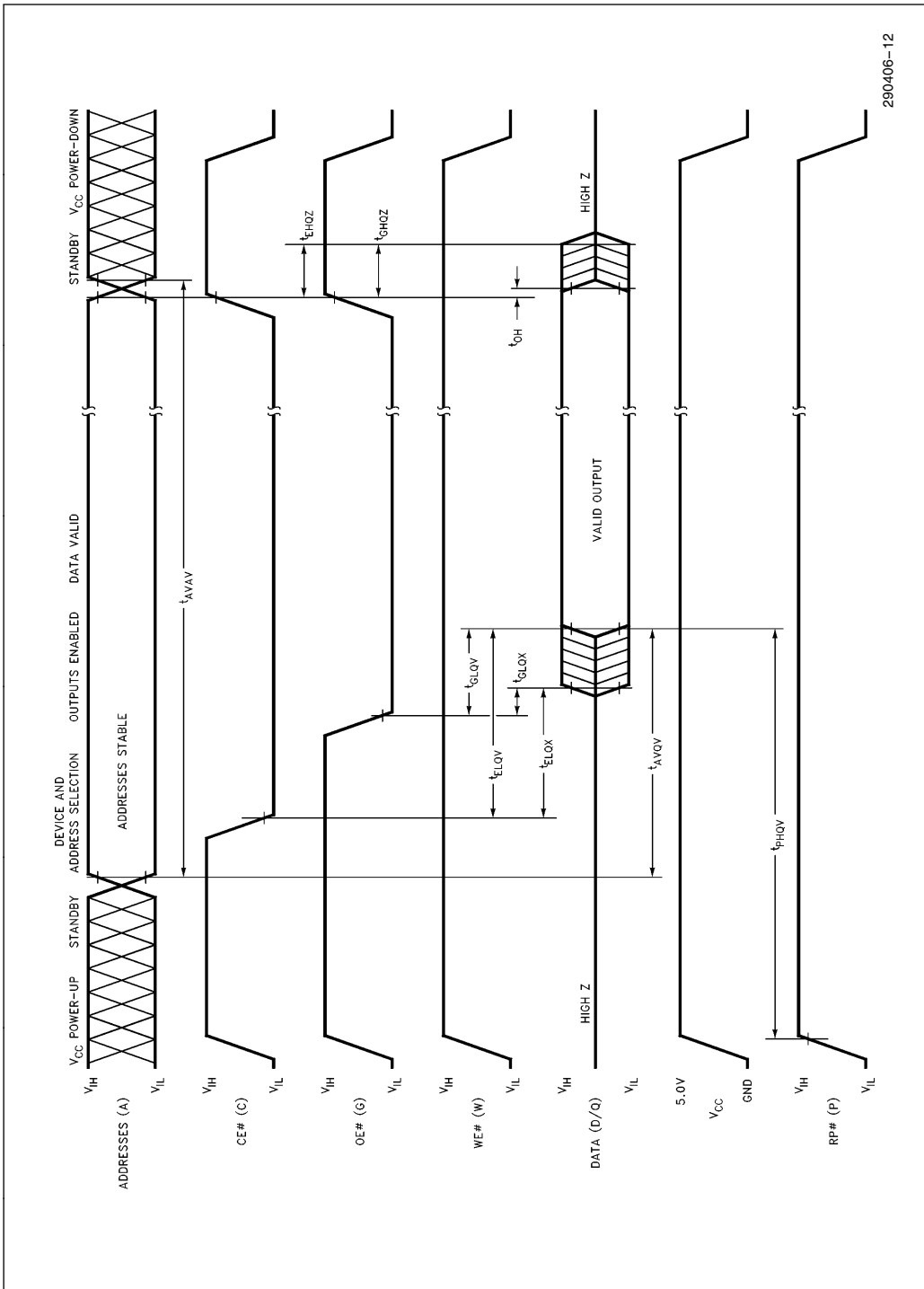

290406-12

Figure 12. AC Waveform for Read Operations

AC CHARACTERISTICS—Write/Erase/Program Operations(1, 9)

Symbol	Parameter	Notes	28F001BX-70				28F001BX-90		Units
			V _{CC} = 5V ± 5% ⁽¹⁰⁾ 30 pF		V _{CC} = 5V ± 10% ⁽¹¹⁾ 100 pF		V _{CC} = 5V ± 10% ⁽¹¹⁾ 100 pF		
			Min	Max	Min	Max	Min	Max	
t _{AVAV}	t _{WC}	Write Cycle Time		70		75		90	ns
t _{PHWL}	t _{PS}	RP # High Recovery to WE # Going Low	2	480		480		480	ns
t _{ELWL}	t _{CS}	CE # Setup to WE # Going Low		10		10		10	ns
t _{WLWH}	t _{WP}	WE # Pulse Width		35		40		40	ns
t _{PHHWH}	t _{PHS}	RP # V _{HH} Setup to WE # Going High	2	100		100		100	ns
t _{VPWH}	t _{VPS}	V _{PP} Setup to WE # Going High	2	100		100		100	ns
t _{AVWH}	t _{AS}	Address Setup to WE # Going High	3	35		40		40	ns
t _{DVWH}	t _{DS}	Data Setup to WE # Going High	4	35		40		40	ns
t _{WHDX}	t _{DH}	Data Hold from WE # High		10		10		10	ns
t _{WHAX}	t _{AH}	Address Hold from WE # High		10		10		10	ns
t _{WHEH}	t _{CH}	CE # Hold from WE # High		10		10		10	ns
t _{WHWL}	t _{WPH}	WE # Pulse Width High		35		35		35	ns
t _{WHQV1}		Duration of Programming Operation	5, 6, 7	15		15		15	μs
t _{WHQV2}		Duration of Erase Operation (Boot)	5, 6, 7	1.3		1.3		1.3	sec
t _{WHQV3}		Duration of Erase Operation (Parameter)	5, 6, 7	1.3		1.3		1.3	sec
t _{WHQV4}		Duration of Erase Operation (Main)	5, 6, 7	3.0		3.0		3.0	sec
t _{WHGL}		Write Recovery before Read		0		0		0	μs
t _{QVVL}	t _{VPH}	V _{PP} Hold from Valid SRD	2, 6	0		0		0	ns
t _{QVPH}	t _{PHH}	RP # V _{HH} Hold from Valid SRD	2, 7	0		0		0	ns
t _{PHBR}		Boot-Block Relock Delay	2		100		100		100 ns

NOTES:

- Read timing characteristics during erase and program operations are the same as during read-only operations. Refer to AC Characteristics for Read-Only Operations.
- Sampled, not 100% tested.
- Refer to Table 3 for valid A_{IN} for byte programming or block erasure.
- Refer to Table 3 for valid D_{IN} for byte programming or block erasure.
- The on-chip Write State Machine incorporates all program and erase system functions and overhead of standard Intel Flash Memory, including byte program and verify (programming) and block precondition, precondition verify, erase and erase verify (erasing).
- Program and erase durations are measured to completion (SR.7 = 1). V_{PP} should be held at V_{PPH} until determination of program/erase success (SR.3/4/5 = 0).
- For boot block programming and erasure, RP # should be held at V_{HH} until determination of program/erase success (SR.3/4/5 = 0).
- Alternate boot block access method.
- Erase/Program Cycles on extended temperature products is 10,000 cycles.
- See high speed test configuration.
- See standard test configuration.

AC CHARACTERISTICS—Write/Erase/Program Operations(1, 9)

Versions		$V_{CC} \pm 10\%$ (10)		28F001BX-120		28F001BX-150		Unit
Symbol	Parameter	Notes	Min	Max	Min	Max		
t_{AVAV}	t_{WC}	Write Cycle Time		120		150		ns
t_{PHWL}	t_{PS}	RP# High Recovery to WE# Going Low	2	480		480		ns
t_{ELWL}	t_{CS}	CE# Setup to WE# Going Low		10		10		ns
t_{WLWH}	t_{WP}	WE# Pulse Width		50		50		ns
t_{PHHWH}	t_{PHS}	RP# V_{HH} Setup to WE# Going High	2	100		100		ns
t_{VPWH}	t_{VPS}	V_{PP} Setup to WE# Going High	2	100		100		ns
t_{AVWH}	t_{AS}	Address Setup to WE# Going High	3	50		50		ns
t_{DVWH}	t_{DS}	Data Setup to WE# Going High	4	50		50		ns
t_{WHDX}	t_{DH}	Data Hold from WE# High		10		10		ns
t_{WHAX}	t_{AH}	Address Hold from WE# High		10		10		ns
t_{WHEH}	t_{CH}	CE# Hold from WE# High		10		10		ns
t_{WHWL}	t_{WPH}	WE# Pulse Width High		50		50		ns
t_{WHQV1}		Duration of Programming Operation	5, 6, 7	15		15		μ s
t_{WHQV2}		Duration of Erase Operation (Boot)	5, 6, 7	1.3		1.3		sec
t_{WHQV3}		Duration of Erase Operation (Parameter)	5, 6, 7	1.3		1.3		sec
t_{WHQV4}		Duration of Erase Operation (Main)	5, 6, 7	3.0		3.0		sec
t_{WHGL}		Write Recovery before Read		0		0		μ s
t_{QVVL}	t_{VPH}	V_{PP} Hold from Valid SRD	2, 6	0		0		ns
t_{QVPH}	t_{PHH}	RP# V_{HH} Hold from Valid SRD	2, 7	0		0		ns
t_{PHBR}		Boot-Block Relock Delay	2		100		100	ns

PROM Programmer Specifications

Versions		$V_{CC} \pm 10\%$		28F001BX-120		28F001BX-150		Unit
Symbol	Parameter	Notes	Min	Max	Min	Max		
t_{GHHWL}	OE# V_{HH} Setup to WE# Going Low	2, 8	480		480		ns	
t_{WHGH}	OE# V_{HH} Hold from WE# High	2, 8	480		480		ns	

NOTES:

- Read timing characteristics during erase and program operations are the same as during read-only operations. Refer to AC Characteristics for Read-Only Operations.
- Sampled, not 100% tested.
- Refer to Table 3 for valid A_{IN} for byte programming or block erasure.
- Refer to Table 3 for valid D_{IN} for byte programming or block erasure.
- The on-chip Write State Machine incorporates all program and erase system functions and overhead of standard Intel Flash Memory, including byte program and verify (programming) and block precondition, precondition verify, erase and erase verify (erasing).
- Program and erase durations are measured to completion (SR.7 = 1). V_{PP} should be held at V_{PPH} until determination of program/erase success (SR.3/4/5 = 0).
- For boot block programming and erasure, RP# should be held at V_{HH} until determination of program/erase success (SR.3/4/5 = 0).
- Alternate boot block access method.
- Erase/Program Cycles on extended temperature products is 10,000 cycles.
- See standard test configuration.

ERASE AND PROGRAMMING PERFORMANCE

Parameter	Notes	28F001BX-120			28F001BX-150			Unit
		Min	Typ ⁽¹⁾	Max	Min	Typ ⁽¹⁾	Max	
Boot Block Erase Time	2		2.10	14.9		2.10	14.9	Sec
Boot Block Program Time	2		0.15	0.52		0.15	0.52	Sec
Parameter Block Erase Time	2		2.10	14.6		2.10	14.6	Sec
Parameter Block Program Time	2		0.07	0.26		0.07	0.26	Sec
Main Block Erase Time	2		3.80	20.9		3.80	20.9	Sec
Main Block Program Time	2		2.10	7.34		2.10	7.34	Sec
Chip Erase Time	2		10.10	65		10.10	65	Sec
Chip Program Time	2		2.39	8.38		2.39	8.38	Sec

NOTES:

1. 25°C, 12.0 V_{pp}.
2. Excludes System-Level Overhead.



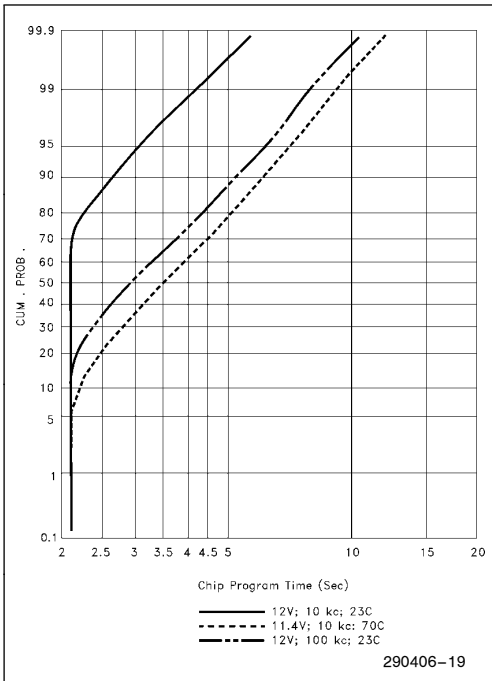

Figure 13. 28F001BX Typical Programming Capability

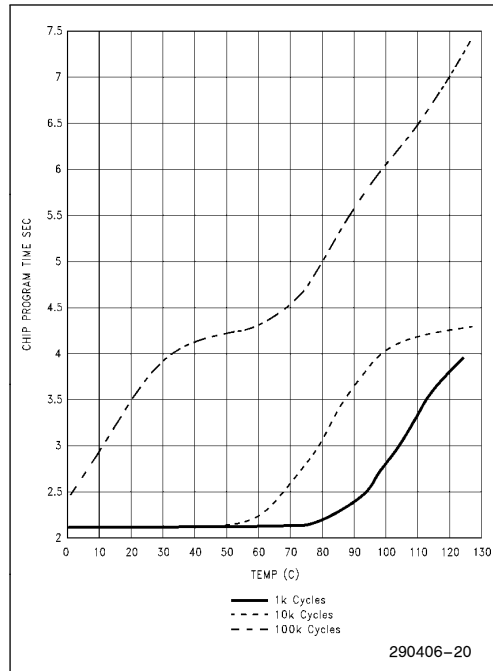

Figure 14. 28F001BX Typical Programming Time at 12V

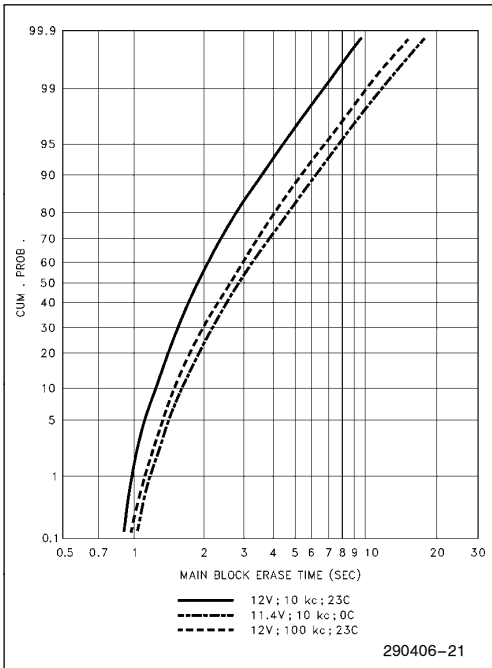

Figure 15. 28F001BX Typical Erase Capability

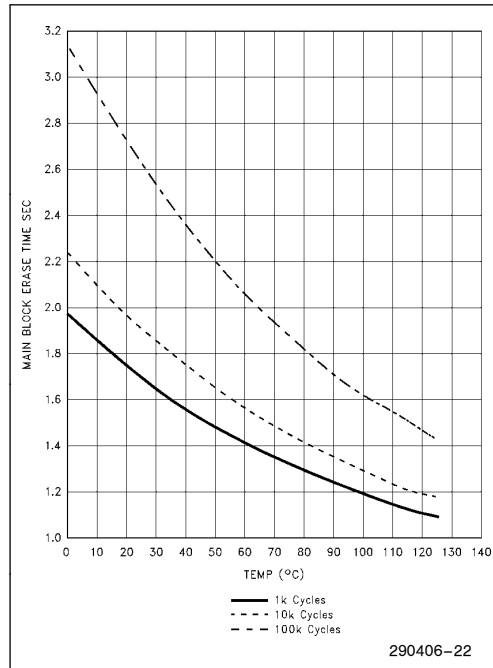
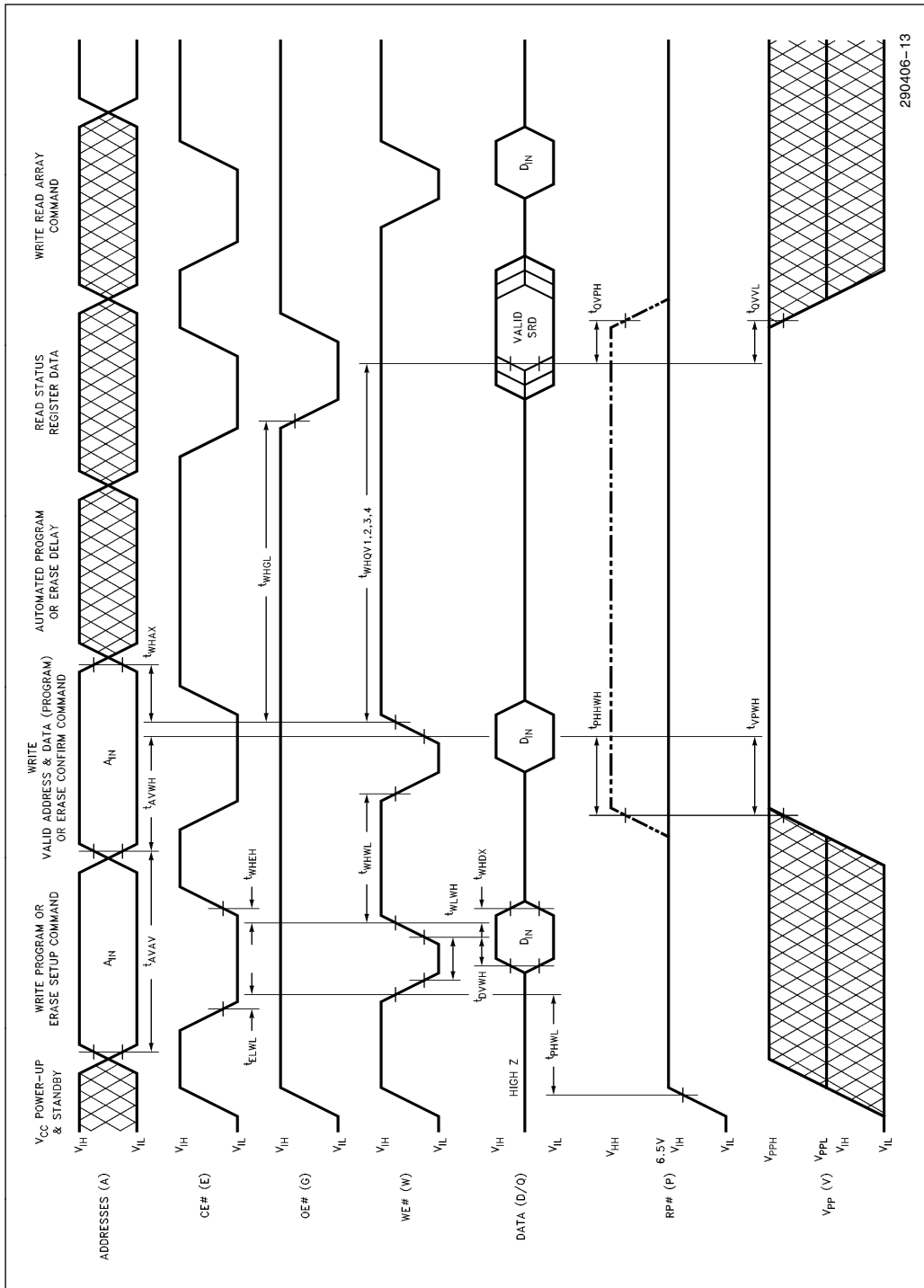

Figure 16. 28F001BX Typical Erase Time at 12V



290406-13

Figure 17. AC Waveform for Write Operations

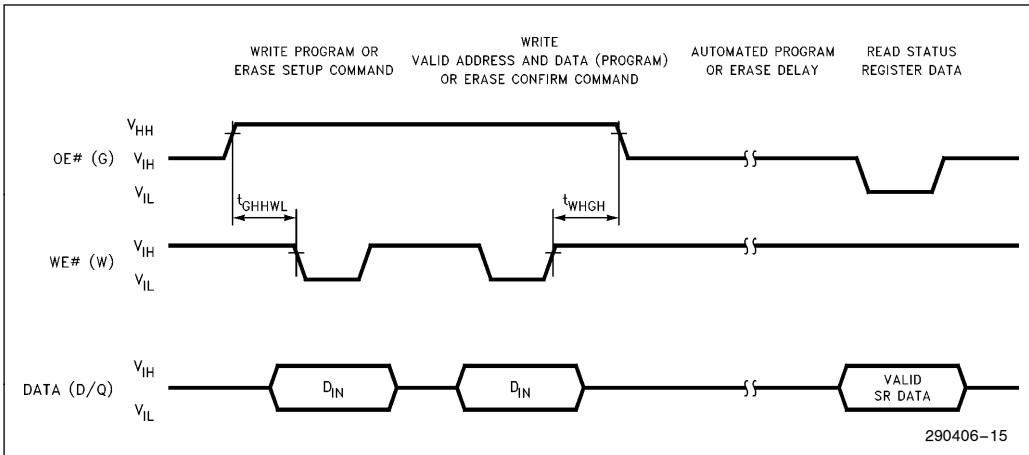

Figure 18. Alternate Boot Block Access Method Using OE #



AC CHARACTERISTICS FOR CE #-CONTROLLED WRITES(1)

Symbol		Parameter	Notes	28F001BX-70				28F001BX-90		Units
				V _{CC} = 5V ± 5% ⁽⁸⁾ 30 pF		V _{CC} = 5V ± 10% ⁽⁹⁾ 100 pF		V _{CC} = 5V ± 10% ⁽⁹⁾ 100 pF		
				Min	Max	Min	Max	Min	Max	
t _{AVAV}	t _{WC}	Write Cycle Time		70		75		90		ns
t _{PHL}	t _{PS}	RP # High Recovery to CE # Going Low	2	480		480		480		ns
t _{WLEL}	t _{WS}	WE # Setup to CE # Going Low		0		0		0		ns
t _{ELEH}	t _{CP}	CE # Pulse Width		50		55		55		ns
t _{PHHEH}	t _{PHS}	RP # V _{HH} Setup to CE # Going High	2	100		100		100		ns
t _{VPEH}	t _{VPS}	V _{PP} Setup to CE # Going High	2	100		100		100		ns
t _{AVEH}	t _{AS}	Address Setup to CE # Going High	3	35		40		40		ns
t _{DVEH}	t _{DS}	Data Setup to CE # Going High	4	35		40		40		ns
t _{EHDX}	t _{DH}	Data Hold from CE # High		10		10		10		ns
t _{EHAX}	t _{AH}	Address Hold from CE # High		10		10		10		ns
t _{EHWH}	t _{WH}	WE # Hold from CE # High		0		0		0		ns
t _{EHEL}	t _{EPH}	CE # Pulse Width High		20		20		20		ns
t _{EHQV1}		Duration of Programming Operation	5, 6	15		15		15		μs
t _{EHQV2}		Duration of Erase Operation (Boot)	5, 6	1.3		1.3		1.3		sec
t _{EHQV3}		Duration of Erase Operation (Parameter)	5, 6	1.3		1.3		1.3		sec
t _{EHQV4}		Duration of Erase Operation (Main)	5, 6	3.0		3.0		3.0		sec
t _{EHGL}		Write Recovery before Read		0		0		0		μs
t _{QVVL}	t _{VPH}	V _{PP} Hold from Valid SRD	2, 5	0		0		0		ns
t _{QVPH}	t _{PHH}	RP # V _{HH} Hold from Valid SRD	2, 6	0		0		0		ns
t _{PHBR}		Boot-Block Relock Delay	2		100		100		100	ns

NOTES:

1. Chip-Enable Controlled Writes: Write operations are driven by the valid combination of CE # and WE #. In systems where CE # defines the write pulse width (within a longer WE # timing waveform), all set-up, hold and inactive WE # times should be measured relative to the CE # waveform.
2. Sampled, not 100% tested.
3. Refer to Table 3 for valid A_{IN} for byte programming or block erasure.
4. Refer to Table 3 for valid D_{IN} for byte programming or block erasure.
5. Program and erase durations are measured to completion (SR.7 = 1). V_{PP} should be held at V_{PPH} until determination of program/erase success (SR.3/4/5 = 0).
6. For boot block programming and erasure, RP # should be held at V_{HH} until determination of program/erase success (SR.3/4/5 = 0).
7. Alternate boot block access method.
8. See high speed test configuration.
9. See standard text configuration.

AC CHARACTERISTICS FOR CE #-CONTROLLED WRITES(1)

Versions		$V_{CC} \pm 10\%$		28F001BX-120		28F001BX-150		Unit
Symbol	Parameter	Notes	Min	Max	Min	Max		
t_{AVAV}	t_{WC}	Write Cycle Time		120		150		ns
t_{PHEL}	t_{PS}	RP # High Recovery to CE # Going Low	2	480		480		ns
t_{WLEL}	t_{WS}	WE # Setup to CE # Going Low		0		0		ns
t_{ELEH}	t_{CP}	CE # Pulse Width		70		70		ns
t_{PHHEH}	t_{PHS}	RP # V_{HH} Setup to CE # Going High	2	100		100		ns
t_{VPEH}	t_{VPS}	V_{PP} Setup to CE # Going High	2	100		100		ns
t_{AVEH}	t_{AS}	Address Setup to CE # Going High	3	50		50		ns
t_{DVEH}	t_{DS}	Data Setup to CE # Going High	4	50		50		ns
t_{EHDX}	t_{DH}	Data Hold from CE # High		10		10		ns
t_{EHAX}	t_{AH}	Address Hold from CE # High		15		15		ns
t_{EHWH}	t_{WH}	WE # Hold from CE # High		0		0		ns
t_{EHEL}	t_{EPH}	CE # Pulse Width High		25		25		ns
t_{EHQV1}		Duration of Programming Operation	5, 6	15		15		μ s
t_{EHQV2}		Duration of Erase Operation (Boot)	5, 6	1.3		1.3		sec
t_{EHQV3}		Duration of Erase Operation (Parameter)	5, 6	1.3		1.3		sec
t_{EHQV4}		Duration of Erase Operation (Main)	5, 6	3.0		3.0		sec
t_{EHGL}		Write Recovery before Read		0		0		μ s
t_{QVVL}	t_{VPH}	V_{PP} Hold from Valid SRD	2, 5	0		0		ns
t_{QVPH}	t_{PHH}	RP # V_{HH} Hold from Valid SRD	2, 6	0		0		ns
t_{PHBR}		Boot-Block Relock Delay	2		100		100	ns

PROM Programmer Specifications

Versions		$V_{CC} \pm 10\%$		28F001BX-120		28F001BX-150		Unit
Symbol	Parameter	Notes	Min	Max	Min	Max		
t_{GHHEL}	OE # V_{HH} Setup to CE # Going Low	2, 7	480		480		ns	
t_{EHGH}	OE # V_{HH} Hold from CE # High	2, 7	480		480		ns	

NOTES:

- Chip-Enable Controlled Writes: Write operations are driven by the valid combination of CE # and WE #. In systems where CE # defines the write pulse width (within a longer WE # timing waveform), all set-up, hold and inactive WE # times should be measured relative to the CE # waveform.
- Sampled, not 100% tested.
- Refer to Table 3 for valid A_{IN} for byte programming or block erasure.
- Refer to Table 3 for valid D_{IN} for byte programming or block erasure.
- Program and erase durations are measured to completion (SR.7 = 1). V_{PP} should be held at V_{PPH} until determination of program/erase success (SR.3/4/5 = 0).
- For boot block programming and erasure, RP # should be held at V_{HH} until determination of program/erase success (SR.3/4/5 = 0).
- Alternate boot block access method.



ORDERING INFORMATION

T	P	2	8	F	0	0	1	B	X	-	T	1	2	0
---	---	---	---	---	---	---	---	---	---	---	---	---	---	---

PACKAGE

- E STANDARD 32 LEAD TSOP
- N 32 LEAD PLCC
- P 32-PIN PLASTIC DIP

TEMPERATURE RANGE

- T = EXTENDED (-40°C to +85°C)
- BLANK = COMMERCIAL (0°C to +70°C)

ACCESS SPEED (ns)

- 70 ns
- 90 ns
- 120 ns
- 150 ns

T TOP BOOT DEVICE
B BOTTOM BOOT DEVICE

290406-18

VALID COMBINATIONS:

	32-Lead TSOP	32-Lead PLCC	32-Pin PDIP
Commercial	E28F001BX-T70	N28F001BX-T70	P28F001BX-T70
	E28F001BX-T90	N28F001BX-T90	P28F001BX-T90
	E28F001BX-T120	N28F001BX-T120	P28F001BX-T120
	E28F001BX-T150	N28F001BX-T150	P28F001BX-T150
	E28F001BX-B70	N28F001BX-B70	P28F001BX-B70
	E28F001BX-B90	N28F001BX-B90	P28F001BX-B90
	E28F001BX-B120	N28F001BX-B120	P28F001BX-B120
	E28F001BX-B150	N28F001BX-B150	P28F001BX-B150
Extended	TE28F001BX-T90	TN28F001BX-T90	TP28F001BX-T90
	TE28F001BX-T150	TN28F001BX-T150	TP28F001BX-B90
	TE28F001BX-B90	TN28F001BX-B90	
	TE28F001BX-B150	TN28F001BX-B150	

ADDITIONAL INFORMATION

References

Order Number	Document
292046	AP-316 "Using Flash Memory for In-System Reprogrammable Nonvolatile Storage"
292077	AP-341 "Designing an Updateable BIOS Using Flash Memory"
292161	AP-608 "Implementing a Plug and Play BIOS Using Intel's Boot Block Flash Memory"
292178	AP-623 "Multi-Site Layout Planning Using Intel's Boot Block Flash Memory"
294005	ER-20 "ETOX II Flash Memory Technology"

Revision History

Number	Description
-004	<p>Removed Preliminary classification.</p> <p>Latched address A₁₆ in Figure 5.</p> <p>Updated Boot Block Program and Erase section: "If boot block program or erase is attempted while RP# is at V_{IH}, either the Program Status or Erase Status bit will be set to "1", reflective of the operation being attempted and indicating boot block lock."</p> <p>Updated Figure 11, 28F001BX Erase Suspend/Resume Flowchart</p> <p>Added DC Characteristics typical current values</p> <p>Combined V_{PP} Standby current and V_{PP} Read current into one V_{PP} Standby current spec with two test conditions (DC Characteristics table)</p> <p>Added maximum program/erase times to Erase and Programming Performance table.</p> <p>Added Figures 13–16</p> <p>Added Extended Temperature proliferations</p>
-005	<p>PWD changed to RP# for JEDEC standardization compatibility</p> <p>Revised symbols, i.e.; \overline{CE}, \overline{OE}, etc. to CE#, OE#, etc.</p>
-006	<p>Added specifications for -90 and -70 product versions.</p> <p>Added V_{OH} CMOS Specification.</p>
-007	<p>Added reference to 28F001BN.</p>



This datasheet has been downloaded from:

www.DatasheetCatalog.com

Datasheets for electronic components.



LittleDiode supplies new, hard to find or obsolete electronic components and semiconductors all over the world.

With over two million different components listed you are sure to find the part you need.

Feel free to visit us today at our online store:

LittleDiode.com

Looking forward to providing you with the best possible service.