

March. 2003

San 16 Banwol-Ri
 Taean-Eup Hwasung- City
 Kyungki Do, Korea
 Tel.) 82 - 31 - 208 - 6463
 Fax.) 82 - 31 -208 - 6799

512Mb/256Mb 1.8V NAND Flash Errata

Description : Some of AC characteristics are not meeting the specification.

> **AC characteristics :** Refer to Table

Affected Products : K9F1208Q0A-XXB0, K9F1216Q0A-XXB0
 K9F5608Q0C-XXB0, K9F5616Q0C-XXB0
 K9K1208Q0C-XXB0, K9K1216Q0C-XXB0

Improvement schedule : The components without this restriction will
 be available from work week 23 or after.

Workaround : Relax the relevant timing parameters according to the table.

Table

UNIT : ns

Parameters	tWC	tWH	tWP	tRC	tREH	tRP	tREA	tCEA
Specification	45	15	25	50	15	25	30	45
Relaxed Condition	80	20	60	80	20	60	60	75

Sincerely,

chwoosun@sec.samsung.com



Product Planning & Application Eng.
 Memory Division
 Samsung Electronics Co.

Document Title

32M x 8 Bit , 16M x 16 Bit NAND Flash Memory

Revision History

<u>Revision No.</u>	<u>History</u>	<u>Draft Date</u>	<u>Remark</u>																											
0.0	Initial issue.	Apr. 25th 2002	Advance																											
1.0	1.Pin assignment of TBGA dummy ball is changed. (before) DNU --> (after) N.C 2. Add the Rp vs tr ,tf & Rp vs ibusy graph for 1.8V device (Page 36) 3. Add the data protection Vcc guidance for 1.8V device - below about 1.1V. (Page 37) 4. Add the specification of Block Lock scheme.(Page 32~35) 5. Pin assignment of TBGA A3 ball is changed. (before) N.C --> (after) Vss 6. Pin assignment of WSOP #38 pin is changed. (before) LOCKPRE --> (after) N.C	Dec.14th 2002	Preliminary																											
2.0	1. The Maximum operating current is changed. Program : Icc2 20mA-->25mA Erase : Icc3 20mA-->25mA	Jan. 17th 2003	Preliminary																											
2.1	The min. Vcc value 1.8V devices is changed. K9F56XXQ0C : Vcc 1.65V~1.95V --> 1.70V~1.95V	Mar. 5th 2003	Preliminary																											
2.2	Pb-free Package is added. K9F5608U0C-FCB0,FIB0 K9F5608Q0C-HCB0,HIB0 K9F5616U0C-HCB0,HIB0 K9F5616U0C-PCB0,PIB0 K9F5616Q0C-HCB0,HIB0 K9F5608U0C-HCB0,HIB0 K9F5608U0C-PCB0,PIB0	Mar. 13rd 2003																												
2.3	Errata is added.(Front Page)-K9F56XXQ0C <table border="1"> <tr> <td></td> <td>tWC</td> <td>tWH</td> <td>tWP</td> <td>tRC</td> <td>tREH</td> <td>tRP</td> <td>tREA</td> <td>tCEA</td> </tr> <tr> <td>Specification</td> <td>45</td> <td>15</td> <td>25</td> <td>50</td> <td>15</td> <td>25</td> <td>30</td> <td>45</td> </tr> <tr> <td>Relaxed value</td> <td>60</td> <td>20</td> <td>40</td> <td>60</td> <td>20</td> <td>40</td> <td>40</td> <td>55</td> </tr> </table>		tWC	tWH	tWP	tRC	tREH	tRP	tREA	tCEA	Specification	45	15	25	50	15	25	30	45	Relaxed value	60	20	40	60	20	40	40	55	Mar. 26th 2003	
	tWC	tWH	tWP	tRC	tREH	tRP	tREA	tCEA																						
Specification	45	15	25	50	15	25	30	45																						
Relaxed value	60	20	40	60	20	40	40	55																						
2.4	New definition of the number of invalid blocks is added. (Minimum 1004 valid blocks are guaranteed for each contiguous 128Mb memory space.)	Apr. 4th 2003																												

Note : For more detailed features and specifications including FAQ, please refer to Samsung's Flash web site.
<http://www.intl.samsungsemi.com/Memory/Flash/datasheets.html>

The attached datasheets are prepared and approved by SAMSUNG Electronics. SAMSUNG Electronics CO., LTD. reserve the right to change the specifications. SAMSUNG Electronics will evaluate and reply to your requests and questions about device. If you have any questions, please contact the SAMSUNG branch office near you.

32M x 8 Bit / 16M x 16 Bit NAND Flash Memory

PRODUCT LIST

Part Number	Vcc Range	Organization	PKG Type
K9F5608Q0C-D,H	1.70 ~ 1.95V	X8	TBGA
K9F5616Q0C-D,H		X16	
K9F5608U0C-Y,P	2.7 ~ 3.6V	X8	TSOP1
K9F5608U0C-D,H			TBGA
K9F5608U0C-V,F			WSOP1
K9F5616U0C-Y,P		X16	TSOP1
K9F5616U0C-D,H			TBGA

FEATURES

- Voltage Supply
 - 1.8V device(K9F56XXQ0C) : 1.70~1.95V
 - 3.3V device(K9F56XXU0C) : 2.7 ~ 3.6 V
 - Organization
 - Memory Cell Array
 - X8 device(K9F5608X0C) : (32M + 1024K)bit x 8 bit
 - X16 device(K9F5616X0C) : (16M + 512K)bit x 16bit
 - Data Register
 - X8 device(K9F5608X0C) : (512 + 16)bit x 8bit
 - X16 device(K9F5616X0C) : (256 + 8)bit x16bit
 - Automatic Program and Erase
 - Page Program
 - X8 device(K9F5608X0C) : (512 + 16)Byte
 - X16 device(K9F5616X0C) : (256 + 8)Word
 - Block Erase :
 - X8 device(K9F5608X0C) : (16K + 512)Byte
 - X16 device(K9F5616X0C) : (8K + 256)Word
 - Page Read Operation
 - Page Size
 - X8 device(K9F5608X0C) : (512 + 16)Byte
 - X16 device(K9F5616X0C) : (256 + 8)Word
 - Random Access : 10µs(Max.)
 - Serial Page Access : 50ns(Min.)
 - Fast Write Cycle Time
 - Program time : 200µs(Typ.)
 - Block Erase Time : 2ms(Typ.)
 - Command/Address/Data Multiplexed I/O Port
 - Hardware Data Protection
 - Program/Erase Lockout During Power Transitions
 - Reliable CMOS Floating-Gate Technology
 - Endurance : 100K Program/Erase Cycles
 - Data Retention : 10 Years
 - Command Register Operation
 - Intelligent Copy-Back
 - Unique ID for Copyright Protection
 - Power-On Auto-Read Operation
 - Safe Lock Mechanism
 - Package
 - K9F56XXU0C-YCB0/YIB0
 - 48 - Pin TSOP I (12 x 20 / 0.5 mm pitch)
 - K9F56XXQ0C-DCB0/DIB0
 - 63- Ball TBGA (9 x 11 /0.8mm pitch , Width 1.0 mm)
 - K9F5608U0C-VCB0/VIB0
 - 48 - Pin WSOP I (12X17X0.7mm)
 - K9F56XXU0C-PCB0/PIB0
 - 48 - Pin TSOP I (12 x 20 / 0.5 mm pitch)- Pb-free Package
 - K9F56XXQ0C-HCB0/HIB0
 - 63- Ball TBGA (9 x 11 /0.8mm pitch , Width 1.0 mm)
 - Pb-free Package
 - K9F5608U0C-FCB0/FIB0
 - 48 - Pin WSOP I (12X17X0.7mm)- Pb-free Package
- * K9F5608U0C-V,F(WSOP1) is the same device as K9F5608U0C-Y,P(TSOP1) except package type.

GENERAL DESCRIPTION

Offered in 32Mx8bit or 16Mx16bit, the K9F56XXQ0C is 256M bit with spare 8M bit capacity. The device is offered in 1.8V or 3.3V Vcc. Its NAND cell provides the most cost-effective solution for the solid state mass storage market. A program operation can be performed in typical 200µs on a 528-byte(X8 device) or 264-word(X16 device) page and an erase operation can be performed in typical 2ms on a 16K-byte(X8 device) or 8K-word(X16 device) block. Data in the page can be read out at 50ns cycle time per word. The I/O pins serve as the ports for address and data input/output as well as command input. The on-chip write control automates all program and erase functions including pulse repetition, where required, and internal verification and margining of data. Even the write-intensive systems can take advantage of the K9F56XXQ0C's extended reliability of 100K program/erase cycles by providing ECC(Error Correcting Code) with real time mapping-out algorithm.

The K9F56XXQ0C is an optimum solution for large nonvolatile storage applications such as solid state file storage and other portable applications requiring non-volatility.

K9F5608U0C-VCB0,VIB0,FCB0,FIB0
 K9F5608Q0C-DCB0,DIB0,HCB0,HIB0
 K9F5608U0C-YCB0,YIB0,PCB0,PIB0
 K9F5608U0C-DCB0,DIB0,HCB0,HIB0

K9F5616Q0C-DCB0,DIB0,HCB0,HIB0
 K9F5616U0C-YCB0,YIB0,PCB0,PIB0
 K9F5616U0C-DCB0,DIB0,HCB0,HIB0

FLASH MEMORY

PIN CONFIGURATION (TSOP1)

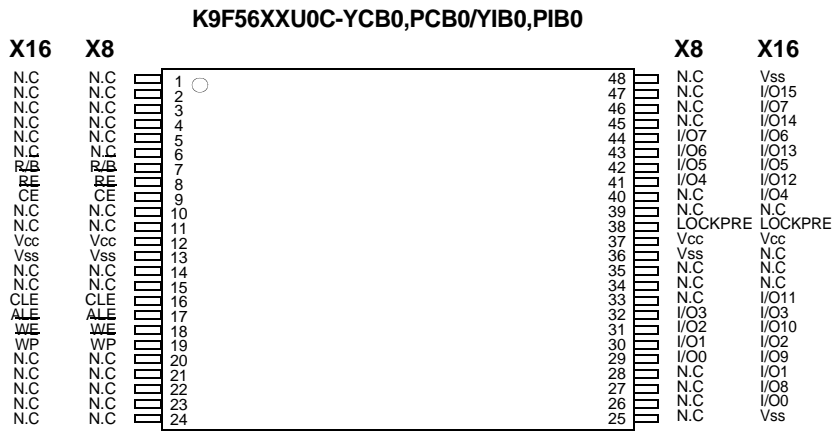

PACKAGE DIMENSIONS

48-PIN LEAD/LEAD FREE PLASTIC THIN SMALL OUT-LINE PACKAGE TYPE(I)

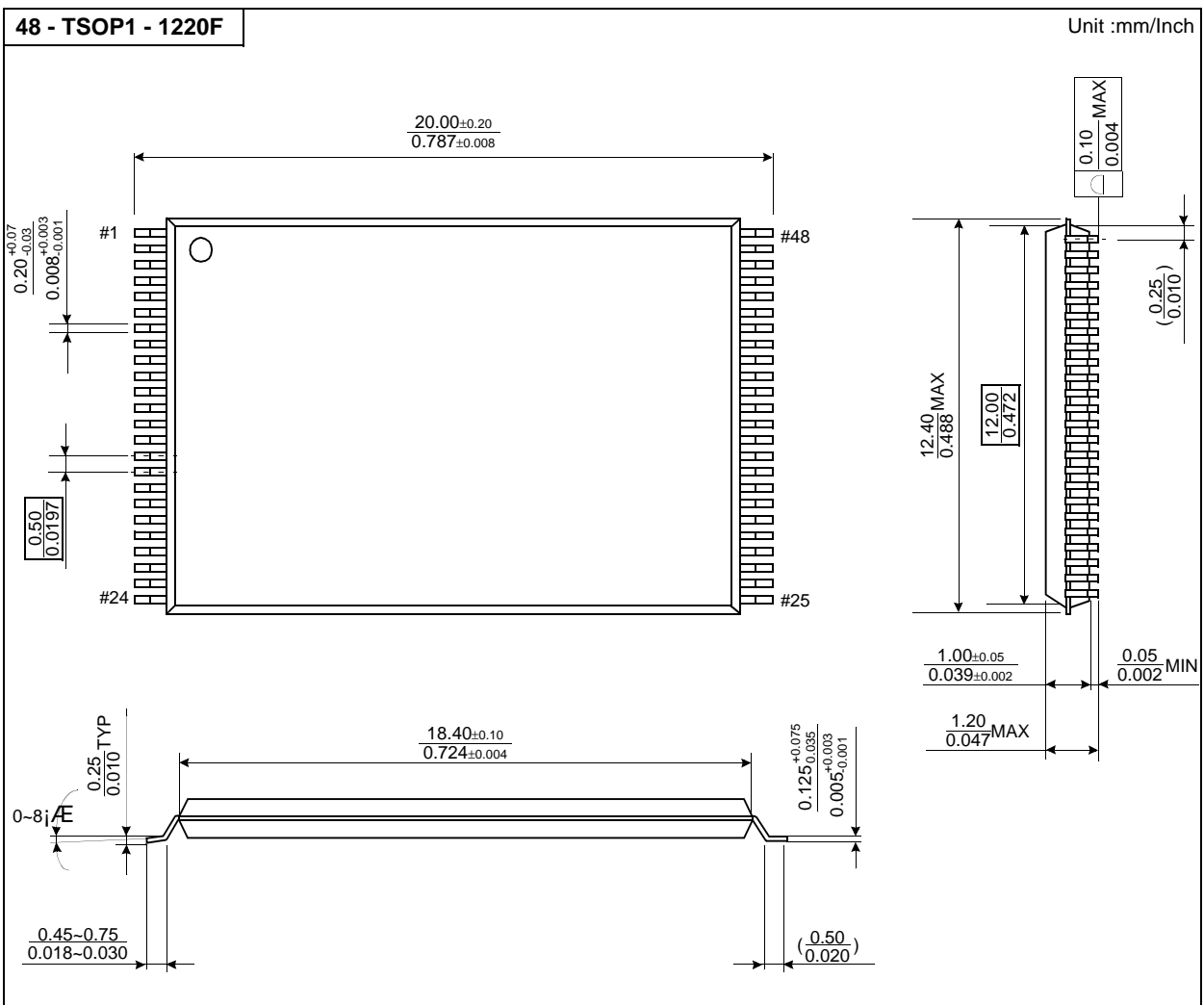

K9F5608U0C-VCB0,VIB0,FCB0,FIB0
 K9F5608Q0C-DCB0,DIB0,HCBO,HIB0
 K9F5608U0C-YCB0,YIB0,PCB0,PIB0
 K9F5608U0C-DCB0,DIB0,HCBO,HIB0

K9F5616Q0C-DCB0,DIB0,HCBO,HIB0
 K9F5616U0C-YCB0,YIB0,PCB0,PIB0
 K9F5616U0C-DCB0,DIB0,HCBO,HIB0

FLASH MEMORY

PIN CONFIGURATION (WSOP1)

K9F5608U0C-VCB0,FCB0/VIB0,FIB0

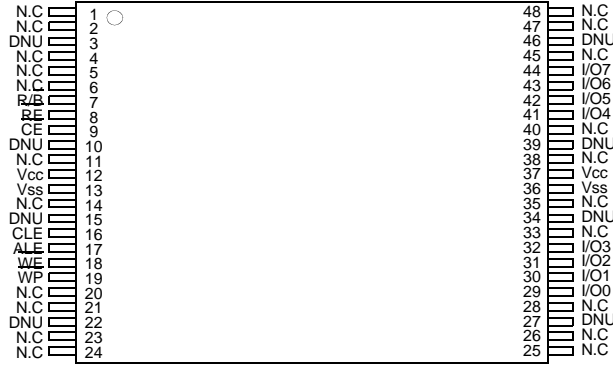

PACKAGE DIMENSIONS

48-PIN LEAD/LEAD FREE PLASTIC VERY VERY THIN SMALL OUT-LINE PACKAGE TYPE (I)

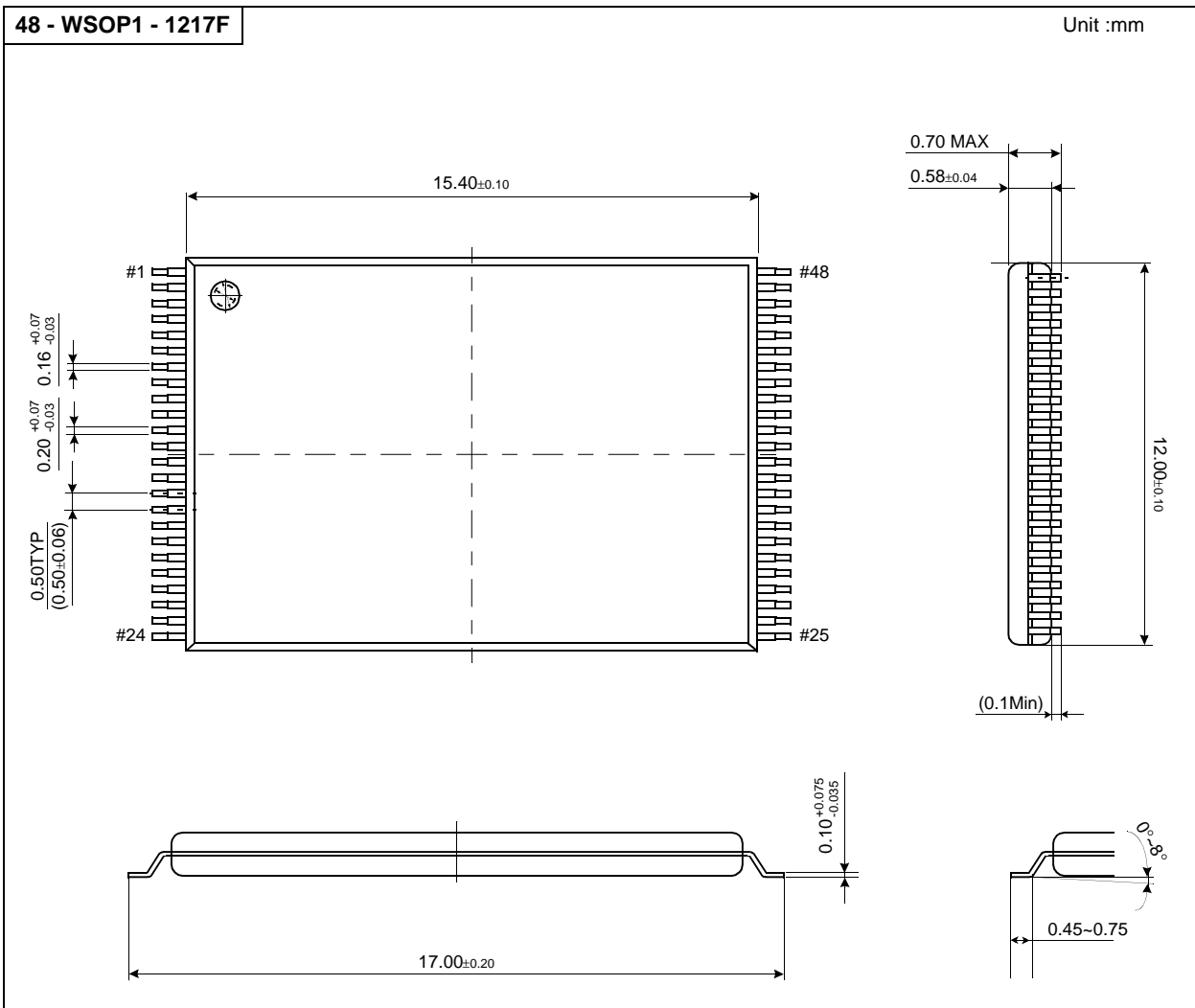

ELECTRONICS

PIN DESCRIPTION

Pin NAME	Pin Function
I/O ₀ ~ I/O ₇ (K9F5608X0C) I/O ₀ ~ I/O ₁₅ (K9F5616X0C)	DATA INPUTS/OUTPUTS The I/O pins are used to input command, address and data, and to output data during read operations. The I/O pins float to high-z when the chip is deselected or when the outputs are disabled. I/O ₈ ~ I/O ₁₅ are used only in X16 organization device. Since command input and address input are x8 operation, I/O ₈ ~ I/O ₁₅ are not used to input command & address. I/O ₈ ~ I/O ₁₅ are used only for data input and output.
CLE	COMMAND LATCH ENABLE The CLE input controls the activating path for commands sent to the command register. When active high, commands are latched into the command register through the I/O ports on the rising edge of the WE signal.
ALE	ADDRESS LATCH ENABLE The ALE input controls the activating path for address to the internal address registers. Addresses are latched on the rising edge of WE with ALE high.
\overline{CE}	CHIP ENABLE The \overline{CE} input is the device selection control. When the device is in the Busy state, \overline{CE} high is ignored, and the device does not return to standby mode in program or erase operation. Regarding \overline{CE} control during read operation, refer to 'Page read' section of Device operation .
\overline{RE}	READ ENABLE The \overline{RE} input is the serial data-out control, and when active drives the data onto the I/O bus. Data is valid tREA after the falling edge of RE which also increments the internal column address counter by one.
\overline{WE}	WRITE ENABLE The WE input controls writes to the I/O port. Commands, address and data are latched on the rising edge of the WE pulse.
\overline{WP}	WRITE PROTECT The WP pin provides inadvertent write/erase protection during power transitions. The internal high voltage generator is reset when the WP pin is active low. When LOCKPRE is a logic high and WP is a logic low, the all blocks go to lock state.
R/ \overline{B}	READY/BUSY OUTPUT The R/B output indicates the status of the device operation. When low, it indicates that a program, erase or random read operation is in process and returns to high state upon completion. It is an open drain output and does not float to high-z condition when the chip is deselected or when outputs are disabled.
VccQ	OUTPUT BUFFER POWER VccQ is the power supply for Output Buffer. VccQ is internally connected to Vcc, thus should be biased to Vcc.
Vcc	POWER Vcc is the power supply for device.
Vss	GROUND
N.C	NO CONNECTION Lead is not internally connected.
DNU	DO NOT USE Leave it disconnected
LOCKPRE	LOCK MECHANISM & POWER-ON AUTO-READ ENABLE To Enable and disable the Lock mechanism and Power On Auto Read. When LOCKPRE is a logic high, Block Lock mode and Power-On Auto-Read mode are enabled, and when LOCKPRE is a logic low, Block Lock mode and Power-On Auto-Read mode are disabled. Power-On Auto-Read mode is available only on 3.3V device(K9F56XXU0C) Don't leave it N.C. Not using LOCK MECHANISM & POWER-ON AUTO-READ, connect it Vss.

NOTE : Connect all Vcc and Vss pins of each device to common power supply outputs.
 Do not leave Vcc or Vss disconnected.

Figure 1-1. K9F5608X0C (X8) FUNCTIONAL BLOCK DIAGRAM

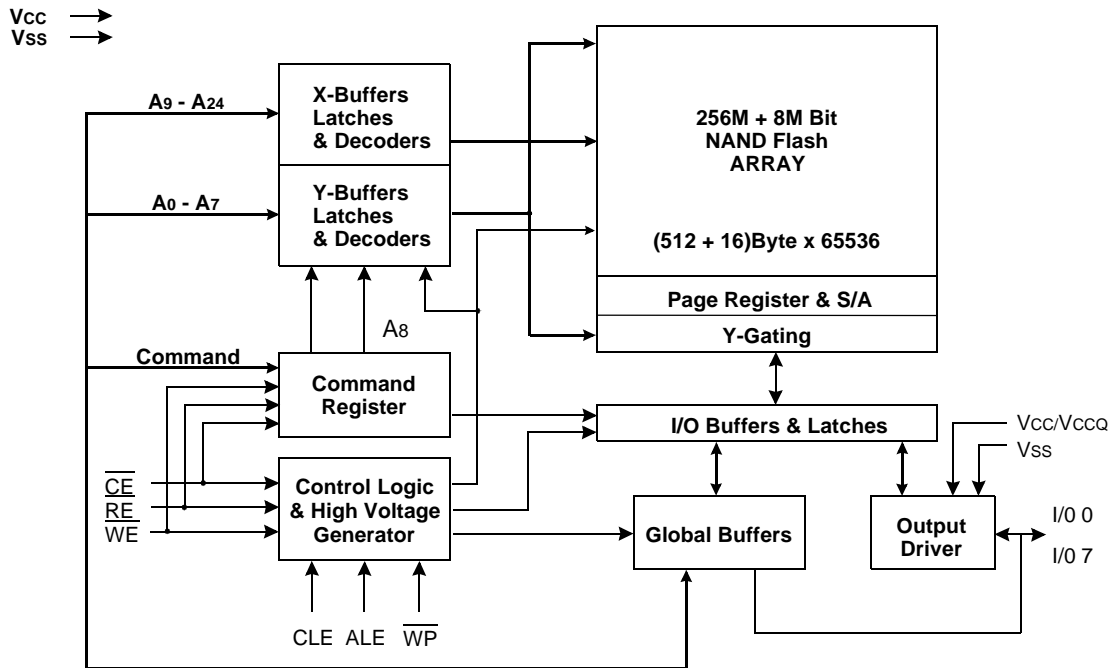
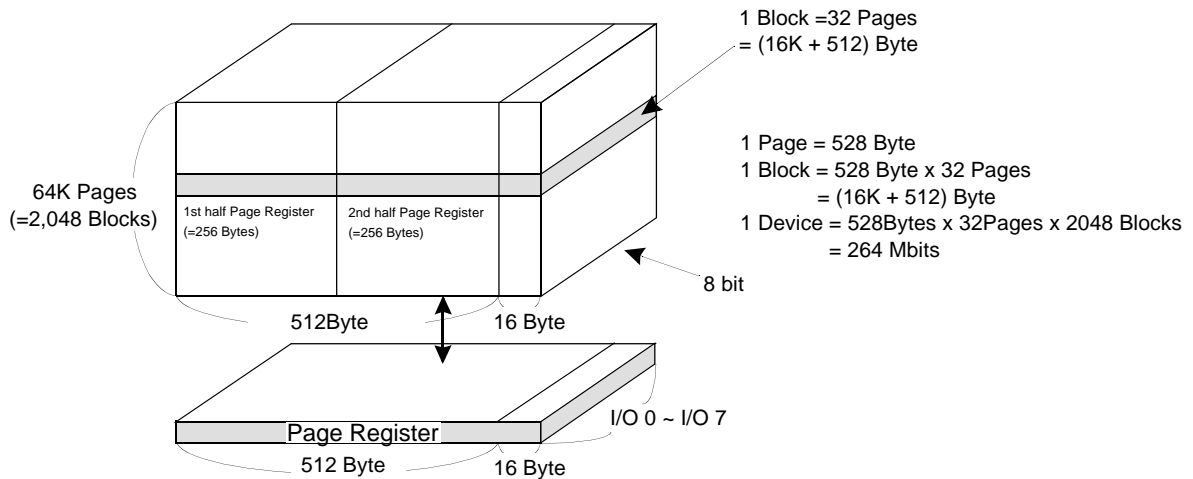

Figure 2-1. K9F5608X0C (X8) ARRAY ORGANIZATION



	I/O 0	I/O 1	I/O 2	I/O 3	I/O 4	I/O 5	I/O 6	I/O 7	
1st Cycle	A0	A1	A2	A3	A4	A5	A6	A7	Column Address
2nd Cycle	A9	A10	A11	A12	A13	A14	A15	A16	Row Address
3rd Cycle	A17	A18	A19	A20	A21	A22	A23	A24	(Page Address)

NOTE : Column Address : Starting Address of the Register.
 00h Command(Read) : Defines the starting address of the 1st half of the register.
 01h Command(Read) : Defines the starting address of the 2nd half of the register.
 * A8 is set to "Low" or "High" by the 00h or 01h Command.
 * The device ignores any additional input of address cycles than required.

Figure 1-2. K9F5616X0C (X16) FUNCTIONAL BLOCK DIAGRAM

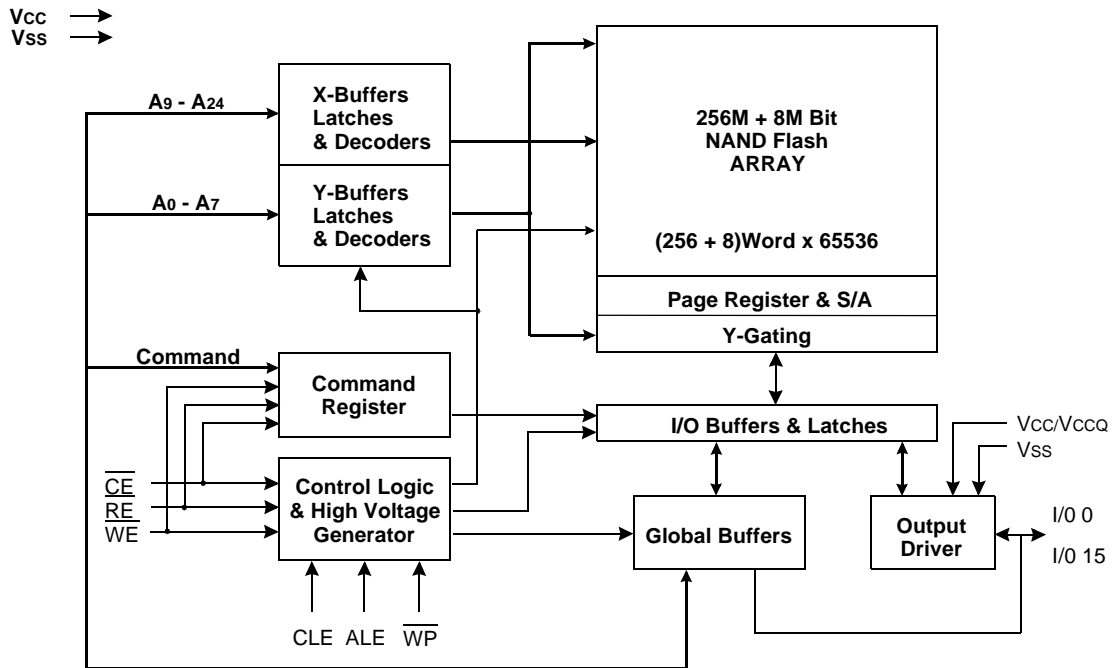
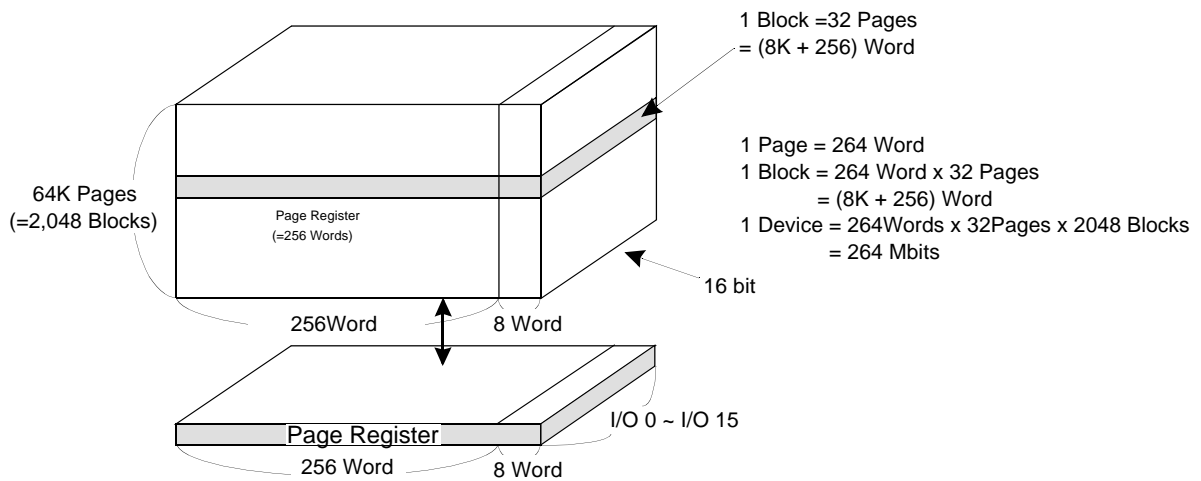

Figure 2-2. K9F5616X0C (X16) ARRAY ORGANIZATION



	I/O 0	I/O 1	I/O 2	I/O 3	I/O 4	I/O 5	I/O 6	I/O 7	I/O8 to 15	
1st Cycle	A0	A1	A2	A3	A4	A5	A6	A7	L*	Column Address
2nd Cycle	A9	A10	A11	A12	A13	A14	A15	A16	A17	Row Address
3rd Cycle	A17	A18	A19	A20	A21	A22	A23	A24	L*	(Page Address)

NOTE : Column Address : Starting Address of the Register.

* L must be set to "Low".

PRODUCT INTRODUCTION

The K9F56XXX0C is a 264Mbit(276,824,064 bit) memory organized as 65,536 rows(pages) by 528(X8 device) or 264(X16 device) columns. Spare eight columns are located from column address of 512~527(X8 device) or 256~263(X16 device). A 528-byte(X8 device) or 264-word(X16 device) data register is connected to memory cell arrays accommodating data transfer between the I/O buffers and memory during page read and page program operations. The memory array is made up of 16 cells that are serially connected to form a NAND structure. Each of the 16 cells resides in a different page. A block consists of two NAND structures. A NAND structure consists of 16 cells. Total 16896 NAND cells reside in a block. The array organization is shown in Figure 2-1,2-2. The program and read operations are executed on a page basis, while the erase operation is executed on a block basis. The memory array consists of 2048 separately erasable 16K-Byte(X8 device) or 8K-Word(X16 device) blocks. It indicates that the bit by bit erase operation is prohibited on the K9F56XXX0C.

The K9F56XXX0C has addresses multiplexed into 8 I/Os(X16 device case : lower 8 I/Os). K9F5616X0C allows sixteen bit wide data transport into and out of page registers. This scheme dramatically reduces pin counts while providing high performance and allows systems upgrades to future densities by maintaining consistency in system board design. Command, address and data are all written through I/O's by bringing WE to low while CE is low. Data is latched on the rising edge of WE. Command Latch Enable(CLE) and Address Latch Enable(ALE) are used to multiplex command and address respectively, via the I/O pins. Some commands require one bus cycle. For example, Reset command, Read command, Status Read command, etc require just one cycle bus. Some other commands like Page Program and Copy-back Program and Block Erase, require two cycles: one cycle for setup and the other cycle for execution. The 32M-byte(X8 device) or 16M-word(X16 device) physical space requires 24 addresses, thereby requiring three cycles for word-level addressing: column address, low row address and high row address, in that order. Page Read and Page Program need the same three address cycles following the required command input. In Block Erase operation, however, only the two row address cycles are used. Device operations are selected by writing specific commands into the command register. Table 1 defines the specific commands of the K9F56XXX0C.

The device includes one block sized OTP(One Time Programmable), which can be used to increase system security or to provide identification capabilities. Detailed information can be obtained by contact with Samsung.

Table 1. COMMAND SETS

Function	1st. Cycle	2nd. Cycle	Acceptable Command during Busy
Read 1	00h/01h ⁽¹⁾	-	
Read 2	50h	-	
Read ID	90h	-	
Reset	FFh	-	O
Page Program	80h	10h	
Copy-Back Program	00h	8Ah	
Lock	2Ah	-	
Unlock	23h	24h	
Lock-tight	2Ch	-	
Read Block Lock Status	7Ah	-	
Block Erase	60h	D0h	
Read Status	70h	-	O

NOTE : 1. The 01h command is available only on X8 device(K9F5608X0C).

Caution : Any undefined command inputs are prohibited except for above command set of Table 1.

ABSOLUTE MAXIMUM RATINGS

Parameter		Symbol	Rating		Unit
			K9F56XXQ0C(1.8V)	K9F56XXU0C(3.3V)	
Voltage on any pin relative to Vss		VIN/OUT	-0.6 to + 2.45	-0.6 to + 4.6	V
		Vcc	-0.2 to + 2.45	-0.6 to + 4.6	
		Vccq	-0.2 to + 2.45	-0.6 to + 4.6	
Temperature Under Bias	K9F56XXX0C-XCB0	TBIAS	-10 to +125		°C
	K9F56XXX0C-XIB0		-40 to +125		
Storage Temperature	K9F56XXX0C-XCB0	TSTG	-65 to +150		°C
	K9F56XXX0C-XIB0				
Short Circuit Current		Ios	5		mA

NOTE :

1. Minimum DC voltage is -0.6V on input/output pins. During transitions, this level may undershoot to -2.0V for periods <30ns. Maximum DC voltage on input/output pins is Vcc+0.3V which, during transitions, may overshoot to Vcc+2.0V for periods <20ns.
2. Permanent device damage may occur if ABSOLUTE MAXIMUM RATINGS are exceeded. Functional operation should be restricted to the conditions as detailed in the operational sections of this data sheet. Exposure to absolute maximum rating conditions for extended periods may affect reliability.

RECOMMENDED OPERATING CONDITIONS

(Voltage reference to GND, K9F56XXX0C-XCB0 :TA=0 to 70°C, K9F56XXX0C-XIB0:TA=-40 to 85°C)

Parameter	Symbol	K9F56XXQ0C(1.8V)			K9F56XXU0C(3.3V)			Unit
		Min	Typ.	Max	Min	Typ.	Max	
Supply Voltage	Vcc	1.70	1.8	1.95	2.7	3.3	3.6	V
Supply Voltage	Vccq	1.70	1.8	1.95	2.7	3.3	3.6	V
Supply Voltage	Vss	0	0	0	0	0	0	V

DC AND OPERATING CHARACTERISTICS(Recommended operating conditions otherwise noted.)

Parameter		Symbol	Test Conditions	K9F56XXQ0C(1.8V)			K9F56XXU0C(3.3V)			Unit
				Min	Typ	Max	Min	Typ	Max	
Operating Current	Sequential Read	Icc1	tRC=50ns, CE=VIL IOUT=0mA	-	8	15	-	10	20	mA
	Program	Icc2	-	-	8	15	-	10	25	
	Erase	Icc3	-	-	8	15	-	10	25	
Stand-by Current(TTL)		Isb1	CE=VIH, WP=0V/Vcc	-	-	1	-	-	1	µA
Stand-by Current(CMOS)		Isb2	CE=Vcc-0.2, WP=0V/Vcc	-	10	50	-	10	50	
Input Leakage Current		ILI	VIN=0 to Vcc(max)	-	-	±10	-	-	±10	µA
Output Leakage Current		ILO	VOUT=0 to Vcc(max)	-	-	±10	-	-	±10	
Input High Voltage		VIH	I/O pins	Vccq-0.4	-	Vccq+0.3	2.0	-	Vccq+0.3	V
			Except I/O pins	Vcc-0.4	-	Vcc+0.3	2.0	-	Vcc+0.3	
Input Low Voltage, All inputs		VIL	-	-0.3	-	0.4	-0.3	-	0.8	V
Output High Voltage Level		VOH	K9F56XXQ0C :IOH=-100µA K9F56XXU0C :IOH=-400µA	Vccq-0.1	-	-	2.4	-	-	
Output Low Voltage Level		VOL	K9F56XXQ0C :IOL=100µA K9F56XXU0C :IOL=2.1mA	-	-	0.1	-	-	0.4	
Output Low Current(R/B)		IOL(R/B)	K9F56XXQ0C :VOL=0.1V K9F56XXU0C :VOL=0.4V	3	4	-	8	10	-	mA

K9F5608U0C-VCB0,VIB0,FCB0,FIB0
 K9F5608Q0C-DCB0,DIB0,HCBO,HIB0
 K9F5608U0C-YCB0,YIB0,PCB0,PIB0
 K9F5608U0C-DCB0,DIB0,HCBO,HIB0

K9F5616Q0C-DCB0,DIB0,HCBO,HIB0
 K9F5616U0C-YCB0,YIB0,PCB0,PIB0
 K9F5616U0C-DCB0,DIB0,HCBO,HIB0

FLASH MEMORY

VALID BLOCK

Parameter	Symbol	Min	Typ.	Max	Unit
Valid Block Number	NvB	2013	-	2048	Blocks

NOTE :

- The K9F56XXX0C may include invalid blocks when first shipped. Additional invalid blocks may develop while being used. The number of valid blocks is presented with both cases of invalid blocks considered. Invalid blocks are defined as blocks that contain one or more bad bits. Do not erase or program factory-marked bad blocks. Refer to the attached technical notes for a appropriate management of invalid blocks.
- The 1st block, which is placed on 00h block address, is fully guaranteed to be a valid block, does not require Error Correction.
- Minimum 1004 valid blocks are guaranteed for each contiguous 128Mb memory space.**

AC TEST CONDITION

(K9F56XXX0C-XCB0 :TA=0 to 70°C, K9F56XXX0C-XIB0:TA=-40 to 85°C

K9F56XXQ0C : Vcc=1.70V~1.95V , K9F56XXU0C : Vcc=2.7V~3.6V unless otherwise noted)

Parameter	K9F56XXQ0C	K9F56XXU0C
Input Pulse Levels	0V to VccQ	0.4V to 2.4V
Input Rise and Fall Times	5ns	5ns
Input and Output Timing Levels	VccQ/2	1.5V
K9F56XXQ0C:Output Load (VccQ:1.8V +/-10%) K9F56XXU0C:Output Load (VccQ:3.0V +/-10%)	1 TTL GATE and CL=30pF	1 TTL GATE and CL=50pF
K9F56XXU0C:Output Load (VccQ:3.3V +/-10%)	-	1 TTL GATE and CL=100pF

CAPACITANCE(TA=25°C, VCC=1.8V/3.3V, f=1.0MHz)

Item	Symbol	Test Condition	Min	Max	Unit
Input/Output Capacitance	C _{I/O}	V _{IL} =0V	-	10	pF
Input Capacitance	C _{IN}	V _{IN} =0V	-	10	pF

NOTE : Capacitance is periodically sampled and not 100% tested.

MODE SELECTION

CLE	ALE	CE	WE	RE	PRE	WP	Mode	
H	L	L		H	X	X	Read Mode	Command Input
L	H	L		H	X	X		Address Input(3clock)
H	L	L		H	X	H	Write Mode	Command Input
L	H	L		H	X	H		Address Input(3clock)
L	L	L		H	X	H	Data Input	
L	L	L	H		X	X	Data Output	
X	X	X	X	H	X	X	During Read(Busy) on K9F5608U0C_Y,P or K9F5608U0C_V,F	
L	L	L	H	H	X	X	During Read(Busy) on the devices except K9F5608U0C_Y,P and K9F5608U0C_V,F	
X	X	X	X	X	X	H	During Program(Busy)	
X	X	X	X	X	X	H	During Erase(Busy)	
X	X ⁽¹⁾	X	X	X	X	L	Write Protect	
X	X	H	X	X	0V/Vcc ⁽²⁾	0V/Vcc ⁽²⁾	Stand-by	

NOTE : 1. X can be V_{IL} or V_{IH}.

2. WP should be biased to CMOS high or CMOS low for standby.

Program/Erase Characteristics

Parameter	Symbol	Min	Typ	Max	Unit
Program Time	t _{PROG}	-	200	500	μs
Dummy Busy Time for the Lock or Lock-tight Block	t _{LSY}	-	5	10	μs
Number of Partial Program Cycles in the Same Page	Main Array	-	-	2	cycles
	Spare Array	-	-	3	cycles
Block Erase Time	t _{BERS}	-	2	3	ms

AC Timing Characteristics for Command / Address / Data Input

Parameter	Symbol	Min	Max	Unit
CLE Set-up Time	tCLS	0	-	ns
CLE Hold Time	tCLH	10	-	ns
$\overline{\text{CE}}$ Setup Time	tCS	0	.-	ns
$\overline{\text{CE}}$ Hold Time	tCH	10	-	ns
$\overline{\text{WE}}$ Pulse Width	tWP	25 ⁽¹⁾	-	ns
ALE Setup Time	tALS	0	-	ns
ALE Hold Time	tALH	10	-	ns
Data Setup Time	tDS	20	-	ns
Data Hold Time	tDH	10	-	ns
Write Cycle Time	tWC	45	-	ns
$\overline{\text{WE}}$ High Hold Time	tWH	15	-	ns

NOTE :

1. If tCS is set less than 10ns, tWP must be minimum 35ns, otherwise, tWP may be minimum 25ns.

AC Characteristics for Operation

Parameter	Symbol	Min	Max	Unit	
Data Transfer from Cell to Register	tR	-	10	μ s	
ALE to $\overline{\text{RE}}$ Delay	tAR	10	-	ns	
CLE to $\overline{\text{RE}}$ Delay	tCLR	10	-	ns	
Ready to $\overline{\text{RE}}$ Low	tRR	20	-	ns	
$\overline{\text{RE}}$ Pulse Width	tRP	25	-	ns	
$\overline{\text{WE}}$ High to Busy	tWB	-	100	ns	
Read Cycle Time	tRC	50	-	ns	
$\overline{\text{CE}}$ Access Time	tCEA	-	45	ns	
$\overline{\text{RE}}$ Access Time	tREA	-	30	ns	
$\overline{\text{RE}}$ High to Output Hi-Z	tRHZ	-	30	ns	
$\overline{\text{CE}}$ High to Output Hi-Z	tCHZ	-	20	ns	
$\overline{\text{RE}}$ or $\overline{\text{CE}}$ High to Output hold	tOH	15	-	ns	
$\overline{\text{RE}}$ High Hold Time	tREH	15	-	ns	
Output Hi-Z to $\overline{\text{RE}}$ Low	tIR	0	-	ns	
$\overline{\text{WE}}$ High to $\overline{\text{RE}}$ Low	tWHR1	60	-	ns	
$\overline{\text{WE}}$ High to $\overline{\text{RE}}$ Low in Block Lock Mode	tWHR2	100	-	ns	
Device Resetting Time(Read/Program/Erase)	tRST	-	5/10/500 ⁽¹⁾	μ s	
K9F5608U0C- Y,V,P,F only	Last $\overline{\text{RE}}$ High to Busy(at sequential read)	tRB	-	100	ns
	$\overline{\text{CE}}$ High to Ready(in case of interception by $\overline{\text{CE}}$ at read)	tCRY	-	50 +tr(R/B) ⁽³⁾	ns
	$\overline{\text{CE}}$ High Hold Time(at the last serial read) ⁽²⁾	tCEH	100	-	ns

NOTE :

1. If reset command(FFh) is written at Ready state, the device goes into Busy for maximum 5us.
2. To break the sequential read cycle, $\overline{\text{CE}}$ must be held high for longer time than tCEH.
3. The time to Ready depends on the value of the pull-up resistor tied R/B pin.

NAND Flash Technical Notes

Invalid Block(s)

Invalid blocks are defined as blocks that contain one or more invalid bits whose reliability is not guaranteed by Samsung. The information regarding the invalid block(s) is so called as the invalid block information. Devices with invalid block(s) have the same quality level as devices with all valid blocks and have the same AC and DC characteristics. An invalid block(s) does not affect the performance of valid block(s) because it is isolated from the bit line and the common source line by a select transistor. The system design must be able to mask out the invalid block(s) via address mapping. The 1st block, which is placed on 00h block address, is fully guaranteed to be a valid block, does not require Error Correction.

Identifying Invalid Block(s)

All device locations are erased(FFh) except locations where the invalid block(s) information is written prior to shipping. The invalid block(s) status is defined by the 6th byte(X8 device) or 1st word(X16 device) in the spare area. Samsung makes sure that either the 1st or 2nd page of every invalid block has non-FFh(X8 device) or non-FFFFh(X16 device) data at the column address of 517(X8 device) or 256 and 261(X16 device). Since the invalid block information is also erasable in most cases, it is impossible to recover the information once it has been erased. Therefore, the system must be able to recognize the invalid block(s) based on the original invalid block information and create the invalid block table via the following suggested flow chart(Figure 3). Any intentional erasure of the original invalid block information is prohibited.

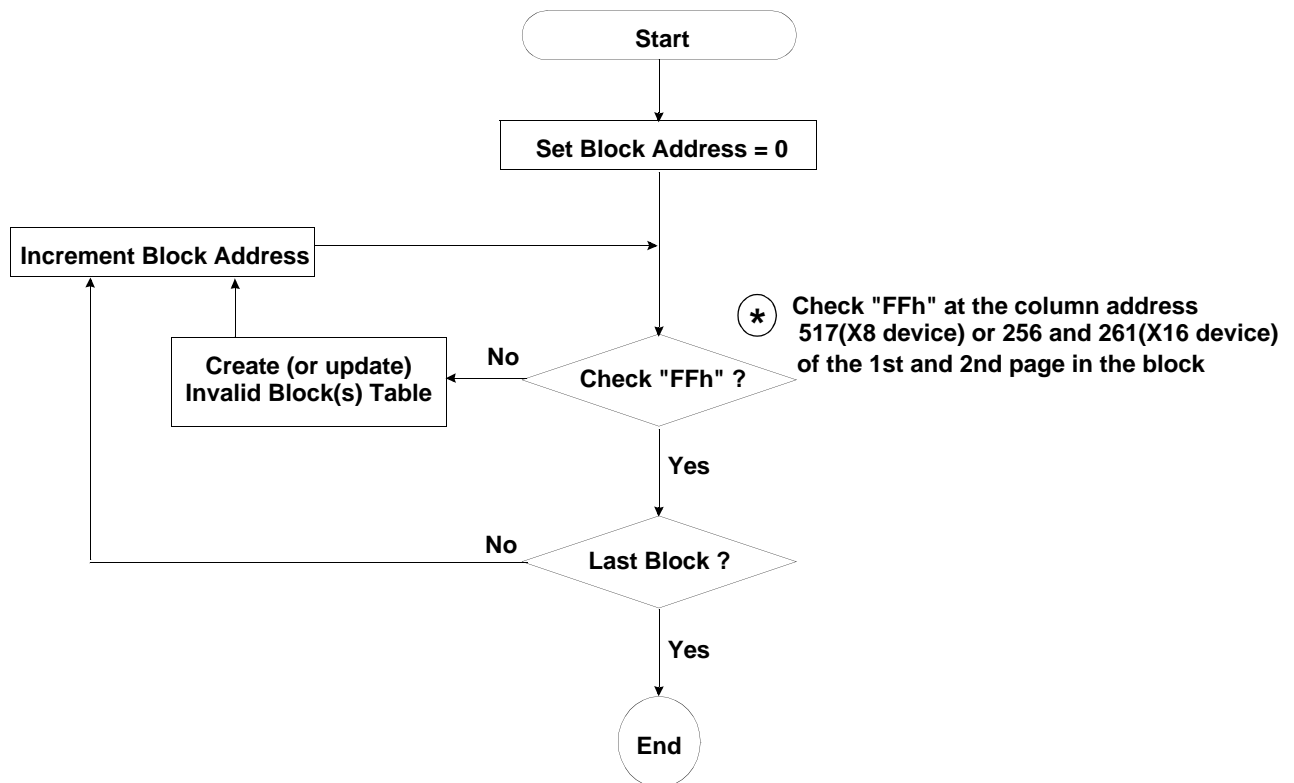

Figure 3. Flow chart to create invalid block table.

NAND Flash Technical Notes (Continued)

Error in write or read operation

Within its life time, the additional invalid blocks may develop with NAND Flash memory. Refer to the qualification report for the actual data. The following possible failure modes should be considered to implement a highly reliable system. In the case of status read failure after erase or program, block replacement should be done. Because program status fail during a page program does not affect the data of the other pages in the same block, block replacement can be executed with a page-sized buffer by finding an erased empty block and reprogramming the current target data and copying the rest of the replaced block. To improve the efficiency of memory space, it is recommended that the read or verification failure due to single bit error be reclaimed by ECC without any block replacement. The said additional block failure rate does not include those reclaimed blocks.

	Failure Mode	Detection and Countermeasure sequence
Write	Erase Failure	Status Read after Erase --> Block Replacement
	Program Failure	Status Read after Program --> Block Replacement Read back (Verify after Program) --> Block Replacement or ECC Correction
Read	Single Bit Failure	Verify ECC -> ECC Correction

ECC : Error Correcting Code --> Hamming Code etc.
 Example) 1bit correction & 2bit detection

Program Flow Chart

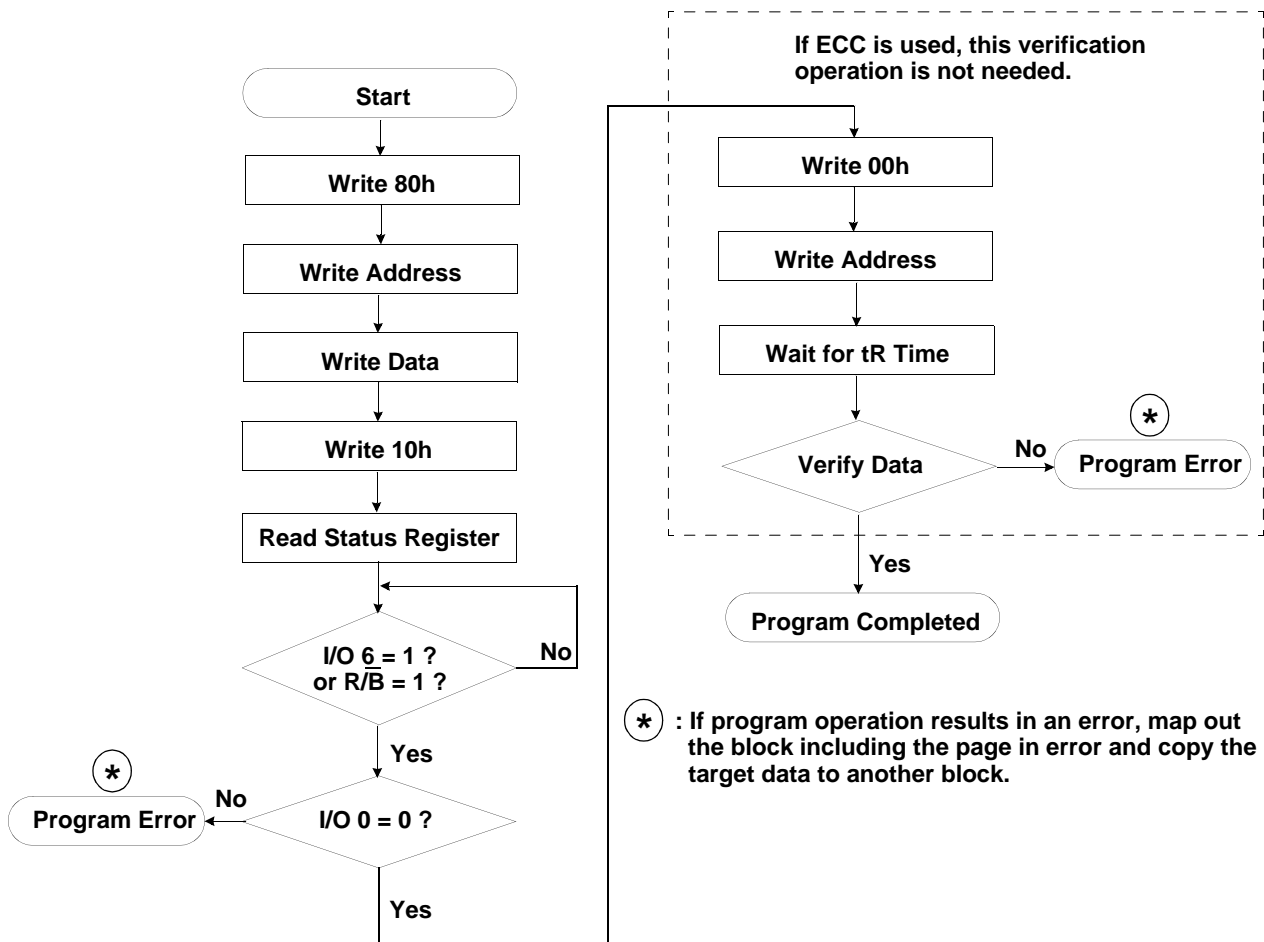

NAND Flash Technical Notes (Continued)

Erase Flow Chart

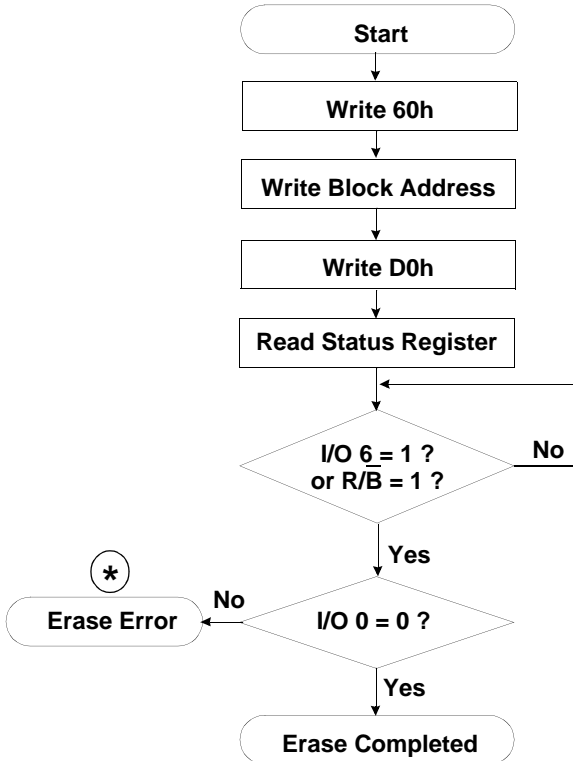

Read Flow Chart

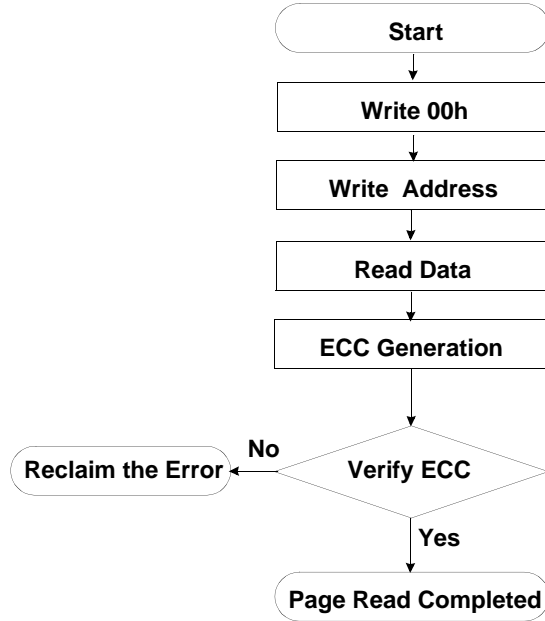

* : If erase operation results in an error, map out the failing block and replace it with another block.

Block Replacement

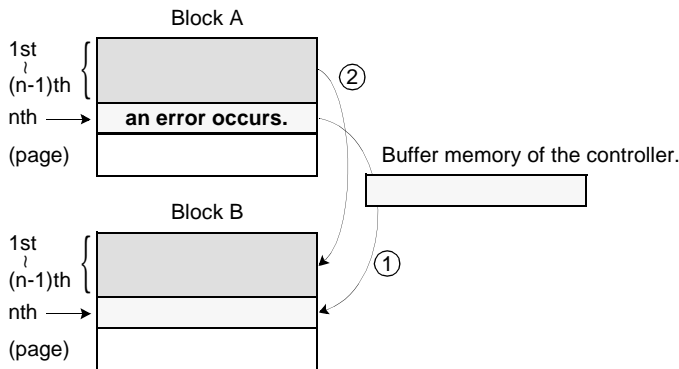

* Step1

When an error happens in the nth page of the Block 'A' during erase or program operation.

* Step2

Copy the nth page data of the Block 'A' in the buffer memory to the nth page of another free block. (Block 'B')

* Step3

Then, copy the data in the 1st ~ (n-1)th page to the same location of the Block 'B'.

* Step4

Do not further erase Block 'A' by creating an 'invalid Block' table or other appropriate scheme.

Pointer Operation of K9F5608X0C(X8)

Samsung NAND Flash has three address pointer commands as a substitute for the two most significant column addresses. '00h' command sets the pointer to 'A' area(0~255byte), '01h' command sets the pointer to 'B' area(256~511byte), and '50h' command sets the pointer to 'C' area(512~527byte). With these commands, the starting column address can be set to any of a whole page(0~527byte). '00h' or '50h' is sustained until another address pointer command is inputted. '01h' command, however, is effective only for one operation. After any operation of Read, Program, Erase, Reset, Power_Up is executed once with '01h' command, the address pointer returns to 'A' area by itself. To program data starting from 'A' or 'C' area, '00h' or '50h' command must be inputted before '80h' command is written. A complete read operation prior to '80h' command is not necessary. To program data starting from 'B' area, '01h' command must be inputted right before '80h' command is written.

Table 2. Destination of the pointer

Command	Pointer position	Area
00h	0 ~ 255 byte	1st half array(A)
01h	256 ~ 511 byte	2nd half array(B)
50h	512 ~ 527 byte	spare array(C)

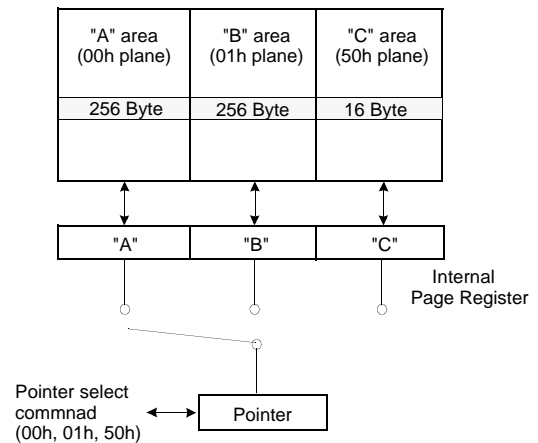
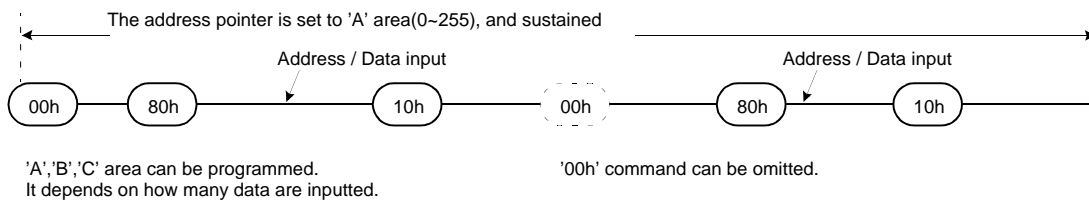
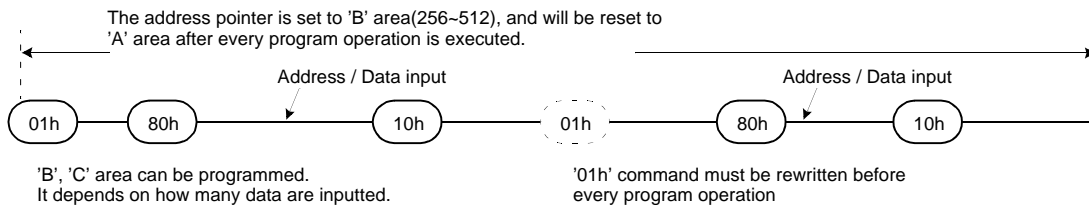

Figure 4. Block Diagram of Pointer Operation

(1) Command input sequence for programming 'A' area



(2) Command input sequence for programming 'B' area



(3) Command input sequence for programming 'C' area

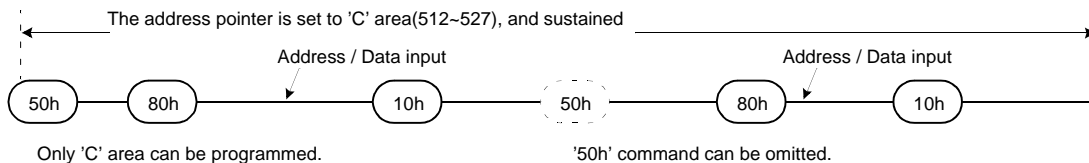

Pointer Operation of K9F5616X0C(X16)

Samsung NAND Flash has two address pointer commands as a substitute for the most significant column address. '00h' command sets the pointer to 'A' area(0~255word), and '50h' command sets the pointer to 'B' area(256~263word). With these commands, the starting column address can be set to any of a whole page(0~263word). '00h' or '50h' is sustained until another address pointer command is inputted. To program data starting from 'A' or 'B' area, '00h' or '50h' command must be inputted before '80h' command is written. A complete read operation prior to '80h' command is not necessary.

Table 3. Destination of the pointer

Command	Pointer position	Area
00h	0 ~ 255 word	main array(A)
50h	256 ~ 263 word	spare array(B)

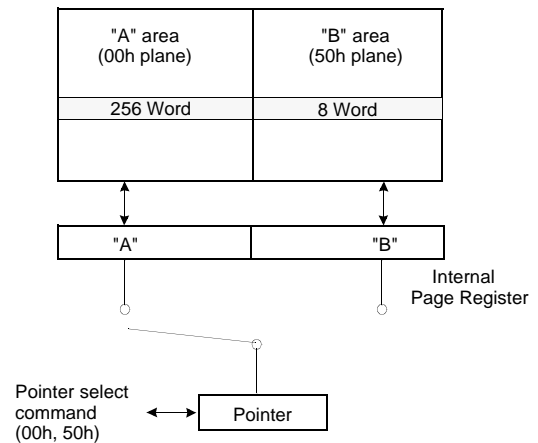
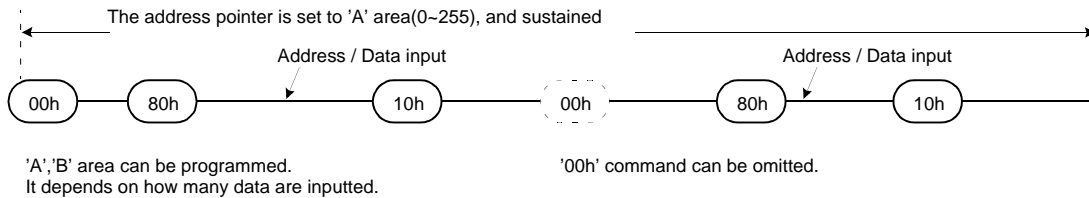
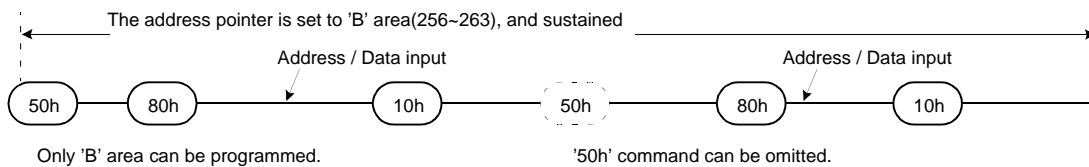

Figure 5. Block Diagram of Pointer Operation

(1) Command input sequence for programming 'A' area



(2) Command input sequence for programming 'B' area



System Interface Using $\overline{\text{CE}}$ don't-care.

For an easier system interface, $\overline{\text{CE}}$ may be inactive during the data-loading or sequential data-reading as shown below. The internal 528byte/264word page registers are utilized as separate buffers for this operation and the system design gets more flexible. In addition, for voice or audio applications which use slow cycle time on the order of u-seconds, de-activating $\overline{\text{CE}}$ during the data-loading and reading would provide significant savings in power consumption.

Figure 6. Program Operation with $\overline{\text{CE}}$ don't-care.

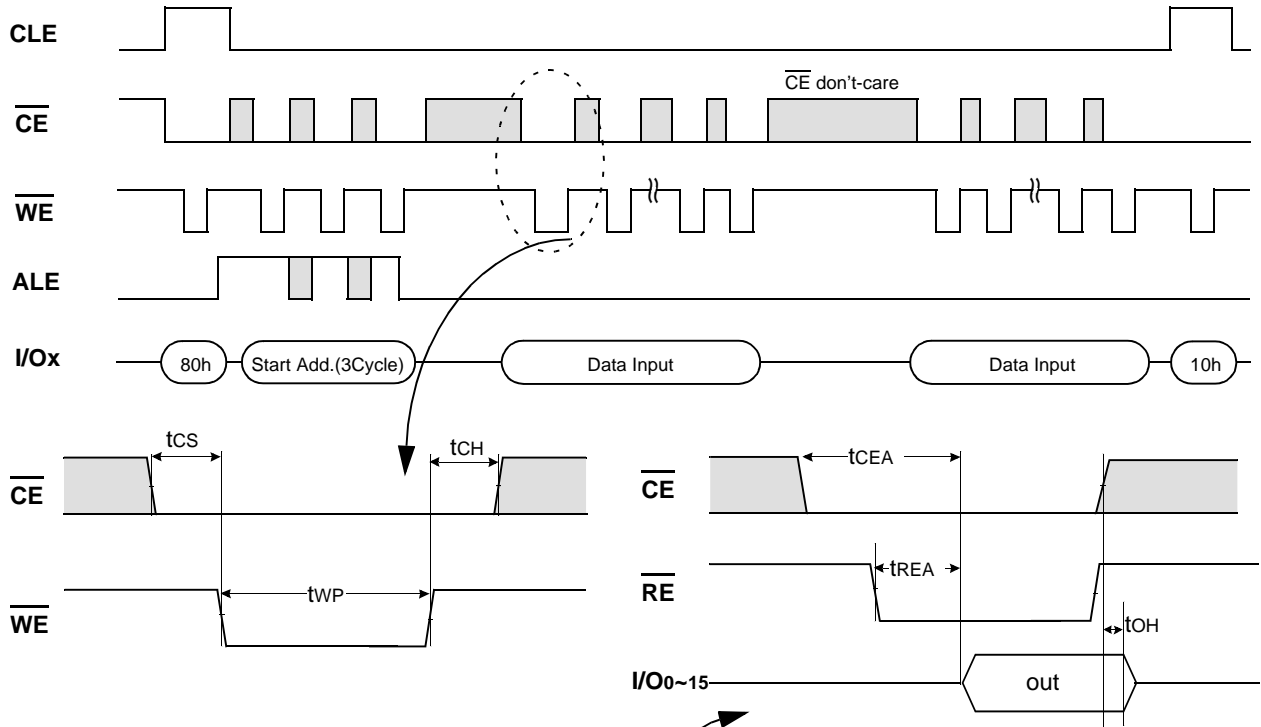
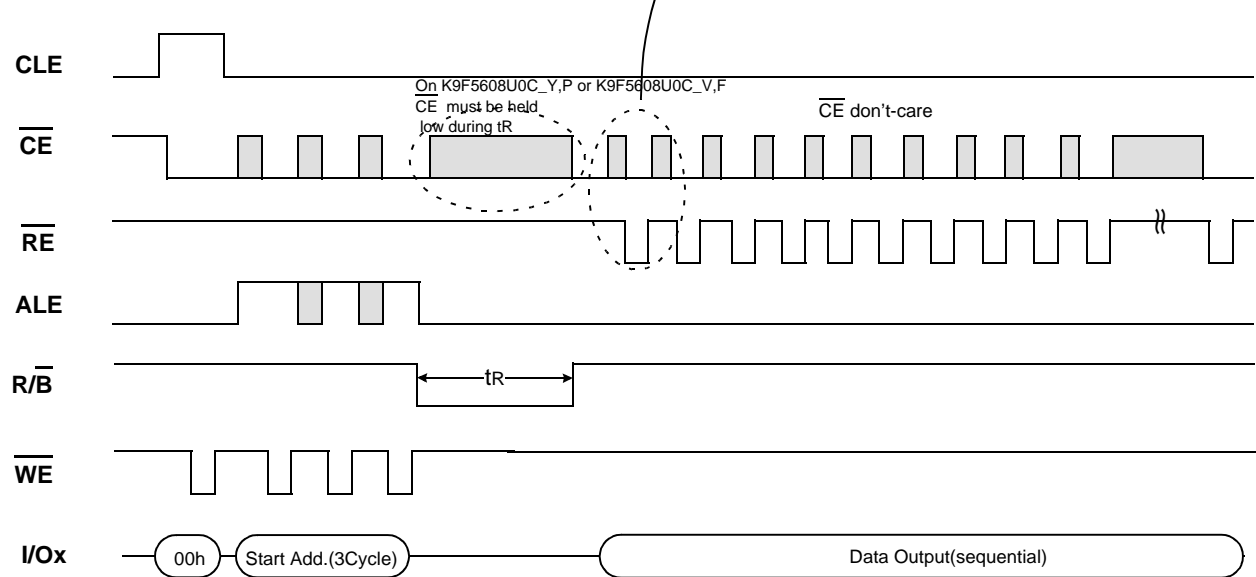

Figure 7. Read Operation with $\overline{\text{CE}}$ don't-care.



K9F5608U0C-VCB0,VIB0,FCB0,FIB0
 K9F5608Q0C-DCB0,DIB0,HCB0,HIB0
 K9F5608U0C-YCB0,YIB0,PCB0,PIB0
 K9F5608U0C-DCB0,DIB0,HCB0,HIB0

K9F5616Q0C-DCB0,DIB0,HCB0,HIB0
 K9F5616U0C-YCB0,YIB0,PCB0,PIB0
 K9F5616U0C-DCB0,DIB0,HCB0,HIB0

FLASH MEMORY

Device	I/O	DATA
	I/Ox	Data In/Out
K9F5608X0C(X8 device)	I/O 0 ~ I/O 7	~528byte
K9F5616X0C(X16 device)	I/O 0 ~ I/O 15 ¹⁾	~264word

NOTE: 1. I/O8~15 must be set to "0" during command or address input.
 2. I/O8~15 are used only for data bus.

* Command Latch Cycle

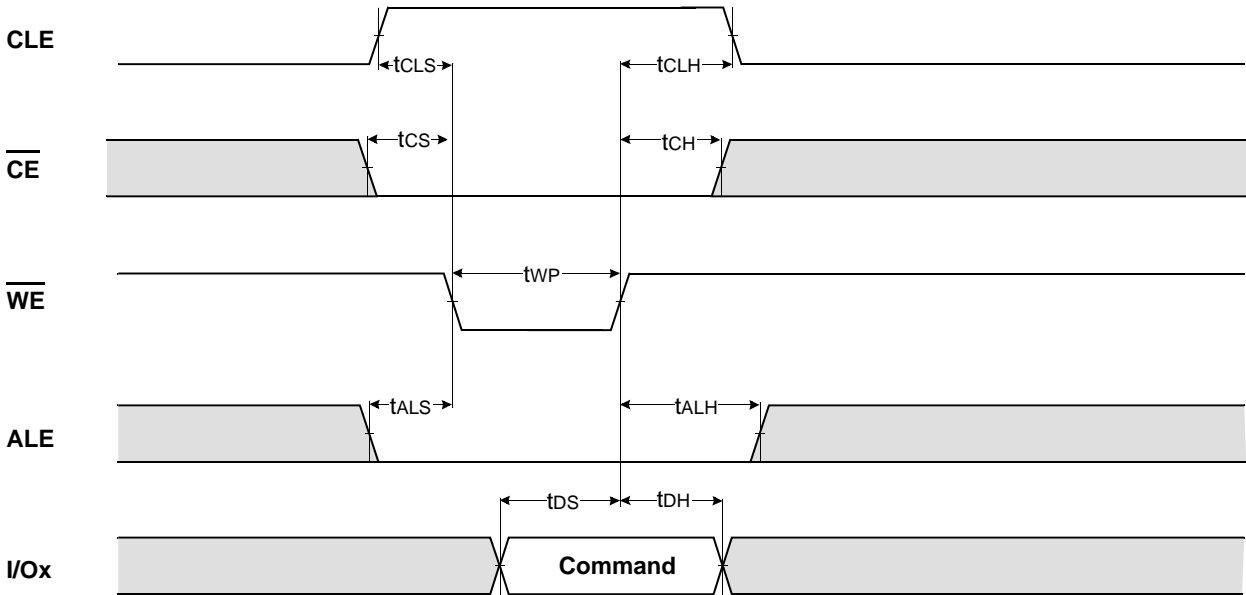

* Address Latch Cycle

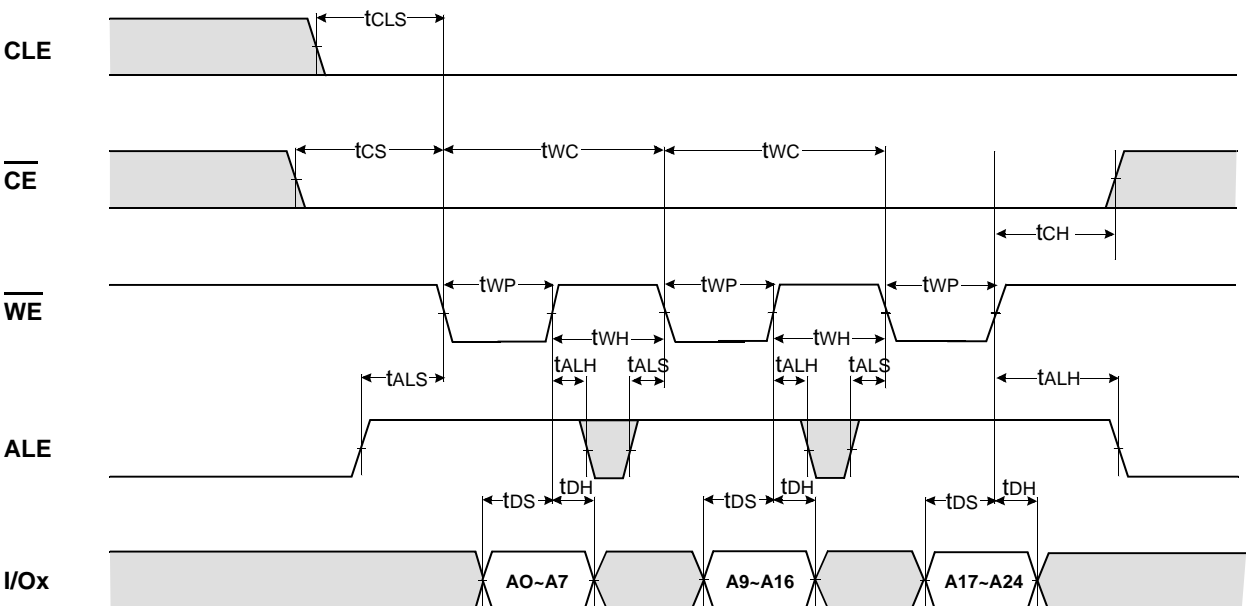

*** Input Data Latch Cycle**

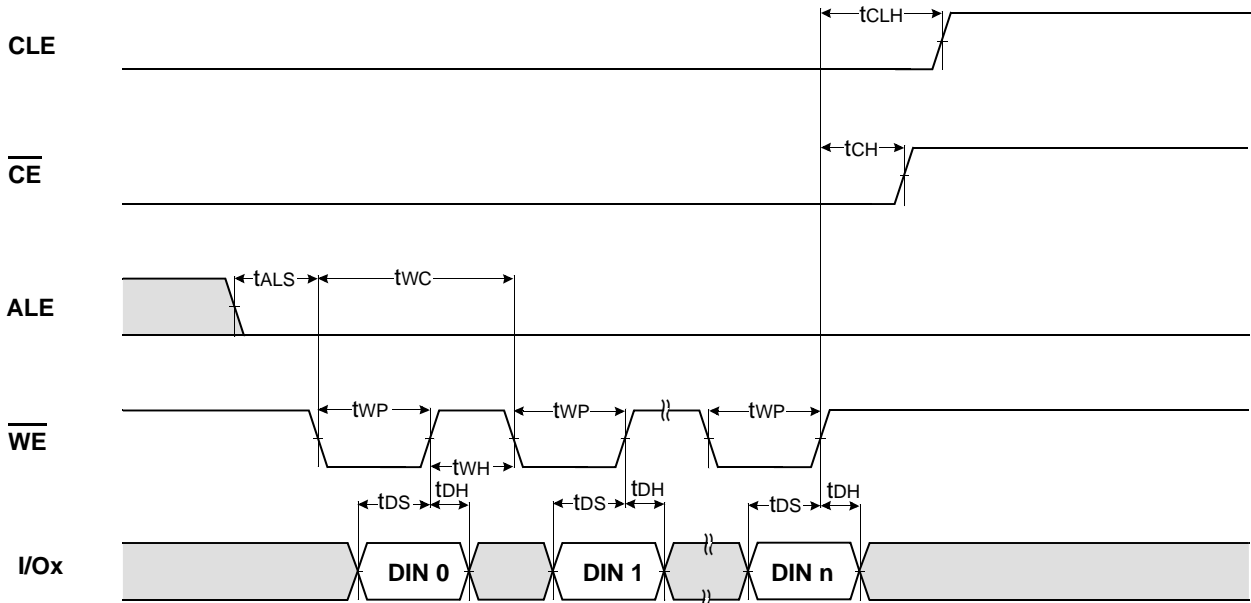

*** Sequential Out Cycle after Read (CLE=L, WE=H, ALE=L)**

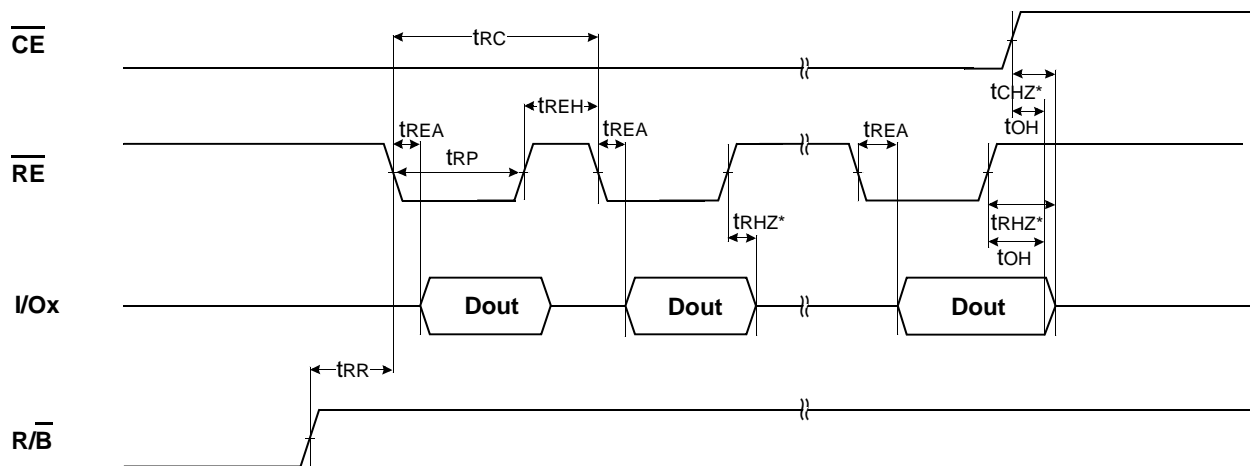

NOTES : Transition is measured $\pm 200\text{mV}$ from steady state voltage with load.
 This parameter is sampled and not 100% tested.

*** Status Read Cycle**

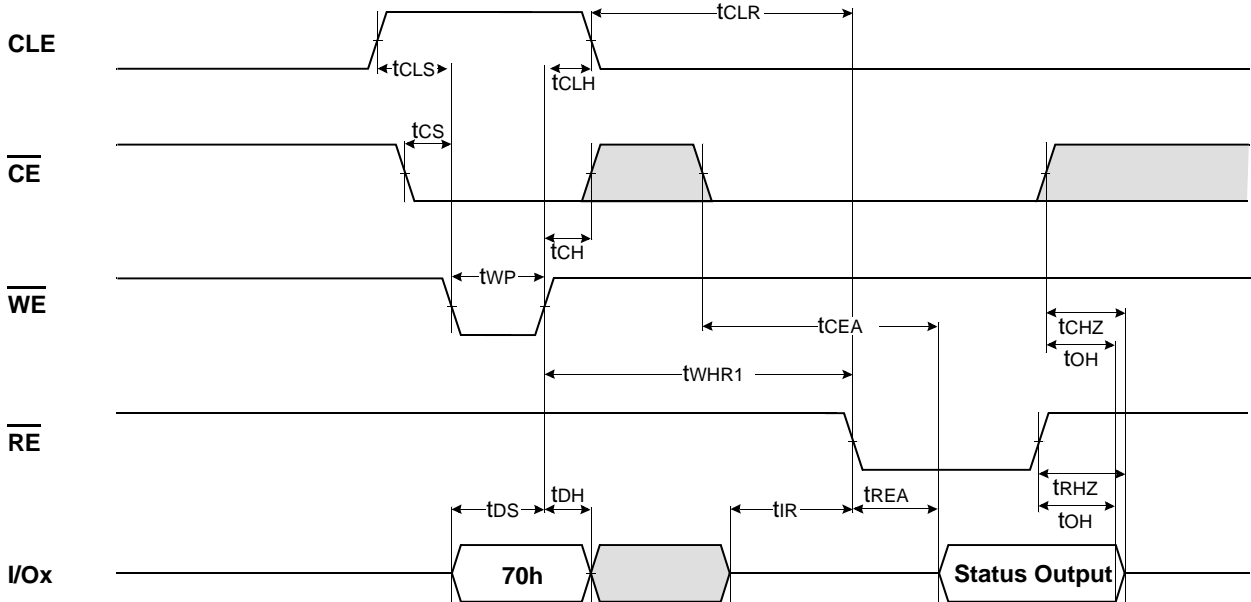

READ1 OPERATION(READ ONE PAGE)

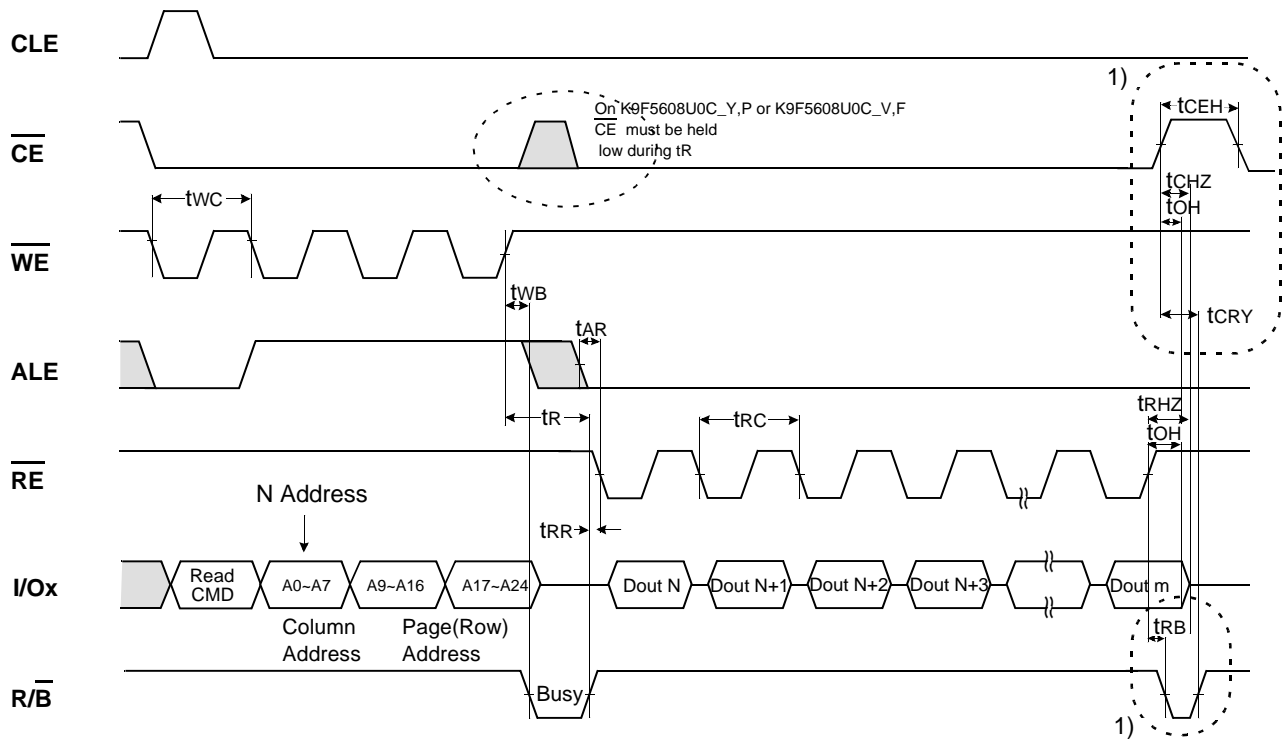

X8 device : m = 528 , Read CMD = 00h or 01h
 X16 device : m = 264 , Read CMD = 00h

NOTES : 1) is only valid on K9F5608U0C_Y,P or K9F5608U0C_V,F

READ1 OPERATION (INTERCEPTED BY \overline{CE})

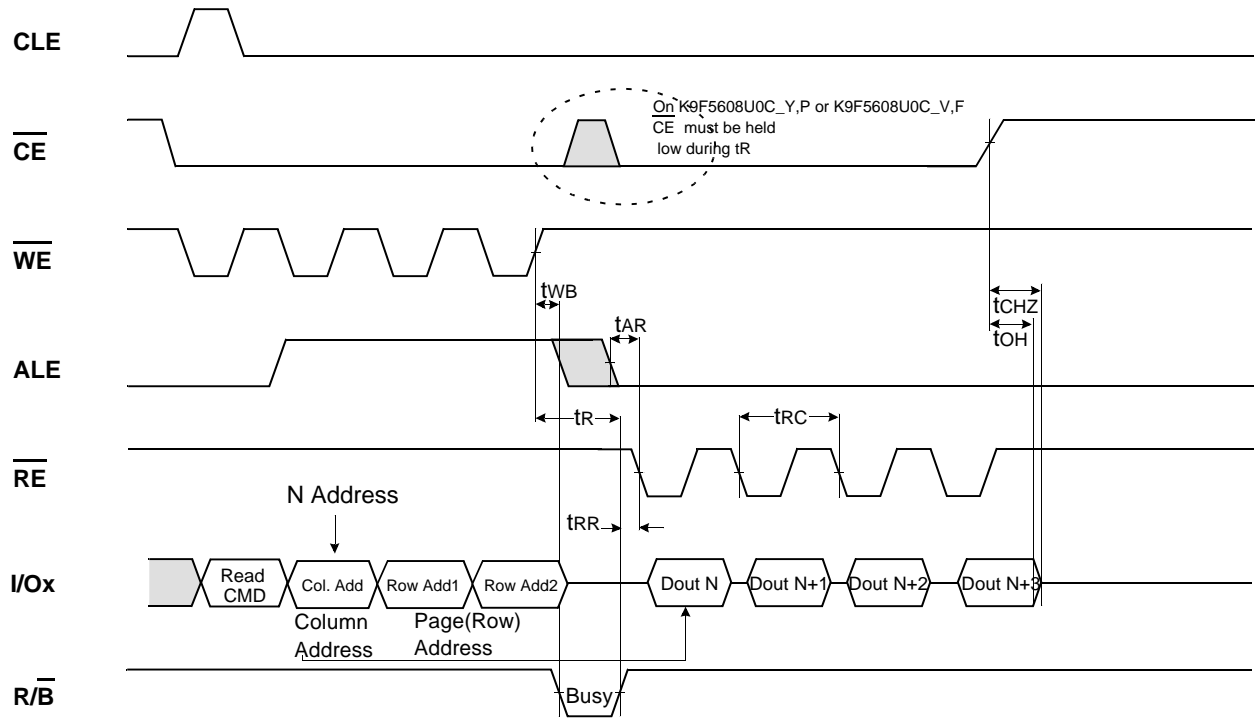

READ2 OPERATION (READ ONE PAGE)

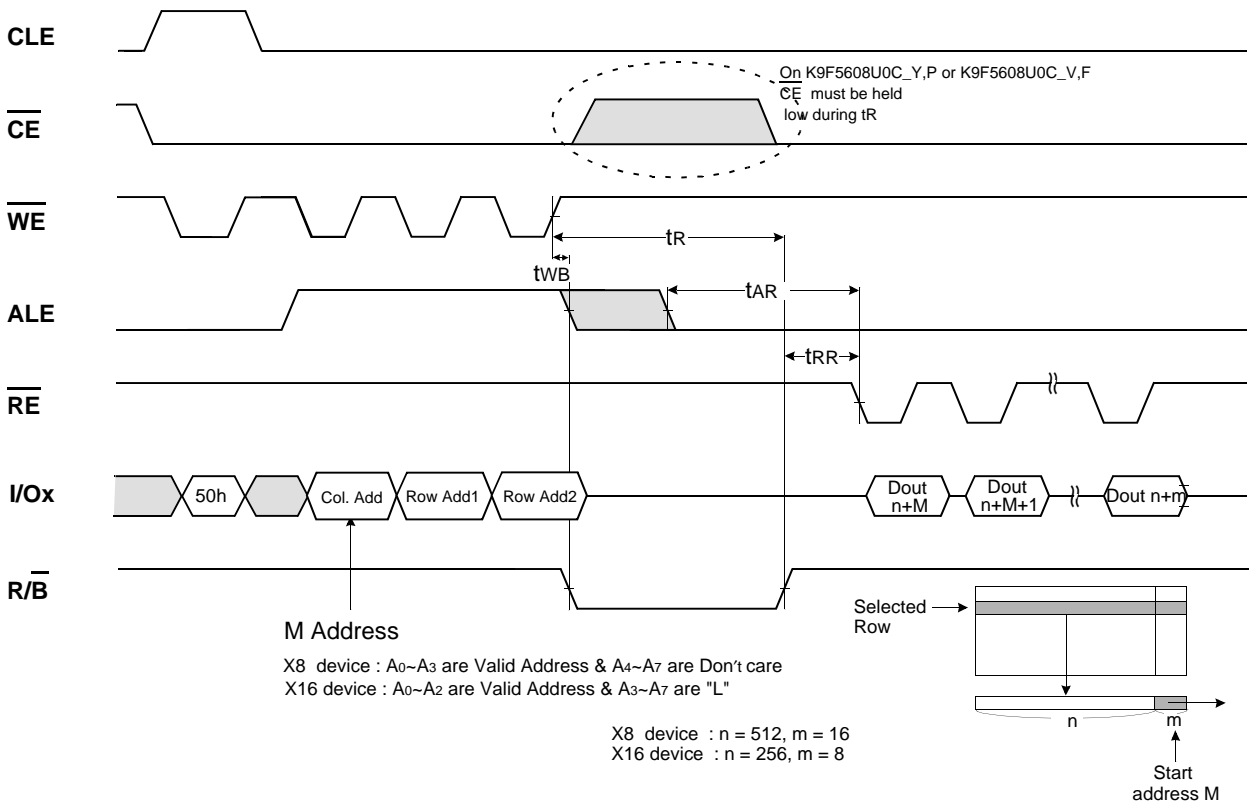

SEQUENTIAL ROW READ OPERATION (only for K9F5608U0C-Y,P or K9F5608U0C-V,F)

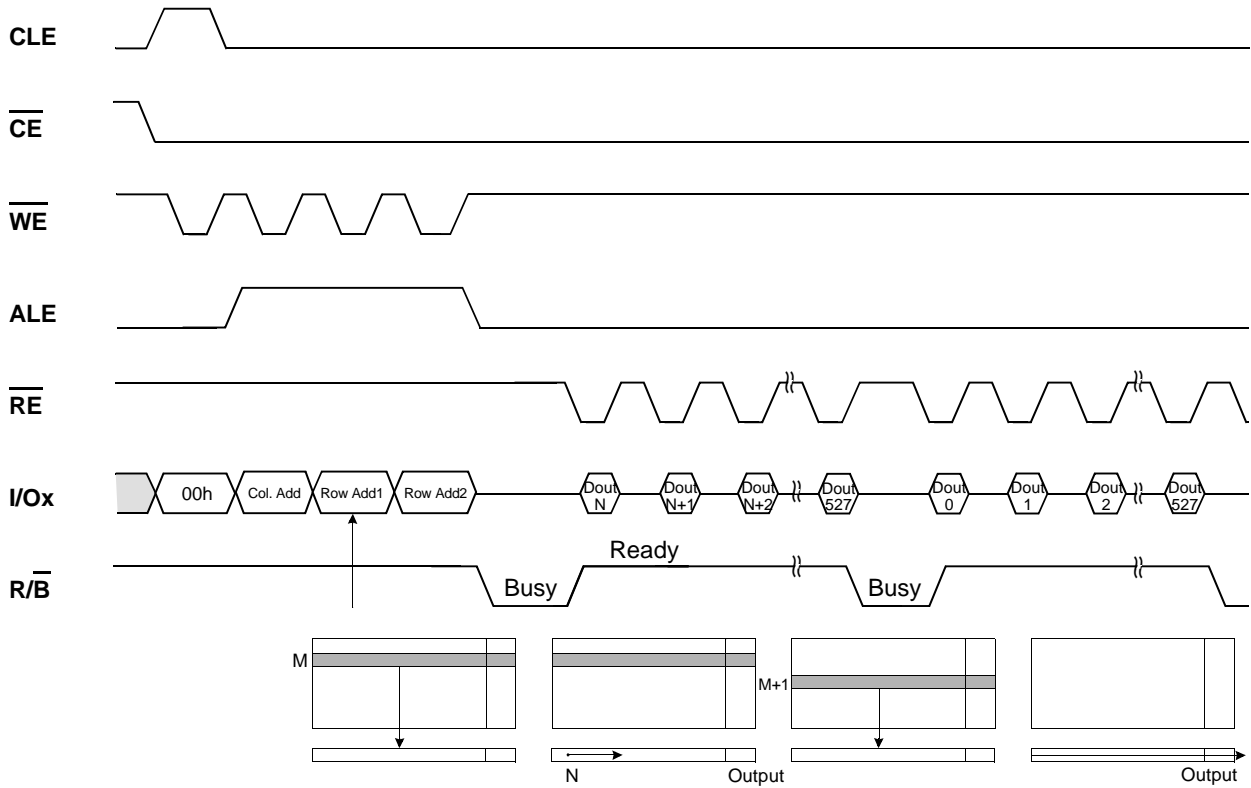

PAGE PROGRAM OPERATION

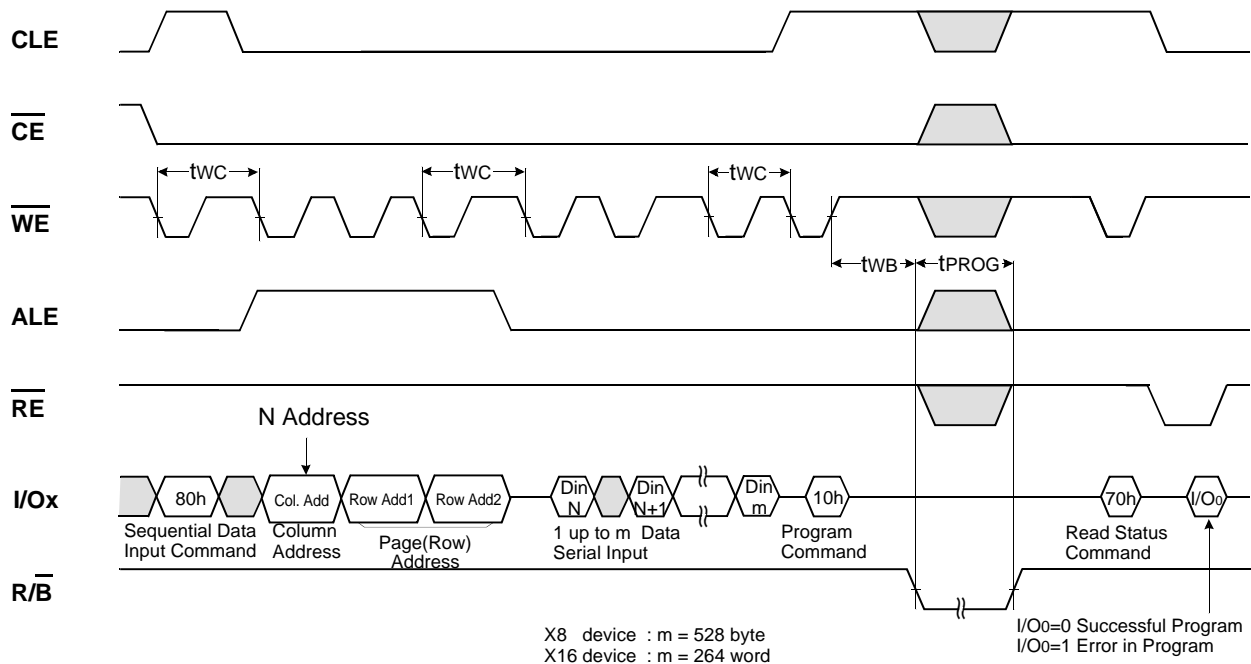

COPY-BACK PROGRAM OPERATION

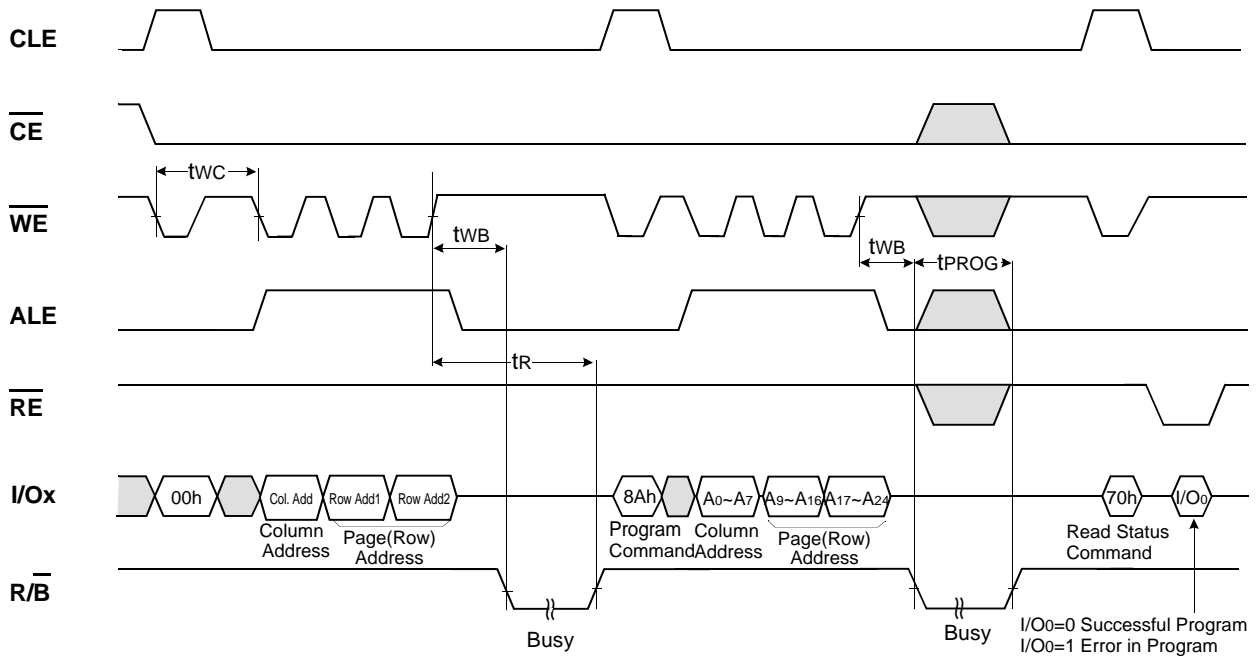

BLOCK ERASE OPERATION (ERASE ONE BLOCK)

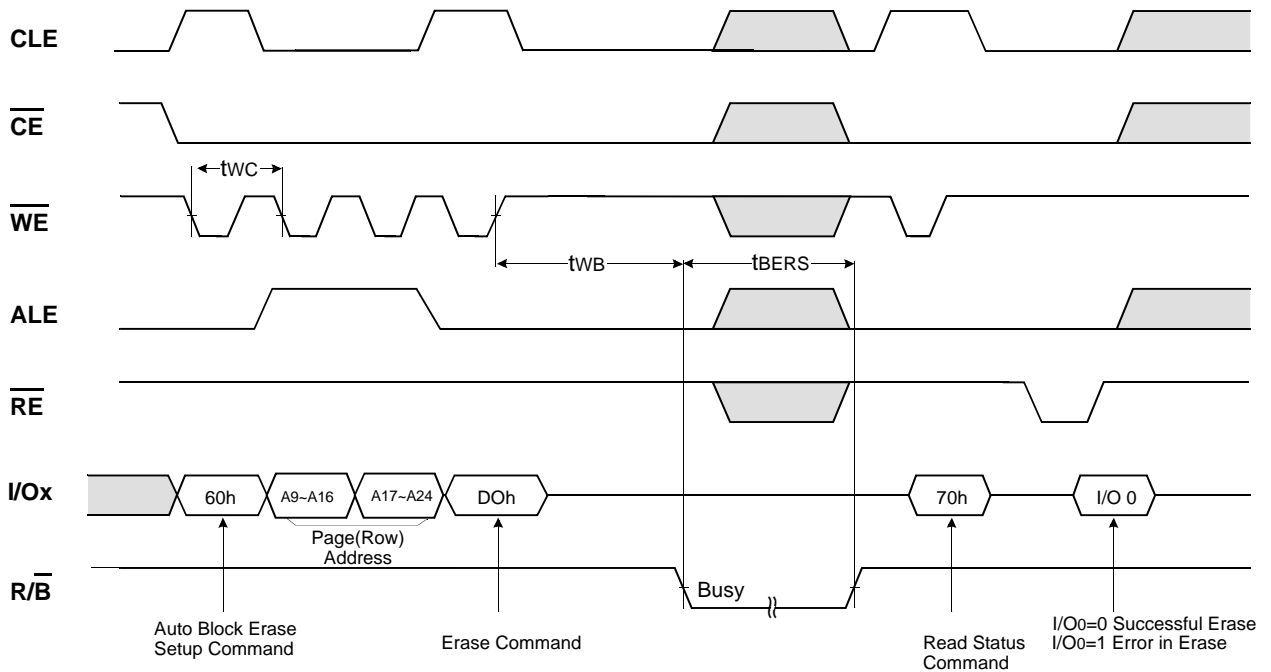

K9F5608U0C-VCB0,VIB0,FCB0,FIB0
 K9F5608Q0C-DCB0,DIB0,HCB0,HIB0
 K9F5608U0C-YCB0,YIB0,PCB0,PIB0
 K9F5608U0C-DCB0,DIB0,HCB0,HIB0

K9F5616Q0C-DCB0,DIB0,HCB0,HIB0
 K9F5616U0C-YCB0,YIB0,PCB0,PIB0
 K9F5616U0C-DCB0,DIB0,HCB0,HIB0

FLASH MEMORY

MANUFACTURE & DEVICE ID READ OPERATION

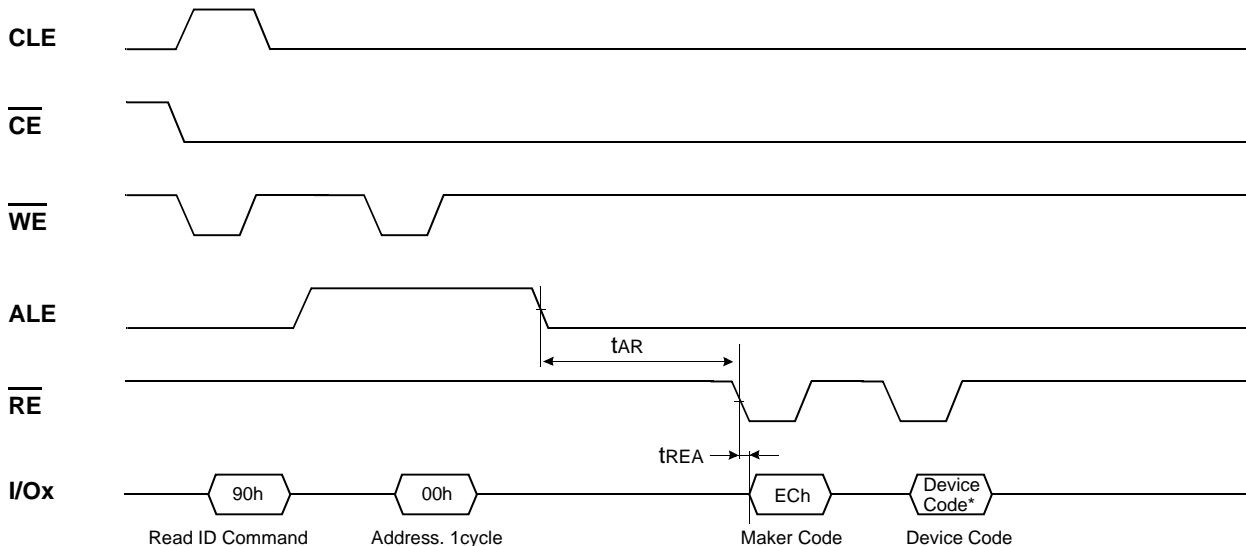

Device	Device Code*
K9F5608Q0C	35h
K9F5608U0C	75h
K9F5616Q0C	XX45h
K9F5616U0C	XX55h

DEVICE OPERATION

PAGE READ

Upon initial device power up, the device defaults to Read1 mode. This operation is also initiated by writing 00h to the command register along with three address cycles. Once the command is latched, it does not need to be written for the following page read operation. Two types of operations are available : random read, serial page read.

The random read mode is enabled when the page address is changed. The 528 bytes(X8 device) or 264 words(X16 device) of data within the selected page are transferred to the data registers in less than 10µs(tR). The system controller can detect the completion of this data transfer(tR) by analyzing the output of R/B pin. Once the data in a page is loaded into the registers, they may be read out in 50ns cycle time by sequentially pulsing RE. High to low transitions of the RE clock output the data starting from the selected column address up to the last column address[column 511/ 527(X8 device) 255 /263(X16 device) depending on the state of GND input pin].

The way the Read1 and Read2 commands work is like a pointer set to either the main area or the spare area. The spare area of 512 ~527 bytes(X8 device) or 256~263 words(X16 device) may be selectively accessed by writing the Read2 command with GND input pin low. Addresses A0-A3(X8 device) or A0-A2(X16 device) set the starting address of the spare area while addresses A4~A7 are ignored in X8 device case or A3-A7 must be "L" in X16 device case. The Read1 command is needed to move the pointer back to the main area. Figures 8,9 show typical sequence and timings for each read operation.

Sequential Row Read is available only on K9F5608U0C_Y,P or K9F5608U0C_V,F :

After the data of last column address is clocked out, the next page is automatically selected for sequential row read. Waiting 10µs again allows reading the selected page. The sequential row read operation is terminated by bringing CE high. Unless the operation is aborted, the page address is automatically incremented for sequential row read as in Read1 operation and spare sixteen bytes of each page may be sequentially read. The Sequential Read 1 and 2 operation is allowed only within a block and after the last page of a block is readout, the sequential read operation must be terminated by bringing CE high. When the page address moves onto the next block, read command and address must be given. Figures 8-1, 9-1 show typical sequence and timings for sequential row read operation.

Figure8. Read1 Operation

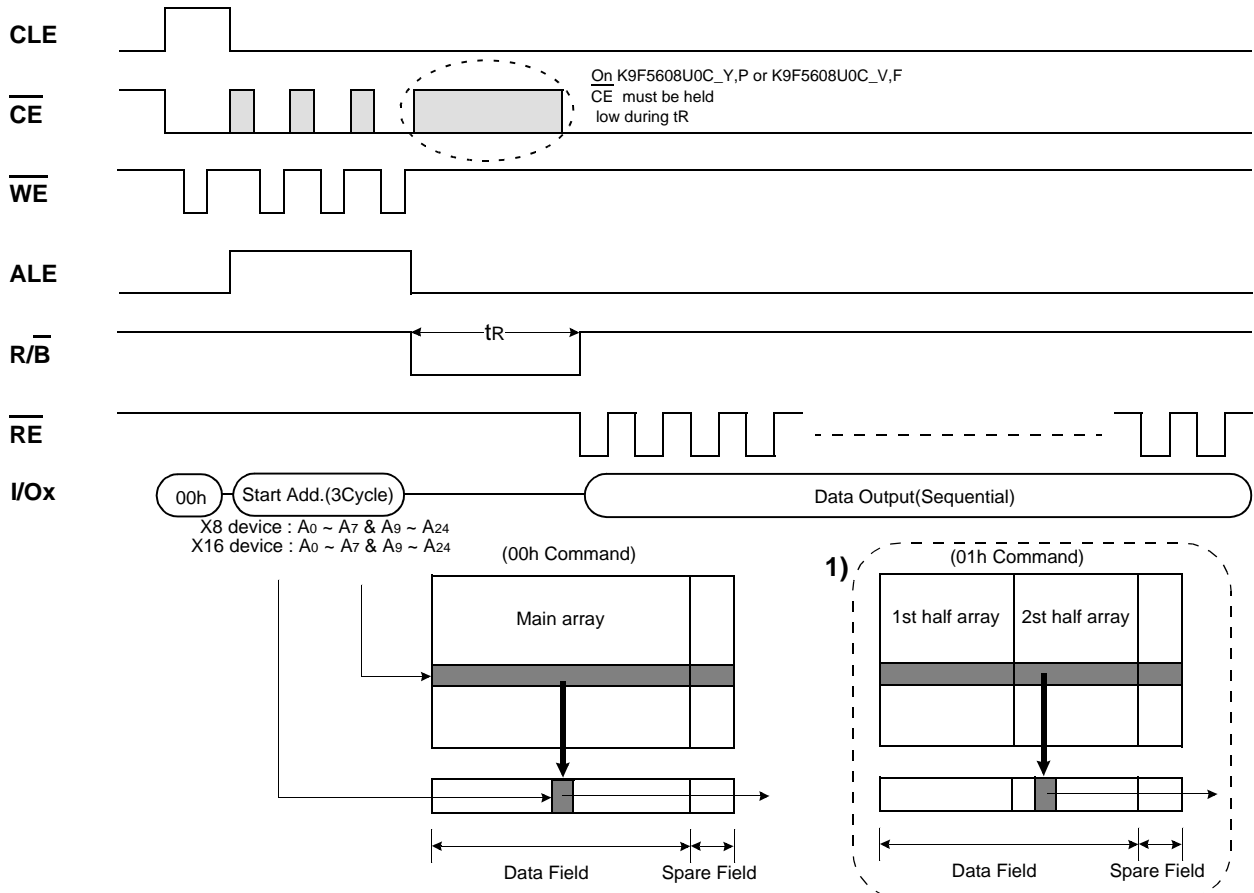

NOTE: 1) After data access on 2nd half array by 01h command, the start pointer is automatically moved to 1st half array (00h) at next cycle. 01h command is only available on X8 device(K9F5608X0C).

Figure 9. Read2 Operation

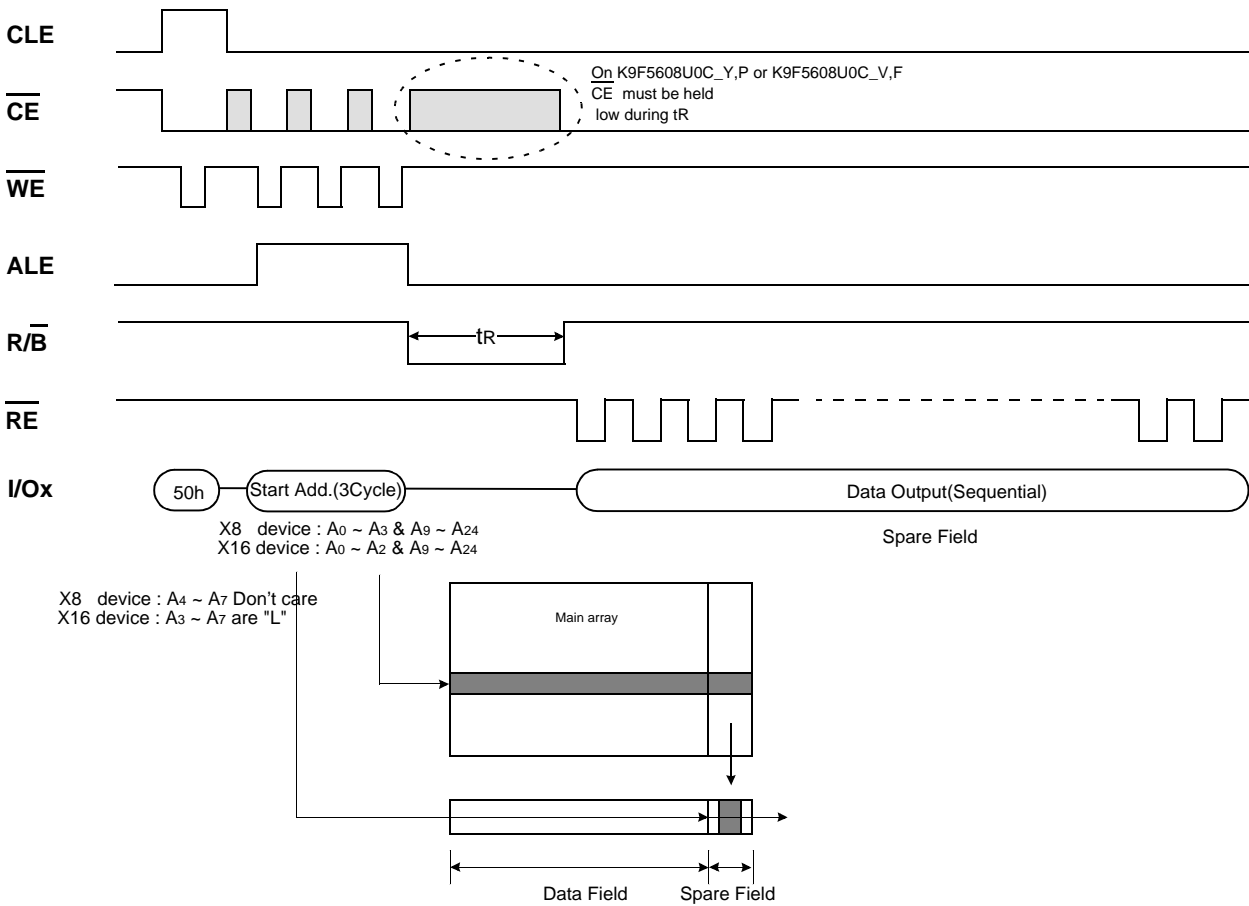
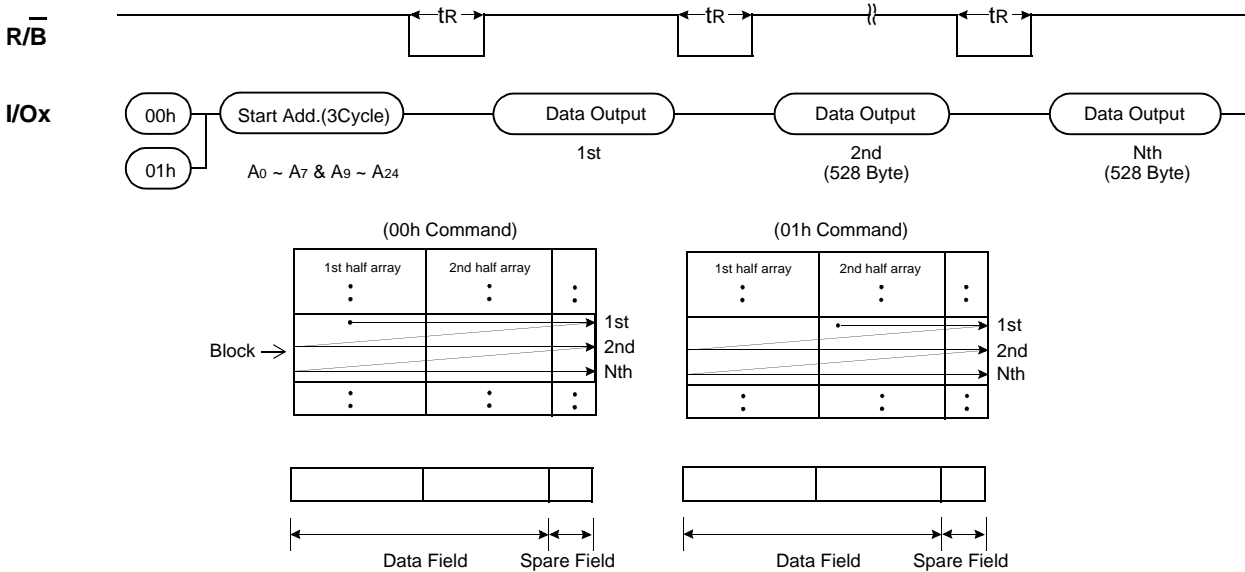

Figure 8-1. Sequential Row Read1 Operation (only for K9F5608U0C-Y,P or K9F5608U0C-V,F)



K9F5608U0C-VCB0,VIB0,FCB0,FIB0
 K9F5608Q0C-DCB0,DIB0,HCBO,HIB0
 K9F5608U0C-YCB0,YIB0,PCB0,PIB0
 K9F5608U0C-DCB0,DIB0,HCBO,HIB0

K9F5616Q0C-DCB0,DIB0,HCBO,HIB0
 K9F5616U0C-YCB0,YIB0,PCB0,PIB0
 K9F5616U0C-DCB0,DIB0,HCBO,HIB0

FLASH MEMORY

Figure 9-1. Sequential Row Read2 Operation (only for K9F5608U0C-Y,P or K9F5608U0C-V,F)

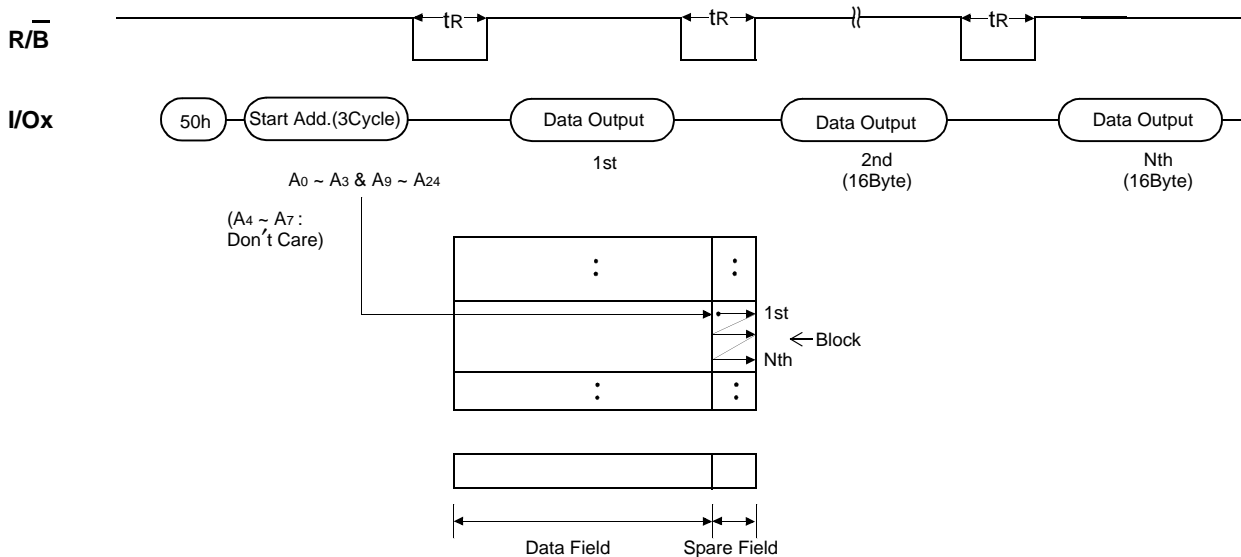

PAGE PROGRAM

The device is programmed basically on a page basis, but it does allow multiple partial page programming of a byte/word or consecutive bytes/words up to 528(X8 device) or 264(X16 device), in a single page program cycle. The number of consecutive partial page programming operation within the same page without an intervening erase operation should not exceed 2 for main array and 3 for spare array. The addressing may be done in any random order in a block. A page program cycle consists of a serial data loading period in which up to 528 bytes(X8 device) or 264 words(X16 device) of data may be loaded into the page register, followed by a non-volatile programming period where the loaded data is programmed into the appropriate cell. About the pointer operation, please refer to the attached technical notes.

The serial data loading period begins by inputting the Serial Data Input command(80h), followed by the three cycle address input and then serial data loading. The words other than those to be programmed do not need to be loaded. The Page Program confirm command(10h) initiates the programming process. Writing 10h alone without previously entering the serial data will not initiate the programming process. The internal write controller automatically executes the algorithms and timings necessary for program and verify, thereby freeing the system controller for other tasks. Once the program process starts, the Read Status Register command may be entered, with RE and CE low, to read the status register. The system controller can detect the completion of a program cycle by monitoring the R/B output, or the Status bit(I/O 6) of the Status Register. Only the Read Status command and Reset command are valid while programming is in progress. When the Page Program is complete, the Write Status Bit(I/O 0) may be checked(Figure 10). The internal write verify detects only errors for "1"s that are not successfully programmed to "0"s. The command register remains in Read Status command mode until another valid command is written to the command register.

Figure 10. Program Operation

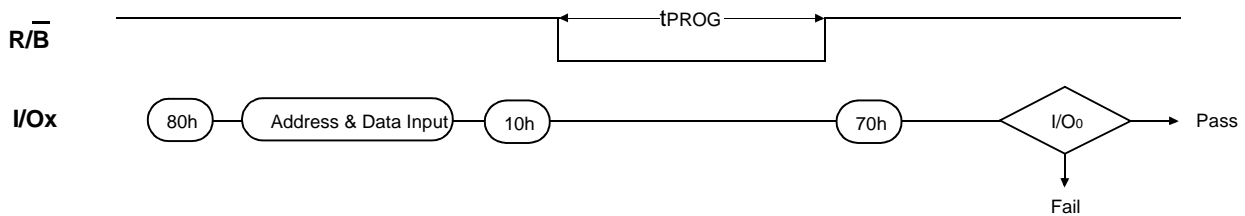

COPY-BACK PROGRAM

The copy-back program is configured to quickly and efficiently rewrite data stored in one page within the array to another page within the same array without utilizing an external memory. Since the time-consuming sequently-reading and its re-loading cycles are removed, the system performance is improved. The benefit is especially obvious when a portion of a block is updated and the rest of the block also need to be copied to the newly assigned free block. The operation for performing a copy-back is a sequential execution of page-read without burst-reading cycle and copying-program with the address of destination page. A normal read operation with "00h" command with the address of the source page moves the whole 528bytes/264words(X8 device:528bytes, X16 device:264words) data into the internal buffer. As soon as the Flash returns to Ready state, copy-back programming command "8Ah" may be given with three address cycles of target page followed. The data stored in the internal buffer is then programmed directly into the memory cells of the destination page. Once the Copy-Back Program is finished, any additional partial page programming into the copied pages is prohibited before erase. Since the memory array is internally partitioned into two different planes, copy-back program is allowed only within the same memory plane. Thus, A14, the plane address, of source and destination page address must be the same.

Figure 11. Copy-Back Program Operation

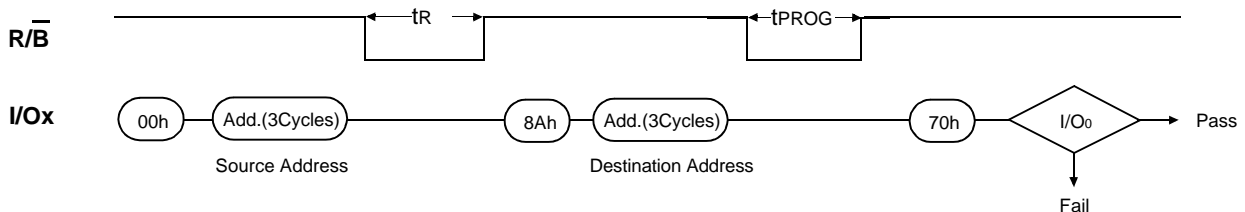

BLOCK ERASE

The Erase operation is done on a block basis. Block address loading is accomplished in two cycles initiated by an Erase Setup command(60h). Only address A14 to A24 is valid while A9 to A13 is ignored. The Erase Confirm command(D0h) following the block address loading initiates the internal erasing process. This two-step sequence of setup followed by execution command ensures that memory contents are not accidentally erased due to external noise conditions.

At the rising edge of WE after the erase confirm command input, the internal write controller handles erase and erase-verify. When the erase operation is completed, the Write Status Bit(I/O 0) may be checked. Figure 12 details the sequence.

Figure 12. Block Erase Operation

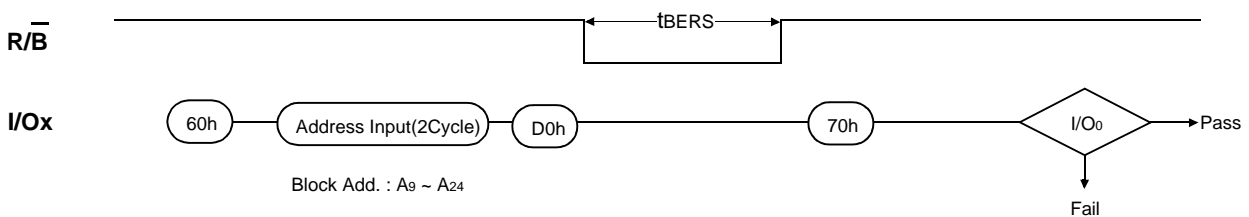

READ STATUS

The device contains a Status Register which may be read to find out whether program or erase operation is completed, and whether the program or erase operation is completed successfully. After writing 70h command to the command register, a read cycle outputs the content of the Status Register to the I/O pins on the falling edge of CE or RE, whichever occurs last. This two line control allows the system to poll the progress of each device in multiple memory connections even when R/B pins are common-wired. RE or CE does not need to be toggled for updated status. Refer to table 4 for specific Status Register definitions. The command register remains in Status Read mode until further commands are issued to it. Therefore, if the status register is read during a random read cycle, a read command(00h or 50h) should be given before sequential page read cycle.

Table4. Read Status Register Definition

I/O #	Status	Definition
I/O 0	Program / Erase	"0" : Successful Program / Erase
		"1" : Error in Program / Erase
I/O 1	Reserved for Future Use	"0"
I/O 2		"0"
I/O 3		"0"
I/O 4		"0"
I/O 5		"0"
I/O 6	Device Operation	"0" : Busy "1" : Ready
I/O 7	Write Protect	"0" : Protected "1" : Not Protected
I/O 8~15	Not use	Don't care

READ ID

The device contains a product identification mode, initiated by writing 90h to the command register, followed by an address input of 00h. Two read cycles sequentially output the manufacture code(ECh), and the device code respectively. The command register remains in Read ID mode until further commands are issued to it. Figure 13 shows the operation sequence.

Figure 13. Read ID Operation

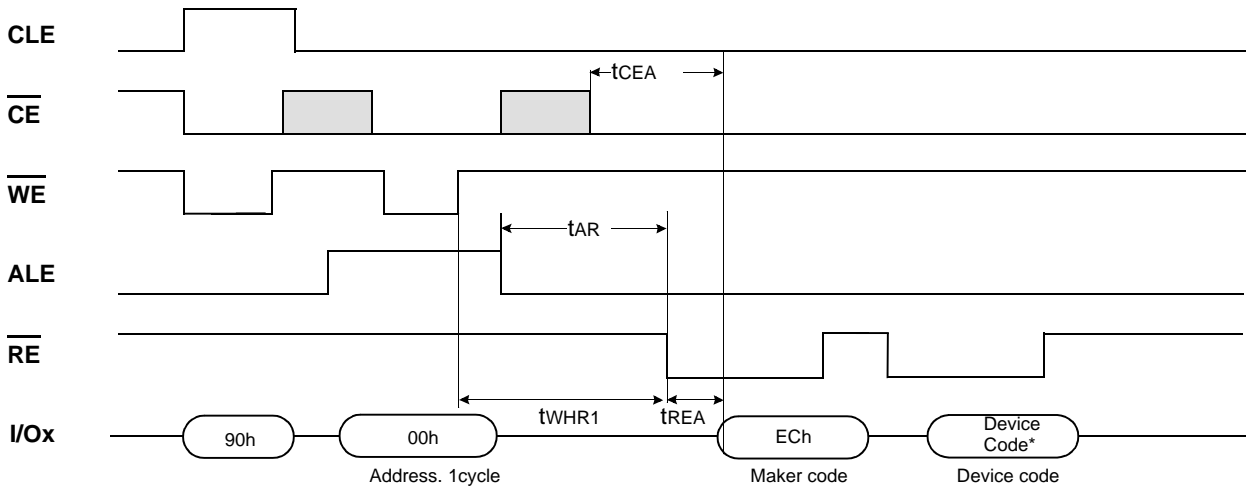

Device	Device Code*
K9F5608Q0C	35h
K9F5608U0C	75h
K9F5616Q0C	45h
K9F5616U0C	55h

RESET

The device offers a reset feature, executed by writing FFh to the command register. When the device is in Busy state during random read, program or erase mode, the reset operation will abort these operations. The contents of memory cells being altered are no longer valid, as the data will be partially programmed or erased. The command register is cleared to wait for the next command, and the Status Register is cleared to value C0h when WP is high. Refer to table 5 for device status after reset operation. If the device is already in reset state a new reset command will not be accepted by the command register. The R/B pin transitions to low for tRST after the Reset command is written. Refer to Figure 14 below.

Figure 14. RESET Operation

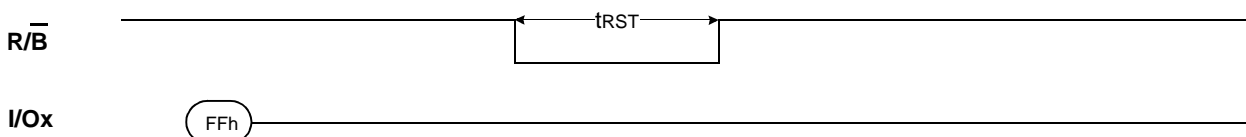

Table 5. Device Status

	After Power-up	After Reset
Operation Mode	Read 1	Waiting for next command

> In high state of LOCKPRE pin, Block lock mode and Power on Auto read are enabled, otherwise it is regarded as NAND Flash without LOCKPRE pin.

Block Lock Mode

Block Lock mode is enabled while LOCKPRE pin state is high, which is to offer protection features for NAND Flash data. The Block Lock mode is divided into Unlock, Lock, Lock-tight operation. Consecutive blocks protects data by allowing those blocks to be locked or lock-tighten with no latency. This block lock scheme offers two levels of protection. The first allows software control(command input method) of block locking that is useful for frequently changed data blocks, while the second requires hardware control(WP low pulse input method) before locking can be changed that is useful for protecting infrequently changed code blocks.

The followings summarized the locking functionality.

- All blocks are in a locked state on power-up. Unlock sequence can unlock the locked blocks.
- The Lock-tight command locks blocks and prevents from being unlocked.
- And Lock-tight state can be returned to lock state only by Hardware control(WP low pulse input).

1. Block lock operation

1) Lock

- Command Sequence: Lock block Command(2Ah)
- All blocks default to locked by power-up and Hardware control(WP low pulse input)
- Partial block lock is not available; Lock block operation is based on all block unit
- Unlocked blocks can be locked by using the Lock block command, and a lock block's status can be changed to unlock or lock-tight using the appropriate commands

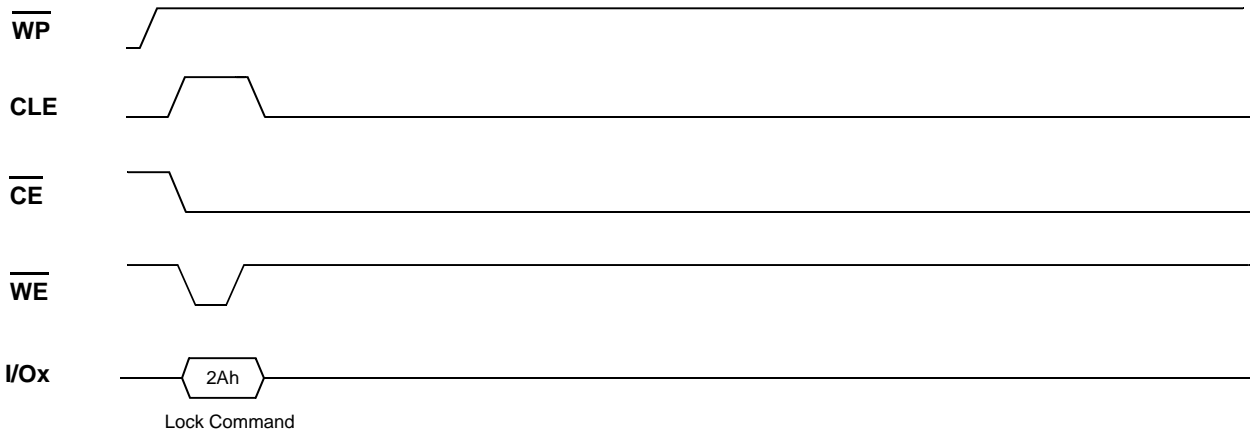

2) Unlock

- Command Sequence: Unlock block Command(23h) + Start block address + Command(24h) + End block address
- Unlocked blocks can be programmed or erased.
- An unlocked block's status can be changed to the locked or lock-tighten state using the appropriate commands.
- Only one consecutive area can be released to unlock state from lock state; Unlocking multi area is not available.
- Start block address must be nearer to the logical LSB(Least Significant Bit) than End block address.
- One block is selected for unlocking block when Start block address is same as End block address.

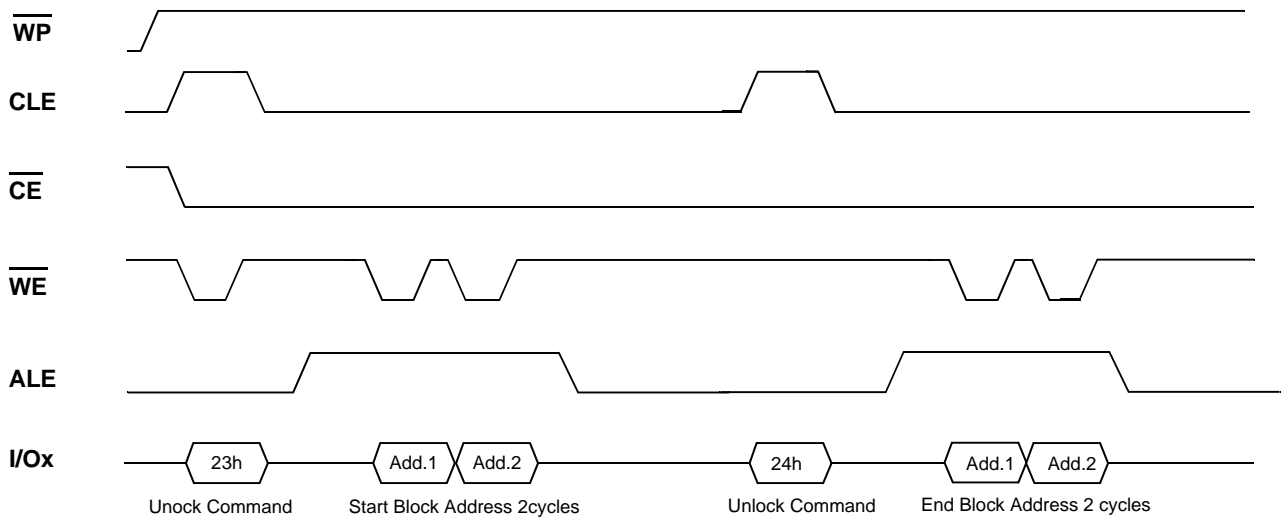

3) Lock-tight

- Command Sequence: Lock-tight block Command(2Ch)
- Lock-tighten blocks offer the user an additional level of write protection beyond that of a regular lock block. A block that is lock-tighten can't have its state changed by software control, only by hardware control(WP low pulse input); Unlocking multi area is not available
- Only locked blocks can be lock-tighten by lock-tight command.



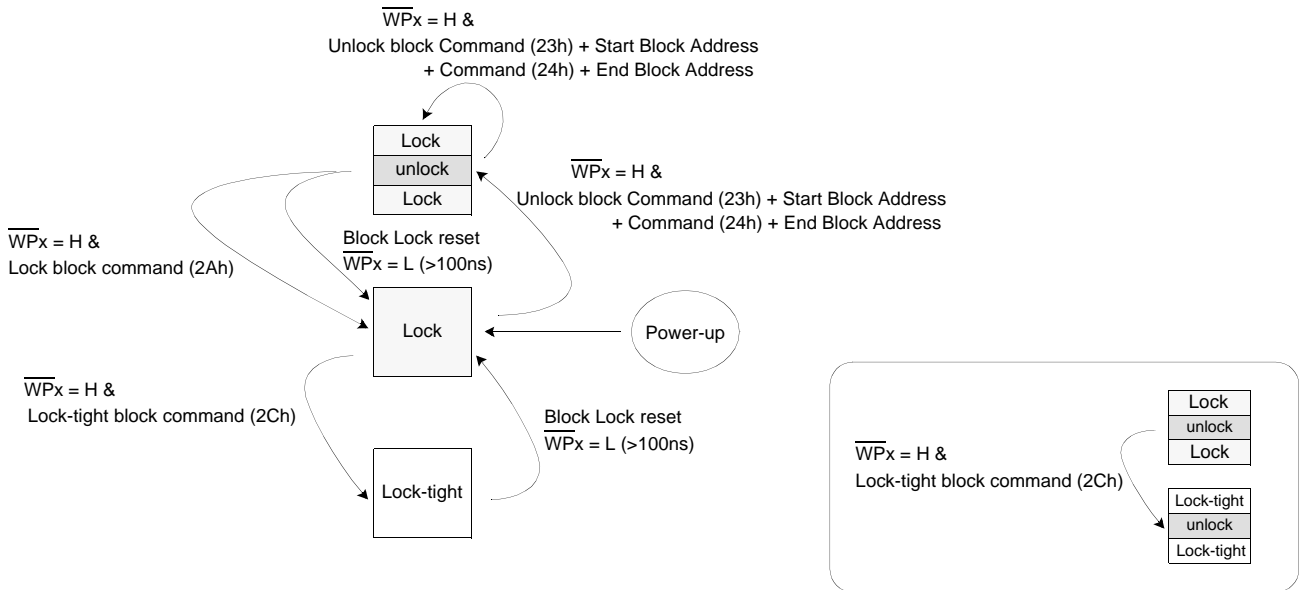
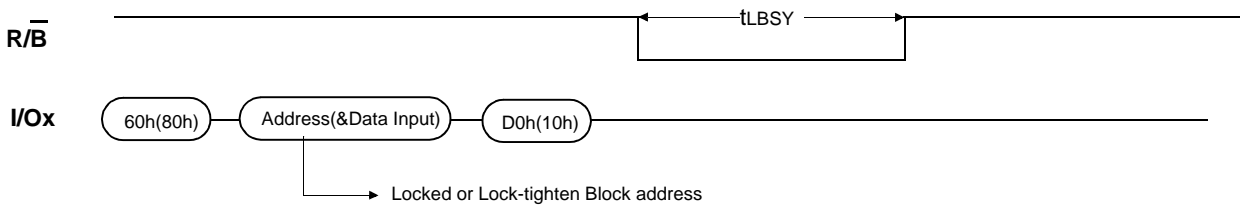

Figure 15. State diagram of Block Lock

Program/Erase OPERATION(In Locked or Lock-tighten Block)



On the program or erase operation in Locked or Lock-tighten block, Busy state holds 1~10ms(tLBSY)

2. Block Lock Status Read

Block Lock Status can be read on a block basis, which may be read to find out whether designated block is available to be programmed or erased. After writing 7Ah command to the command register, and block address to be checked, a read cycle outputs the content of the Block Lock Status Register to the I/O pins on the falling edge of CE or RE, whichever occurs last. This two line control allows the system to poll the progress of each device in multiple memory connections even when R/B pins are common-wired. RE or CE does not need to be toggled for updated status. Block Lock Status Read is prohibited while the device is busy state. Refer to table 6 for specific Status Register definitions. The command register remains in Block Lock Status Read mode until further commands are issued to it. **In high state of LOCKPRE pin, write protection status can be checked by Block Lock Status Read(7Ah) while in low state by Status Read(70h).**

	IO7~IO3	IO2(Unlock)	IO1(Lock)	IO0(Lock-tight)
Read 1) block case	X	0	1	0
Read 2) block case	X	1	1	0
Read 3) block case	X	0	0	1
Read 4) block case	X	1	0	1

(1)Lock	(3)Lock-tight	(1)Lock	(2)Unlock	(3)Lock-tight
(2)unlock	(4)unlock			
(1)Lock	(3)Lock-tight			

Table6. Block Lock Status Register definitions

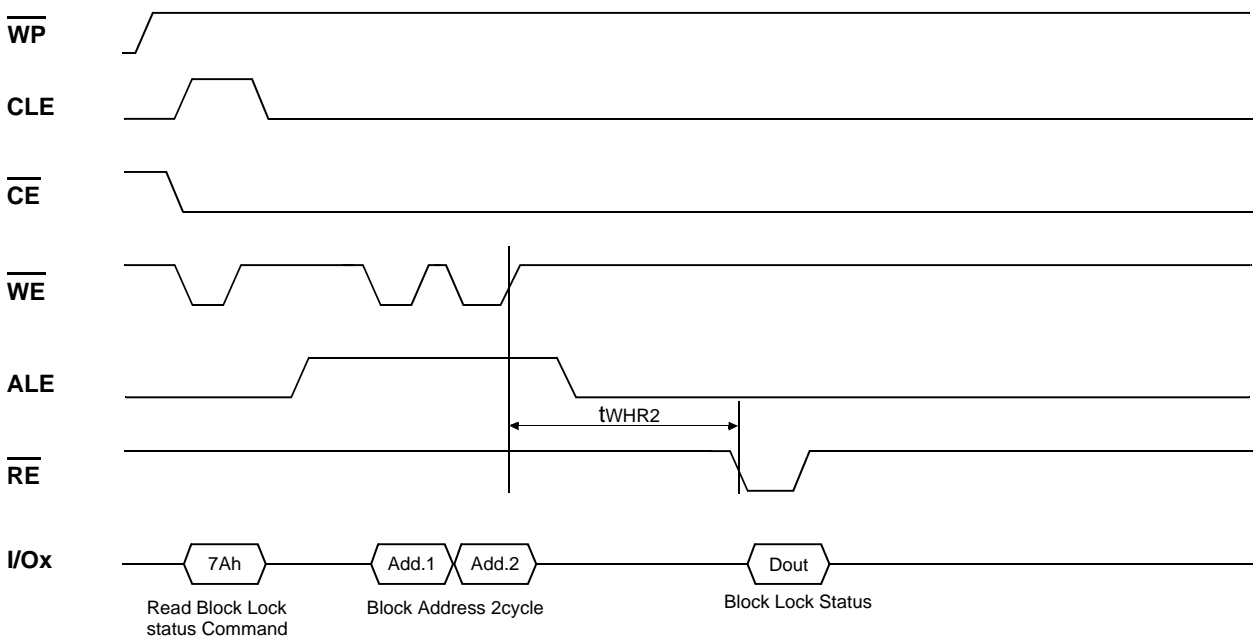

Power-On Auto-Read

The device is designed to offer automatic reading of the first page without command and address input sequence during power-on. An internal voltage detector enables auto-page read functions when Vcc reaches about 1.8V. LOCKPRE pin controls activation of auto- page read function. Auto- page read function is enabled only when LOCKPRE pin is logic high state. Serial access may be done after power-on without latency. Power-On Auto Read mode is available only on 3.3V device(K9F56XXU0C).

Figure 16. Power-On Auto-Read (3.3V device only)

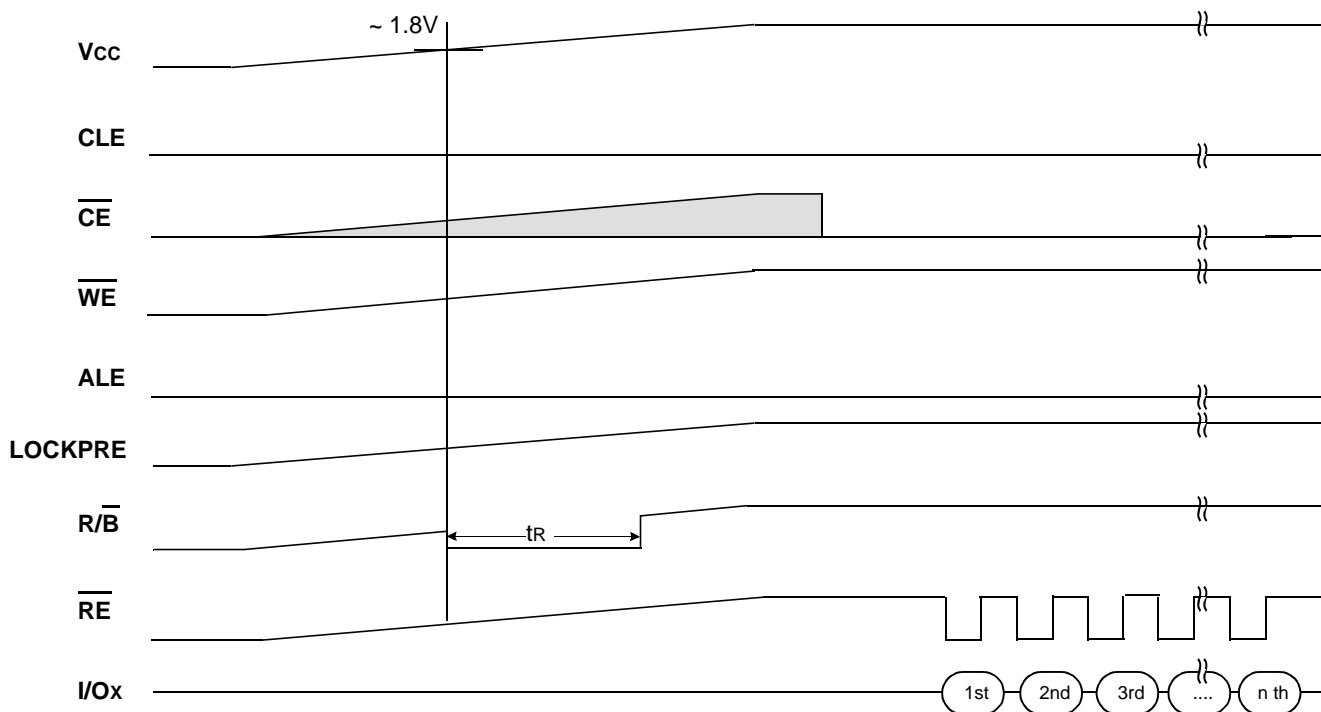

READY/BUSY

The device has a $\overline{R/B}$ output that provides a hardware method of indicating the completion of a page program, erase and random read completion. The $\overline{R/B}$ pin is normally high but transitions to low after program or erase command is written to the command register or random read is started after address loading. It returns to high when the internal controller has finished the operation. The pin is an open-drain driver thereby allowing two or more $\overline{R/B}$ outputs to be Or-tied. Because pull-up resistor value is related to $t_r(\overline{R/B})$ and current drain during busy(i_{busy}), an appropriate value can be obtained with the following reference chart(Fig 17). Its value can be determined by the following guidance.

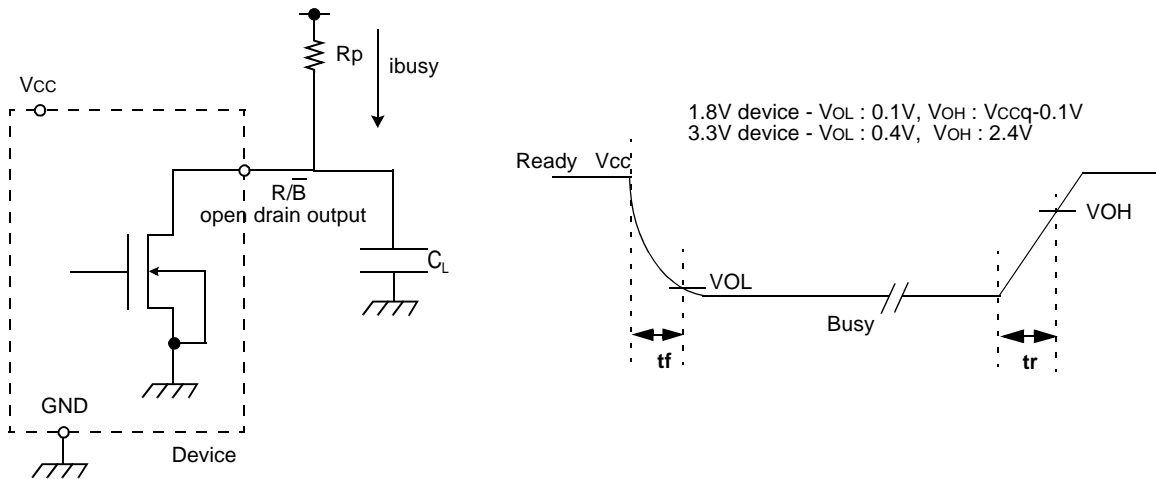
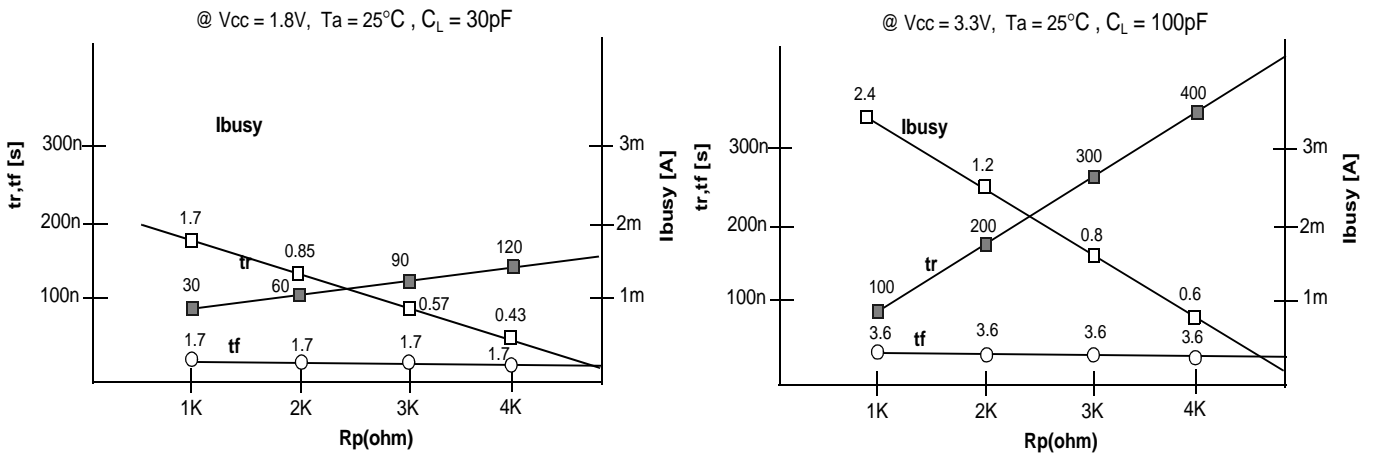

Fig 17 Rp vs tr ,tf & Rp vs i_{busy}



Rp value guidance

$$R_{p(\min, 1.8V \text{ part})} = \frac{V_{cc(\text{Max.})} - V_{oL(\text{Max.})}}{I_{oL} + \sum I_L} = \frac{1.85V}{3mA + \sum I_L}$$

$$R_{p(\min, 3.3V \text{ part})} = \frac{V_{cc(\text{Max.})} - V_{oL(\text{Max.})}}{I_{oL} + \sum I_L} = \frac{3.2V}{8mA + \sum I_L}$$

where I_L is the sum of the input currents of all devices tied to the $\overline{R/B}$ pin.

$R_{p(\max)}$ is determined by maximum permissible limit of t_r

Data Protection & Power up sequence

The device is designed to offer protection from any involuntary program/erase during power-transitions. An internal voltage detector disables all functions whenever Vcc is below about 1.1V(1.8V device) or 2V(3.3V device). \overline{WP} pin provides hardware protection and is recommended to be kept at V_L during power-up and power-down and recovery time of minimum 10 μ s is required before internal circuit gets ready for any command sequences as shown in Figure 18. The two step command sequence for program/erase provides additional software protection.

Figure 18. AC Waveforms for Power Transition

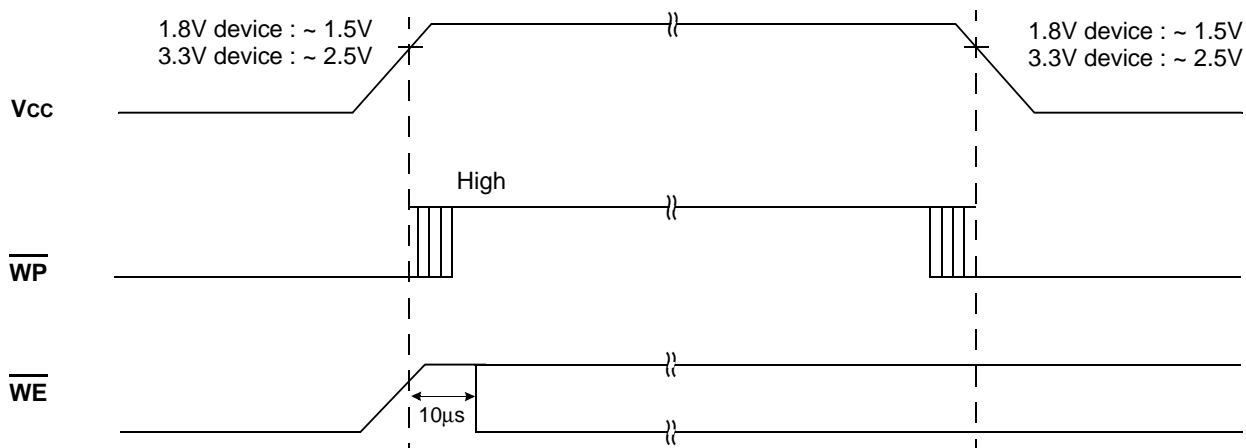

This datasheet has been downloaded from:

www.DatasheetCatalog.com

Datasheets for electronic components.



LittleDiode supplies new, hard to find or obsolete electronic components and semiconductors all over the world.

With over two million different components listed you are sure to find the part you need.

Feel free to visit us today at our online store:

LittleDiode.com

Looking forward to providing you with the best possible service.