

AN7299S

Antenna diversity IC for car TV

■ Overview

The AN7299S is an antenna diversity IC for car TV. A noise detection circuit and an antenna changeover circuit are integrated on one chip.

■ Features

- Built-in vertical and horizontal synchronizing circuit
- Built-in antenna fixing function
- It outputs a composite synchronous signal

■ Applications

- Car TVs

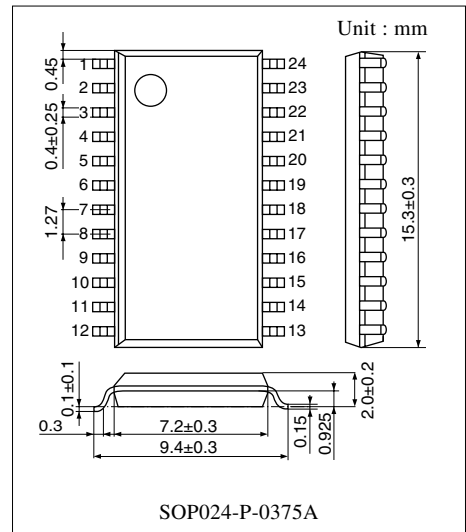

Note) The package of this product will be changed to lead-free type (SOP024-P-0375C). See the new package dimensions section later of this datasheet.

■ Block Diagram

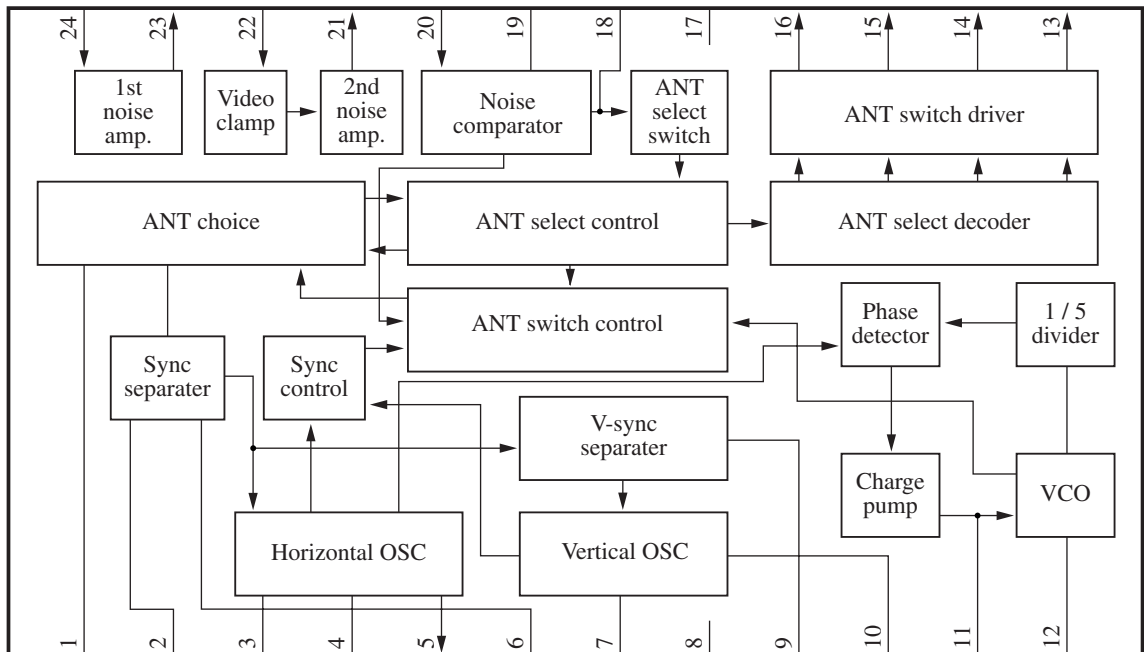

■ Pin Descriptions

Pin No.	Description	Pin No.	Description
1	Antenna selection level-hold capacitor	12	VCO oscillation time-constant setting
2	Sync separation video signal input	13	Antenna selection output 4
3	Horizontal synchronizing signal AFC output	14	Antenna selection output 3
4	Horizontal synchronizing signal oscillation time constant setting	15	Antenna selection output 2
		16	Antenna selection output 1
5	Horizontal synchronizing signal output	17	Power supply
6	Composite synchronizing signal output	18	Noise comparator level setting /Antenna fixing
7	Vertical synchronizing signal output		
8	GND	19	Noise level hold capacitor
9	Vertical synchronizing signal separation time constant setting	20	Noise comparator input
		21	2nd noise amplifier output
10	Vertical synchronizing signal oscillation time constant setting	22	Video clamp input
		23	1st noise amplifier output
11	Charge pump integral time-constant setting	24	Video signal input

■ Absolute Maximum Ratings

Parameter	Symbol	Rating	Unit
Supply voltage	V_{CC}	5.5	V
Supply current	I_{CC}	25	mA
Power dissipation *2	P_D	180	mW
Operating ambient temperature *1	T_{opr}	-35 to +85	°C
Storage temperature *1	T_{stg}	-55 to +125	°C

Note) *1 : All items are at $T_a = 25^\circ\text{C}$, except for the operating ambient temperature and storage temperature.

*2 : $T_a = 85^\circ\text{C}$

■ Recommended Operating Range

Parameter	Symbol	Range	Unit
Supply voltage	V_{CC}	4.5 to 5.5	V

■ Electrical Characteristics at $V_{CC} = 5\text{ V}$, $T_a = 25^\circ\text{C}$

Parameter	Symbol	Conditions	Min	Typ	Max	Unit
Quiescent current without load	I_{SCC}	—	8.5	11.9	17.7	mA
1st amplifier voltage gain	A_{N1}	$V_{IN} = 10\text{ mV}_{PP}$, $f = 10\text{ kHz}$	15.3	17.0	18.2	dB
1st amplifier input clamp voltage	V_{CL1}	Pin 24 DC voltage	1.87	2.00	2.15	V
1st amplifier output bias voltage	V_{NOB1}	Pin 23 DC voltage	2.11	3.07	3.86	V
2nd amplifier voltage gain	A_{N2}	$V_{IN} = 10\text{ mV}[p-p]$, $f = 10\text{ kHz}$, at 2nd amp. active	16.3	17.5	18.5	dB
2nd amplifier input clamp voltage	V_{CL2}	Pin 22 DC voltage at 2nd amp. active	1.96	2.11	2.29	V
2nd amplifier output bias voltage	V_{NOB2}	Pin 21 DC voltage at 2nd amp. active	0.78	1.51	2.10	V
Noise hold input bias current	I_{NHB}	Pin 19 DC current	40.0	110.0	240.0	nA
Noise comparator input bias current	I_{NCB}	Pin 20 DC current	200.0	426.0	820.0	nA
Noise level setting input bias current	I_{NRB}	Pin 18 DC current	350.0	548.0	950.0	nA
Antenna input amplifier voltage gain	A_C	$V_{IN} = 50\text{ mV}[p-p]$, $f = 10\text{ kHz}$, at input amp. active	4.5	5.5	6.4	dB
Level hold output bias voltage	V_{LOB}	Pin 1 DC voltage at input amp. active	0.94	1.43	1.91	V
Level hold output bias current	I_{LOB}	Pin 1 DC voltage at input amp. non-active	20.0	56.4	100.0	nA
Sync separation input clamp voltage	V_{SCL}	Pin 2 DC voltage	2.92	3.13	3.32	V
Sync separation comparator on-state current	I_{SCN}	Pin 2 DC current when pin 6 becomes low to high	93.0	116.9	149.3	μA
Composite sync separation output sink current	I_{VH}	Pin 6 current, when pin 6 voltage becomes lower than 0.5 V	1.0	5.0	—	mA
Vertical sync separation block on-state voltage	V_{VSON}	Applied voltage to pin 9 when pin 7 becomes low to high	3.94	4.17	4.40	V
Vertical synchronization time constant sink current	I_{VSN}	RSET = 100 k Ω , pin 9 DC current	8.82	12.19	17.71	μA
Vertical synchronization time constant source current	I_{VSP}	RSET = 10 k Ω , pin 9 DC current	42.57	51.14	62.64	μA
Vertical synchronizing oscillation block on-state voltage	V_{VON}	Applied voltage to pin 10 when pin 7 becomes low to high	2.78	2.94	3.15	V
Vertical synchronizing oscillation block schmidt voltage	V_{VSW}	Difference between pin 10 DC voltage and V_{VON} high to low	0.83	0.90	1.01	V
Vertical synchronizing oscillation block on-state voltage	V_{VLON}	Applied voltage to pin 10 when pin 7 becomes low to high	2.47	2.65	2.79	V
Vertical synchronization output sink current	I_V	Pin 7 current, when pin 7 voltage becomes 0.5 V or less	1.0	5.0	—	mA

■ Electrical Characteristics at $V_{CC} = 5\text{ V}$, $T_a = 25^\circ\text{C}$

Parameter	Symbol	Conditions	Min	Typ	Max	Unit
Horizontal synchronizing oscillation block on-state voltage	V_{HON}	Applied voltage to pin 4 when pin 5 becomes low to high	2.80	3.00	3.18	V
Horizontal synchronizing oscillation block schmidt voltage	V_{HSW}	Applied voltage to pin 4 when Pin 5 becomes high to low	0.82	0.94	1.05	V
AFC sink current	I_{HAN}	$V_4 = V_L$, pin 3 DC current	127.2	160.0	206.0	μA
AFC source current	I_{HAP}	$V_4 = V_H$, Pin 3 DC current	124.1	158.0	206.6	μA
Horizontal synchronization sink current	I_H	Pin 5 current, when pin 5 voltage becomes under 0.5 V	1.0	5.0	—	mA
Antenna switch output sink current	I_{AS}	Antenna selection output pin on-state time DC current	10.0	30.0	—	mA
VCO time constant sink current	I_{VCN}	$V_{12} = 1.5\text{ V}$, pin 12 current	81.40	115.0	166.3	μA
VCO time constant source current	I_{VCP}	$V_{12} = 4\text{ V}$, pin 12 current	81.40	114.8	166.3	μA
Charge pump sink current	I_{CCN}	Pin 11 current after test signal 1 input	80.39	101.7	138.2	μA
Charge pump source current	I_{CCP}	Pin 11 current after test signal 2 input	80.39	108.3	138.2	μA

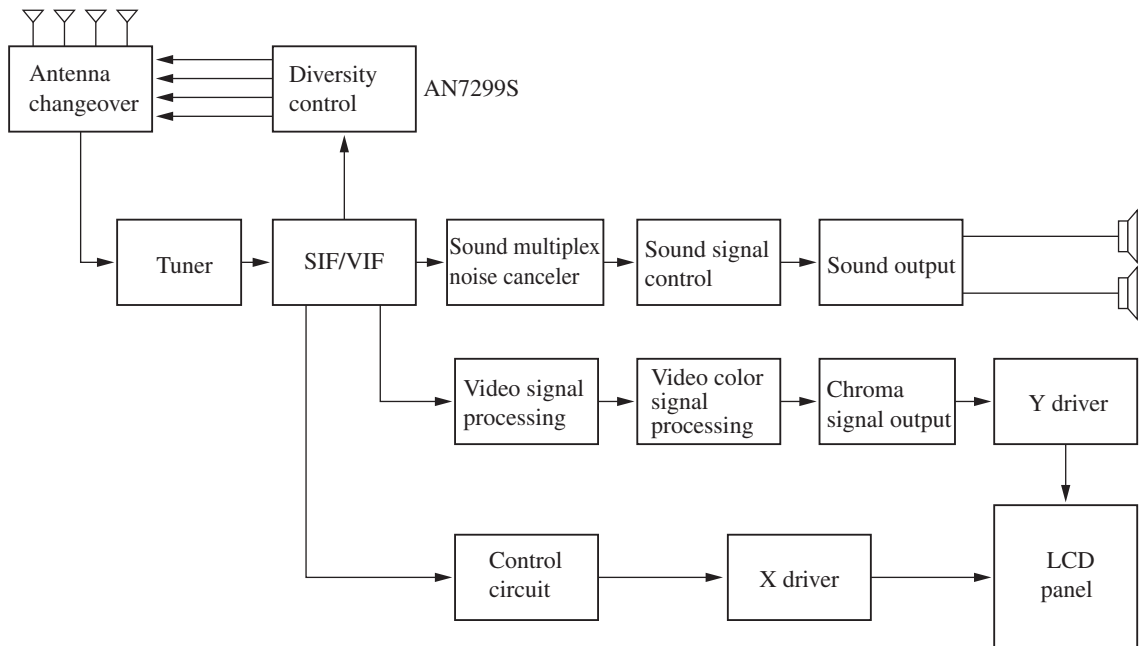
■ Application System Example

■ New Package Dimensions (Unit: mm)

- SOP024-P-0375C (Lead-free package)

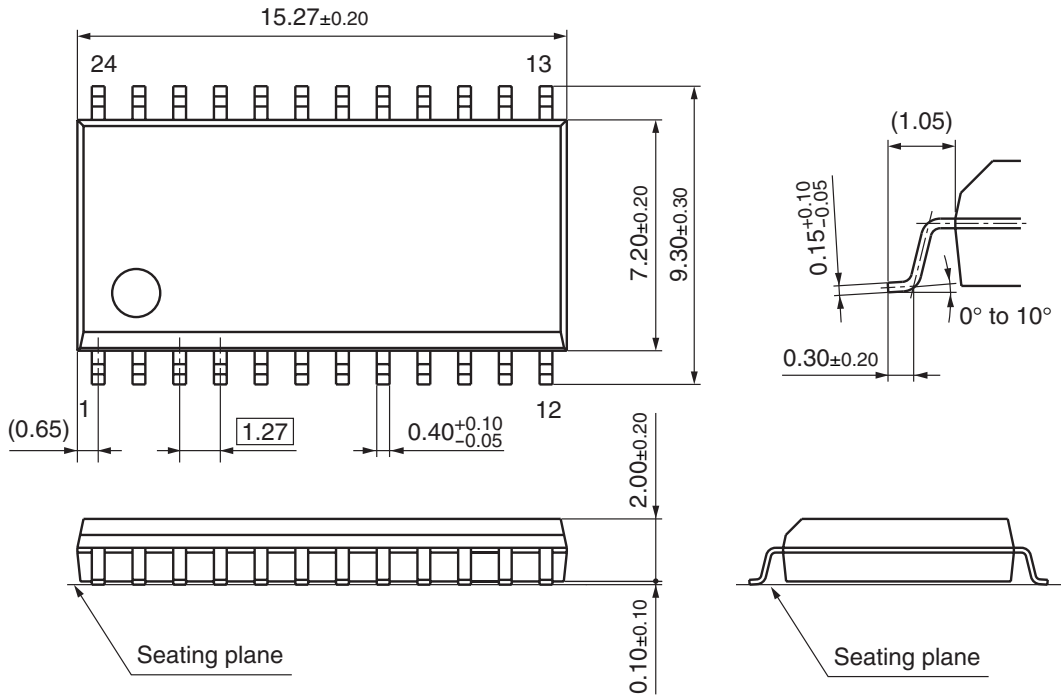

Request for your special attention and precautions in using the technical information and semiconductors described in this material

- (1) An export permit needs to be obtained from the competent authorities of the Japanese Government if any of the products or technologies described in this material and controlled under the "Foreign Exchange and Foreign Trade Law" is to be exported or taken out of Japan.
- (2) The technical information described in this material is limited to showing representative characteristics and applied circuit examples of the products. It does not constitute the warranting of industrial property, the granting of relative rights, or the granting of any license.
- (3) The products described in this material are intended to be used for standard applications or general electronic equipment (such as office equipment, communications equipment, measuring instruments and household appliances).
Consult our sales staff in advance for information on the following applications:
 - Special applications (such as for airplanes, aerospace, automobiles, traffic control equipment, combustion equipment, life support systems and safety devices) in which exceptional quality and reliability are required, or if the failure or malfunction of the products may directly jeopardize life or harm the human body.
 - Any applications other than the standard applications intended.
- (4) The products and product specifications described in this material are subject to change without notice for reasons of modification and/or improvement. At the final stage of your design, purchasing, or use of the products, therefore, ask for the most up-to-date Product Standards in advance to make sure that the latest specifications satisfy your requirements.
- (5) When designing your equipment, comply with the guaranteed values, in particular those of maximum rating, the range of operating power supply voltage and heat radiation characteristics. Otherwise, we will not be liable for any defect which may arise later in your equipment.
Even when the products are used within the guaranteed values, redundant design is recommended, so that such equipment may not violate relevant laws or regulations because of the function of our products.
- (6) When using products for which dry packing is required, observe the conditions (including shelf life and after-unpacking standby time) agreed upon when specification sheets are individually exchanged.
- (7) No part of this material may be reprinted or reproduced by any means without written permission from our company.

Please read the following notes before using the datasheets

- A. These materials are intended as a reference to assist customers with the selection of Panasonic semiconductor products best suited to their applications.
Due to modification or other reasons, any information contained in this material, such as available product types, technical data, and so on, is subject to change without notice.
Customers are advised to contact our semiconductor sales office and obtain the latest information before starting precise technical research and/or purchasing activities.
- B. Panasonic is endeavoring to continually improve the quality and reliability of these materials but there is always the possibility that further rectifications will be required in the future. Therefore, Panasonic will not assume any liability for any damages arising from any errors etc. that may appear in this material.
- C. These materials are solely intended for a customer's individual use.
Therefore, without the prior written approval of Panasonic, any other use such as reproducing, selling, or distributing this material to a third party, via the Internet or in any other way, is prohibited.



LittleDiode supplies new, hard to find or obsolete electronic components and semiconductors all over the world.

With over two million different components listed you are sure to find the part you need.

Feel free to visit us today at our online store:

LittleDiode.com

Looking forward to providing you with the best possible service.