

Agilent HSMx-C177, HSMx-C197 Low Profile Chip LEDs

Data Sheet

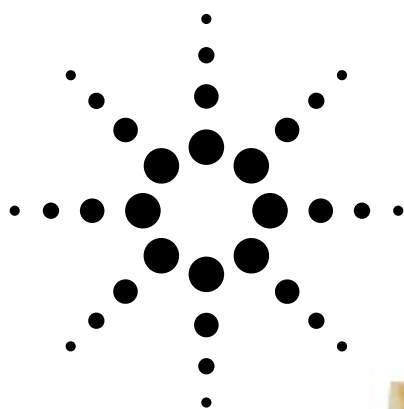

Description

The HSMx-C177 and HSMx-C197 ChipLEDs are designed specifically for the membrane switch application. The request is to have the height as low as possible while retaining the footprint at the optimal size of a 0805 (2.0 x 1.25 mm) or 0603 (1.6 x 0.8 mm) device. Apart from the membrane switch application, the HSMx-C177 is also suitable for use in applications where low height is required.

Seven different colors are available: green, red, yellow, orange, deep red, blue, and amber. All parts are intensity binned and color binned (except for red color). They come in 8 mm tape on a 7 inch diameter reel with 4000 units per reel which makes them compatible for automatic placement.

Device Selection Guide

AS AlInGaP

Product Number	Color	Package Description
HSMA-C177/C197	Amber	Untinted, Diffused
HSMT-C177/C197	Deep Red	Untinted, Diffused
HSMC-C177/C197	Red	Untinted, Diffused
HSML-C177/C197	Orange	Untinted, Diffused

GaP

Product Number	Color	Package Description
HSMG-C177/C197	Green	Untinted, Diffused
HSMD-C177/C197	Orange	Untinted, Diffused
HSMS-C177/C197	HER	Untinted, Diffused
HSMY-C177/C197	Yellow	Untinted, Diffused

InGaN

Product Number	Color	Package Description
HSMQ-C177/C197	Green	Untinted, Diffused
HSMR-C177/C197	Blue	Untinted, Diffused

Features

- Small size with extremely low profile
- 0805 or 0603 industry standard footprint with 0.4 mm height
- Diffused optics
- Operating temperature range of -30°C to $+85^{\circ}\text{C}$
- Compatible with IR soldering
- Available in 7 colors
- Available in 8 mm tape on 7" diameter reel
- Reel sealed in zip locked moisture barrier bags

Applications

- Membrane switch indicator
- LCD backlighting
- Push button backlighting
- Front panel indicator
- Symbol backlighting
- Keypad backlighting



Package Dimensions

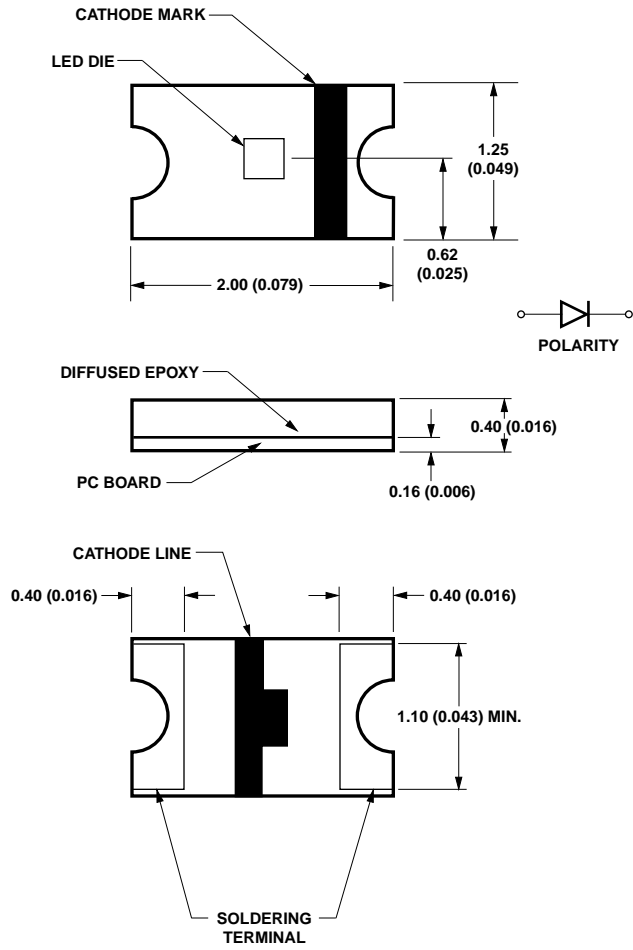

HSMx-C177

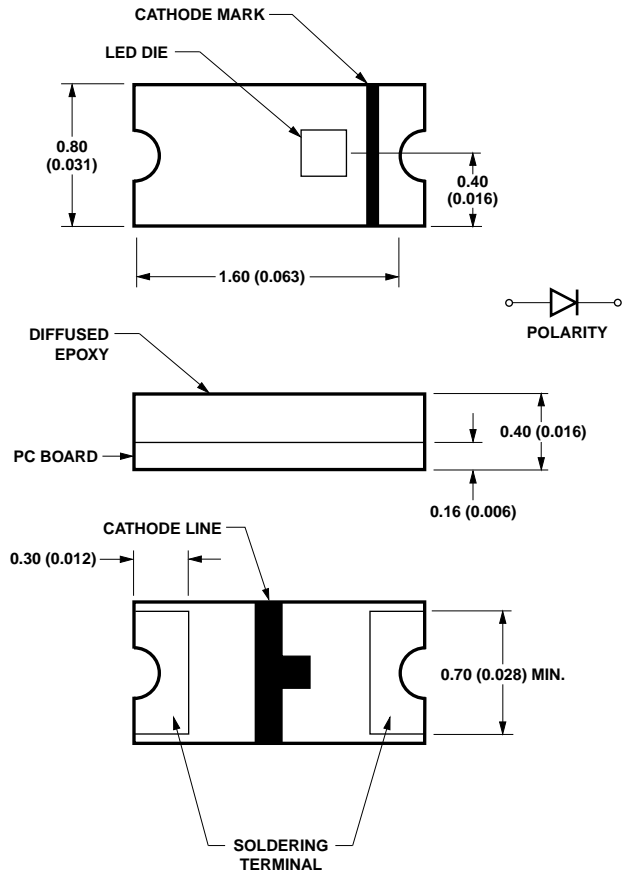

HSMx-C197

- NOTES:**
 1. ALL DIMENSIONS IN MILLIMETERS (INCHES).
 2. TOLERANCE IS ± 0.1 mm (± 0.004 IN.) UNLESS OTHERWISE SPECIFIED.

Absolute Maximum Ratings at T_A = 25°C

Parameter	HSMA/C/L-C177/C197, HSMT-C177/C197			Units
	HSMG/D/S/Y-C177/C197	HSMQ/R-C177/C197		
DC Forward Current [1]	25	20	20	mA
Peak Pulsing Current[2]	100	100	100	mA
Power Dissipation	64	54	78	mW
Reverse Voltage (I _R = 100 μA)	5	5	5	V
LED Junction Temperature	95	95	95	°C
Operating Temperature Range	-30 to +85	-30 to +85	-30 to +85	°C
Storage Temperature Range	-40 to +85	-40 to +85	-40 to +85	°C
Soldering Temperature	See IR soldering profile (Figure 7)			

Notes:

1. Derate linearly as shown in Figure 4.
2. Pulse condition of 1/10 duty and 0.1 ms width.

Electrical Characteristics at T_A = 25°C

Part Number	Forward Voltage V _F (Volts) @ I _F = 20 mA		Reverse Breakdown V _R (Volts) @ I _R = 100 μA Min.	Capacitance C (pF), V _F = 0, f = 1 MHz Typ.	Thermal Resistance R _{θJ-PIN} (°C/W) Typ.
	Typ.	Max.			
HSMA-C177/197	1.9	2.4	5	11	300
HSMC-C177/197	1.9	2.4	5	15	300
HSML-C177/197	1.9	2.4	5	20	300
HSMT-C177/197	1.9	2.4	5	15	300
HSMG-C177/197	2.2	2.6	5	9	250
HSMD-C177/197	2.2	2.6	5	7	250
HSMS-C177/197	2.1	2.6	5	5	250
HSMY-C177/197	2.1	2.6	5	6	250
HSMQ-C177/197	3.4	3.9	5	110	350
HSMR-C177/197	3.4	3.9	5	110	350

V_F Tolerance: ± 0.1 V

Optical Characteristics at T_A = 25°C

Part Number	Color	Luminous Intensity I _v (mcd) @ 20 mA ^[1]		Peak Wavelength λ _{peak} (nm) Typ.	Color, Dominant Wavelength λ _d ^[2] (nm) Typ.	Viewing Angle 2 θ _{1/2} Degrees ^[3] Typ.	Luminous Efficacy η _v (lm/w) Typ.
		Min.	Typ.				
HSMA-C177/197	AS Amber	25	90	595	592	130	480
HSMC-C177/197	AS Red	25	90	637	626	130	155
HSML-C177/197	AS Orange	25	90	609	605	130	370
HSMT-C177/197	AS Deep Red	10	30	660	639	130	70
HSMG-C177/197	GaP Green	4.0	15	570	572	130	595
HSMD-C177/197	GaP Orange	2.5	8	605	604	130	380
HSMS-C177/197	HER	2.5	10	630	626	130	145
HSMY-C177/197	GaP Yellow	2.5	8	589	586	130	500
HSMQ-C177/197	InGaN Green	40	145	520	527	130	510
HSMR-C177/197	InGaN Blue	16	55	469	473	130	88

Notes:

1. The luminous intensity, I_v, is measured at the peak of the spatial radiation pattern which may not be aligned with the mechanical axis of the lamp package.
2. The dominant wavelength, λ_d, is derived from the CIE Chromaticity Diagram and represents the perceived color of the device.
3. θ_{1/2} is the off-axis angle where the luminous intensity is 1/2 the peak intensity.

Color Bin Limits

Green Color Bins ^[1]		
Dom. Wavelength (nm)		
Bin ID	Min.	Max.
A	561.5	564.5
B	564.5	567.5
C	567.5	570.5
D	570.5	573.5
E	573.5	576.5

Tolerance: ± 0.5 nm

Blue Color Bins ^[1]		
Dom. Wavelength (nm)		
Bin ID	Min.	Max.
A	460.0	465.0
B	465.0	470.0
C	470.0	475.0
D	475.0	480.0

Tolerance: ± 1 nm

Orange Color Bins^[1]		
Dom. Wavelength (nm)		
Bin ID	Min.	Max.
A	597.0	600.0
B	600.0	603.0
C	603.0	606.0
D	606.0	609.0
E	609.0	612.0
F	612.0	615.0

Tolerance: ± 1 nm

Yellow/Amber Color Bins^[1]		
Dom. Wavelength (nm)		
Bin ID	Min.	Max.
A	582.0	584.5
B	584.5	587.0
C	587.0	589.5
D	589.5	592.0
E	592.0	594.5
F	594.5	597.0

Tolerance: ± 0.5 nm

InGaN Green Color Bins^[1]		
Dom. Wavelength (nm)		
Bin ID	Min.	Max.
A	515.0	520.0
B	520.0	525.0
C	525.0	530.0
D	530.0	535.0

Tolerance: ± 1 nm

Note:

1. Bin categories are established for classification of products. Products may not be available in all categories. Please contact your Agilent representative for information on currently available bins.

Light Intensity (Iv) Bin Limits^[1]		
Intensity (mcd)		
Bin ID	Min.	Max.
A	0.11	0.18
B	0.18	0.29
C	0.29	0.45
D	0.45	0.72
E	0.72	1.10
F	1.10	1.80
G	1.80	2.80
H	2.80	4.50
J	4.50	7.20
K	7.20	11.20
L	11.20	18.00
M	18.00	28.50
N	28.50	45.00
P	45.00	71.50
Q	71.50	112.50
R	112.50	180.00
S	180.00	285.00
T	285.00	450.00
U	450.00	715.00
V	715.00	1125.00
W	1125.00	1800.00
X	1800.00	2850.00
Y	2850.00	4500.00

Tolerance: $\pm 15\%$

Note:

1. Bin categories are established for classification of products. Products may not be available in all categories. Please contact your Agilent representative for information on currently available bins.

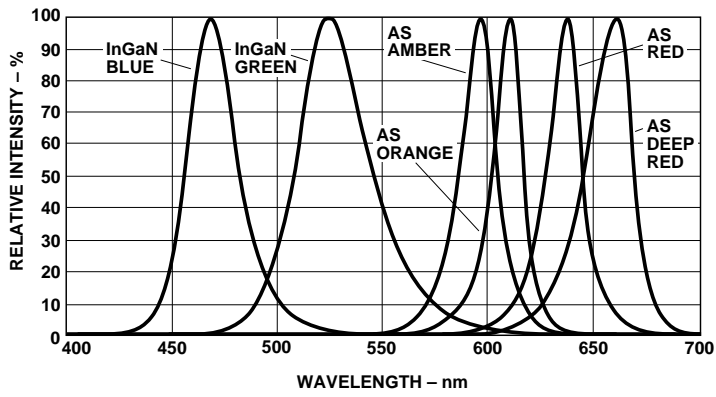

Figure 1a. Relative intensity vs. wavelength.

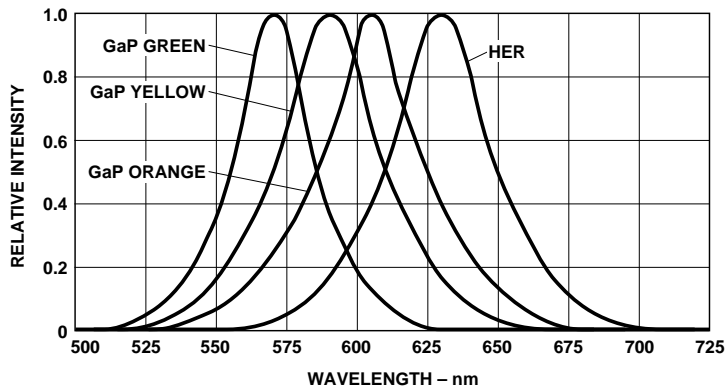

Figure 1b. Relative intensity vs. wavelength.

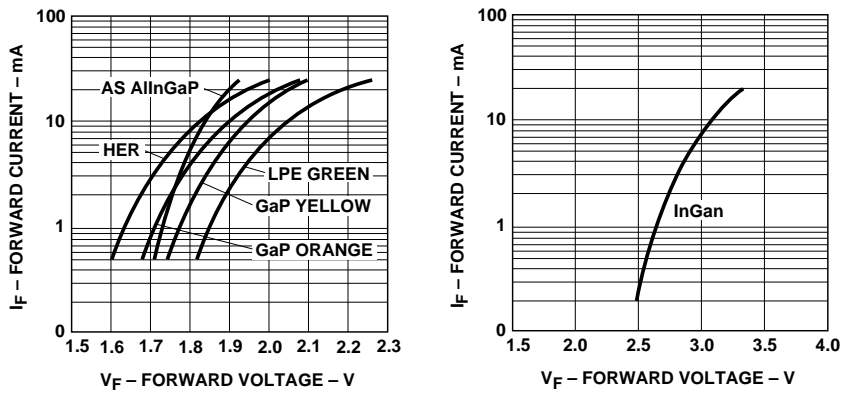

Figure 2. Forward current vs. forward voltage.

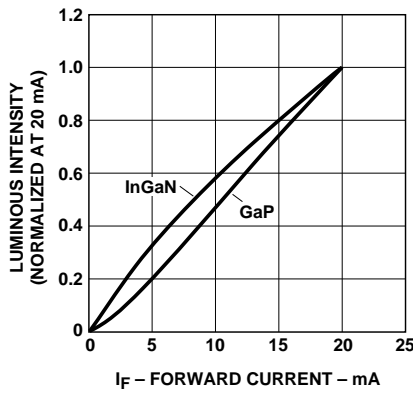

Figure 3. Luminous intensity vs. forward current.

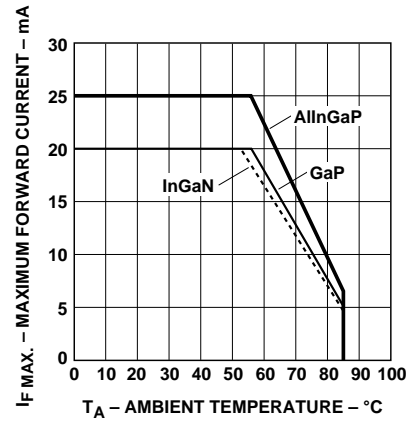
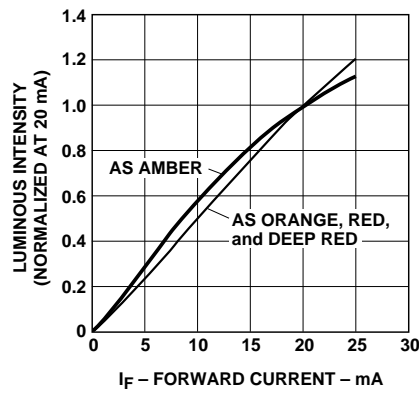

Figure 4. Maximum forward current vs. ambient temperature.

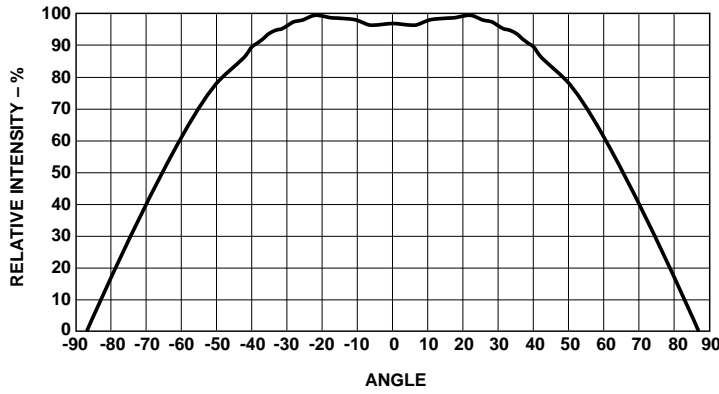

Figure 5. Relative intensity vs. angle.

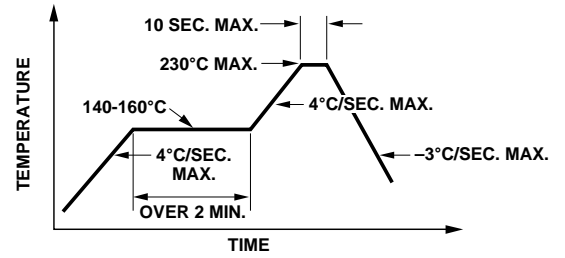

Figure 6. Recommended reflow soldering profile.

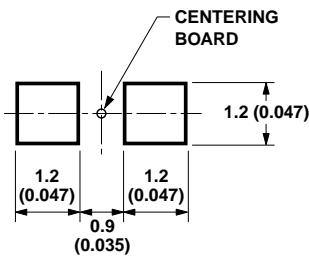

Figure 7. Recommended soldering pattern for HSMx-C177.

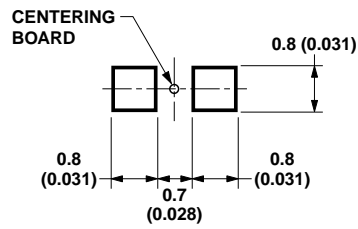

Figure 8. Recommended soldering pattern for HSMx-C197.

NOTE:
1. ALL DIMENSIONS IN MILLIMETERS (INCHES).

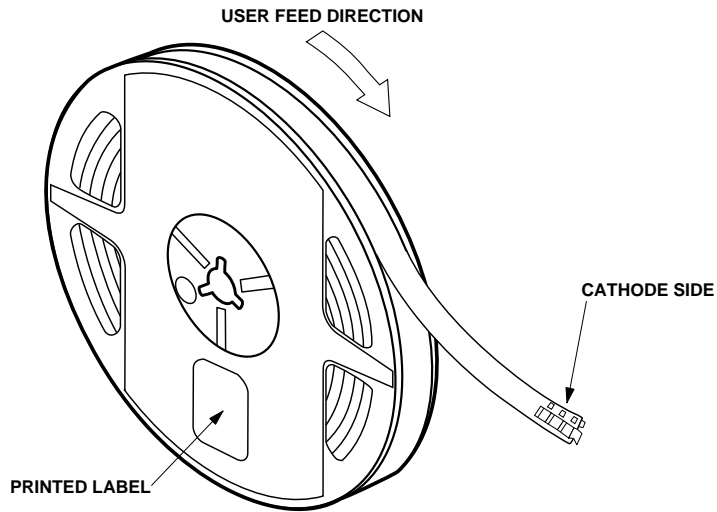

Figure 9. Reeling orientation.

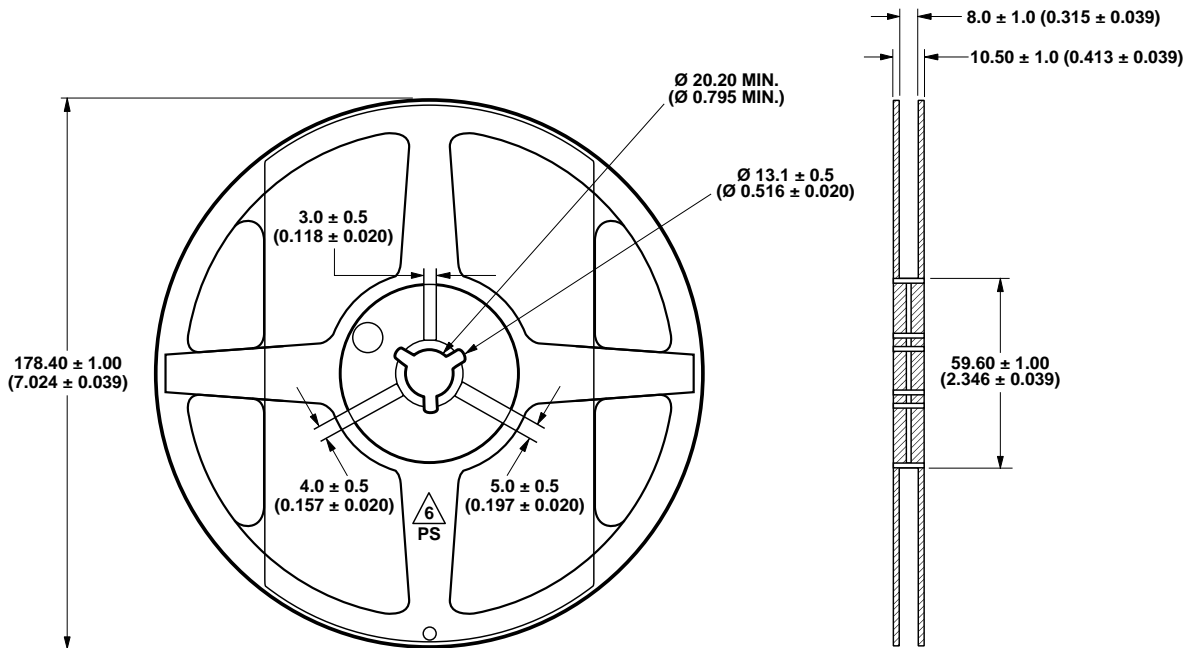

Figure 10. Reel dimensions.

NOTE:

1. ALL DIMENSIONS IN MILLIMETERS (INCHES).

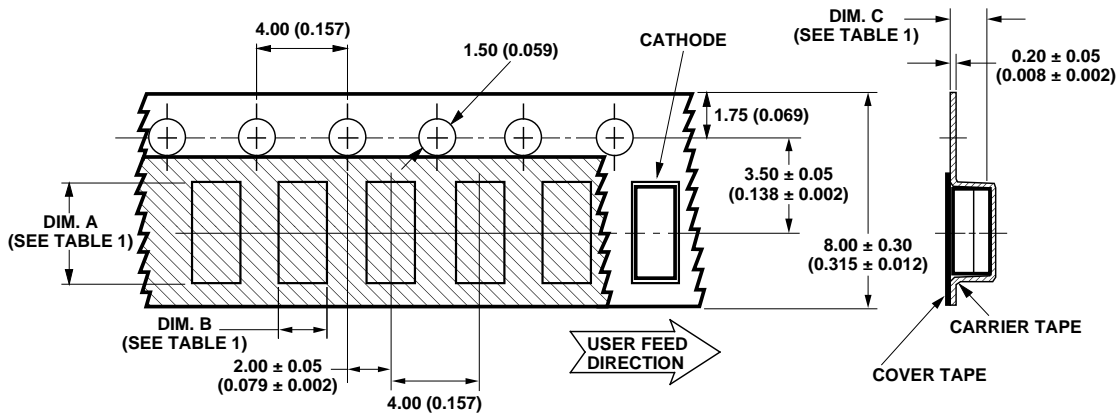

TABLE 1
DIMENSIONS IN MILLIMETERS (INCHES)

PART NUMBER	DIM. A ± 0.10 (± 0.004)	DIM. B ± 0.10 (± 0.004)	DIM. C ± 0.10 (± 0.004)
HSMx-C177 SERIES	2.40 (0.094)	1.60 (0.063)	0.65 (0.025)
HSMx-C197 SERIES	1.80 (0.071)	0.95 (0.037)	0.60 (0.024)

Figure 11. Tape dimensions.

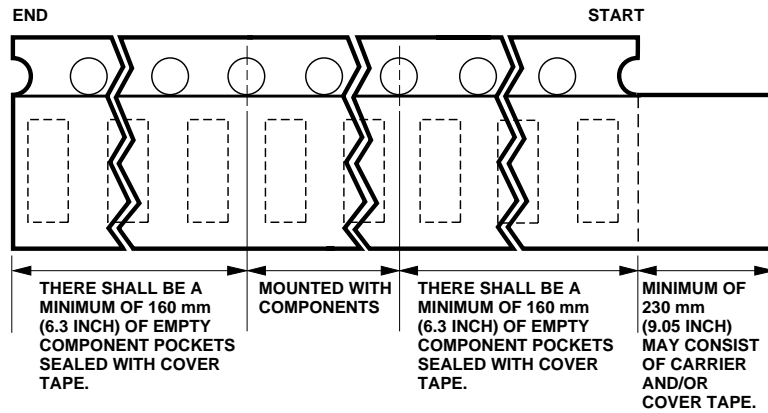

Figure 12. Tape leader and trailer dimensions.

NOTES:

1. ALL DIMENSIONS IN MILLIMETERS (INCHES).
2. TOLERANCE IS ± 0.1 mm (± 0.004 IN.) UNLESS OTHERWISE SPECIFIED.

Convective IR Reflow Soldering

For more information on IR reflow soldering, refer to Application Note 1060, *Surface Mounting SMT LED Indicator Components*.

Storage Condition:

5 to 30°C @ 60% RH max.

Baking is required under the condition:

- a) the blue silica gel indicator becoming white/transparent color
- b) the pack has been open for more than 1 week

Baking recommended condition:
60 ± 5°C for 20 hours.

www.agilent.com/semiconductors

For product information and a complete list of distributors, please go to our web site.

For technical assistance call:

Americas/Canada: +1 (800) 235-0312 or
(408) 654-8675

Europe: +49 (0) 6441 92460

China: 10800 650 0017

Hong Kong: (+65) 271 2451

India, Australia, New Zealand: (+65) 271 2394

Japan: (+81 3) 3335-8152(Domestic/International), or 0120-61-1280(Domestic Only)

Korea: (+65) 271 2194

Malaysia, Singapore: (+65) 271 2054

Taiwan: (+65) 271 2654

Data subject to change.

Copyright © 2002 Agilent Technologies, Inc.

Obsoletes 5988-3043EN

January 27, 2002

5988-5501EN



Agilent Technologies



LittleDiode supplies new, hard to find or obsolete electronic components and semiconductors all over the world.

With over two million different components listed you are sure to find the part you need.

Feel free to visit us today at our online store:

LittleDiode.com

Looking forward to providing you with the best possible service.