

# FSQ510, FSQ510H, and FSQ510M

## Green Mode Fairchild Power Switch (FPS™)

### for Valley Switching Converter – *Low EMI and High Efficiency*

#### Features

- Uses an LDMOS Integrated Power Switch
- Optimized for Valley Switching Converter (VSC)
- Low EMI through Variable Frequency Control and Inherent Frequency Modulation
- High Efficiency through Minimum Drain Voltage Switching
- Extended Valley Switching for Wide Load Ranges
- Small Frequency Variation for Wide Load Ranges
- Advanced Burst-Mode Operation for Low Standby Power Consumption
- Pulse-by-Pulse Current Limit
- Protection Functions: Overload Protection (OLP), Internal Thermal Shutdown (TSD) with Hysteresis
- Under-Voltage Lockout (UVLO) with Hysteresis
- Internal Startup Circuit
- Internal High-Voltage SenseFET: 700V
- Built-in Soft-Start: 5ms

#### Applications

- Auxiliary Power Supplies for LCD TV, LCD Monitor, Personal Computer, and White Goods

#### Description

A Valley Switching Converter (VSC) generally shows lower EMI and higher power conversion efficiency than a conventional hard-switched converter with a fixed switching frequency. The FSQ510 (H or M) is an integrated valley switching pulse width modulation (VS-PWM) controller and SenseFET specifically designed for offline switch-mode power supplies (SMPS) for valley switching with minimal external components. The VS-PWM controller includes an integrated oscillator, under-voltage lockout (UVLO), leading-edge blanking (LEB), optimized gate driver, internal soft-start, temperature-compensated precise current sources for loop compensation, and self-protection circuitry.

Compared with discrete MOSFET and PWM controller solutions, the FSQ510 (H or M) can reduce total cost, component count, size and weight; while simultaneously increasing efficiency, productivity, and system reliability. This device provides a platform for cost-effective designs of a valley switching flyback converters.

#### Ordering Information

Part Number	Package	Eco Status	Operating Junction Temperature	Current Limit	R <sub>DS(ON)</sub> (MAX)	Output Power Table <sup>(1)</sup>				Replaces Devices
						230V <sub>AC</sub> ± 15% <sup>(2)</sup>		85-265V <sub>AC</sub>		
						Adapter <sup>(3)</sup>	Open Frame <sup>(4)</sup>	Adapter <sup>(3)</sup>	Open Frame <sup>(4)</sup>	
FSQ510	7-DIP	RoHS	-40 to +130°C	320mA	32Ω	5.5W	9W	4W	6W	FSD210B
FSQ510H	8-DIP									FSD210DH
FSQ510M	7-MLSOP									FSD210BM

 For Fairchild's definition of "green" Eco Status, please visit: [http://www.fairchildsemi.com/company/green/rohs\\_green.html](http://www.fairchildsemi.com/company/green/rohs_green.html).

#### Notes:

1. The junction temperature can limit the maximum output power.
2. 230V<sub>AC</sub> or 100/115V<sub>AC</sub> with voltage doubler.
3. Typical continuous power with a Fairchild charger evaluation board described in this datasheet in a non-ventilated, enclosed adapter housing, measured at 50°C ambient temperature.
4. Maximum practical continuous power for auxiliary power supplies in an open-frame design at 50°C ambient temperature.

FSQ510, FSQ510H, and FSQ510M — Green Mode Fairchild Power Switch (FPS™) for Valley Switching Converter

### Application Circuit

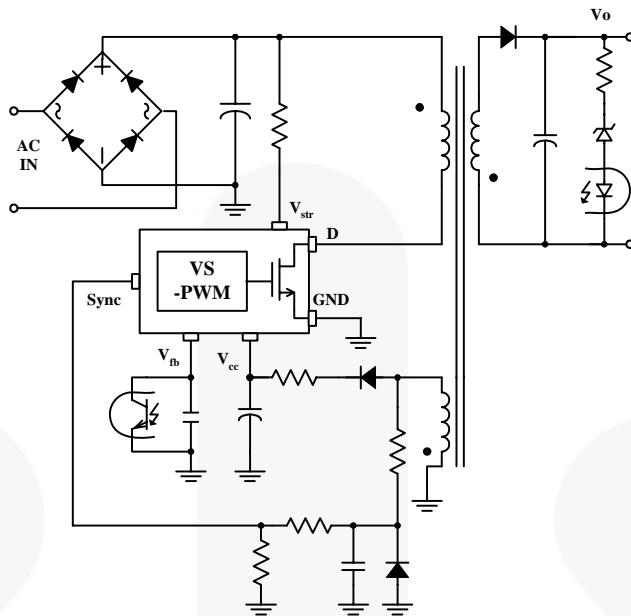


Figure 1. Typical Application Circuit

### Internal Block Diagram

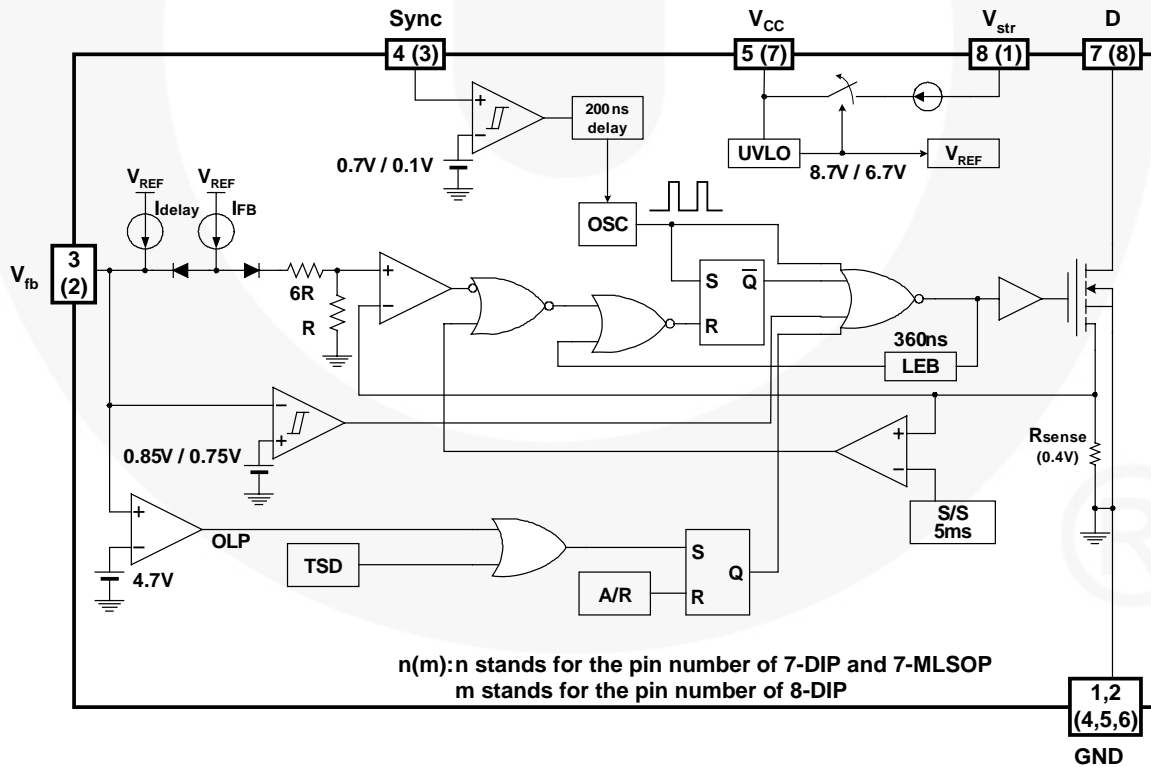


Figure 2. Internal Block Diagram

## Pin Assignments

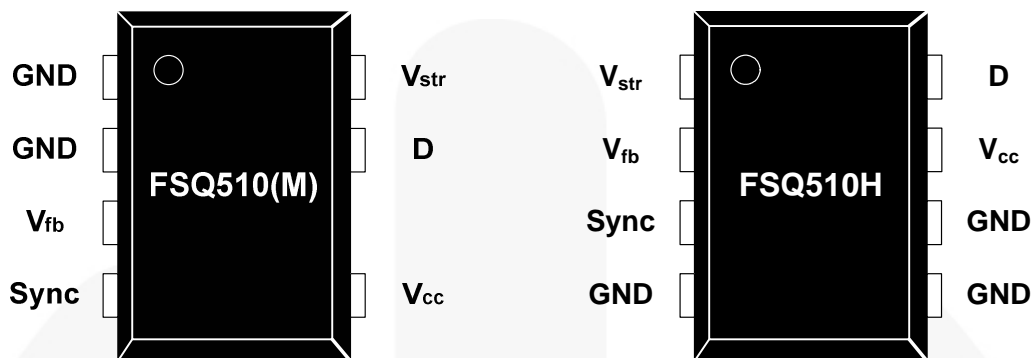


Figure 3. Package Diagrams for FSQ510(M) and FSQ510H

## Pin Definitions

7-Pin	8-Pin	Name	Description
1, 2	4, 5, 6	GND	This pin is the control ground and the SenseFET source.
3	2	$V_{fb}$	This pin is internally connected to the inverting input of the PWM comparator. The collector of an opto-coupler is typically tied to this pin. For stable operation, a capacitor should be placed between this pin and GND. If the voltage of this pin reaches 4.7V, the overload protection triggers, which shuts down the FPS.
4	3	Sync	This pin is internally connected to the sync-detect comparator for valley switching. In normal valley-switching operation, the threshold of the sync comparator is 0.7V/0.1V.
5	7	$V_{cc}$	This pin is the positive supply input. This pin provides internal operating current for both startup and steady-state operation.
7	8	D	High-voltage power SenseFET drain connection.
8	1	$V_{str}$	This pin is connected directly, or through a resistor, to the high-voltage DC link. At startup, the internal high-voltage current source supplies internal bias and charges the external capacitor connected to the $V_{cc}$ pin. Once $V_{cc}$ reaches 8.7V, the internal current source is disabled.

## Absolute Maximum Ratings

Stresses exceeding the absolute maximum ratings may damage the device. The device may not function or be operable above the recommended operating conditions and stressing the parts to these levels is not recommended. In addition, extended exposure to stresses above the recommended operating conditions may affect device reliability. The absolute maximum ratings are stress ratings only.

Symbol	Parameter	Min.	Max.	Unit
V <sub>STR</sub>	V <sub>str</sub> Pin Voltage		500	V
V <sub>DS</sub>	Drain Pin Voltage		700	V
V <sub>CC</sub>	Supply Voltage		20	V
V <sub>FB</sub>	Feedback Voltage Range	-0.3	Internally Clamped <sup>(5)</sup>	V
V <sub>Sync</sub>	Sync Pin Voltage	-0.3	6.5	V
P <sub>D</sub>	Total Power Dissipation	7-DIP	1.38	W
		7-MLSOP		
		8-DIP	1.47	
T <sub>J</sub>	Maximum Junction Temperature		+150	°C
	Recommended Operating Junction Temperature <sup>(6)</sup>	-40	+140	
T <sub>STG</sub>	Storage Temperature	-55	+150	°C

### Notes:

- V<sub>FB</sub> is internally clamped at 6.5V (I<sub>CLAMP\_MAX</sub><100uA) which has a tolerance between 6.2V and 7.2V.
- The maximum value of the recommended operating junction temperature is limited by thermal shutdown.

## Thermal Impedance

T<sub>A</sub>=25°C unless otherwise specified. Items are tested with the standards JESD 51-2 and 51-10 (DIP).

Symbol	Parameter	Value	Unit
7-DIP, 7-MLSOP			
θ <sub>JA</sub>	Junction-to-Ambient Thermal Impedance <sup>(7)</sup>	90	°C/W
θ <sub>JC</sub>	Junction-to-Case Thermal Impedance <sup>(8)</sup>	13	°C/W
8-DIP			
θ <sub>JA</sub>	Junction-to-Ambient Thermal Impedance <sup>(7)</sup>	85	°C/W
θ <sub>JC</sub>	Junction-to-Case Thermal Impedance <sup>(8)</sup>	13	°C/W

### Notes:

- Free-standing with no heatsink; without copper clad; measurement condition - just before junction temperature T<sub>J</sub> enters into TSD.
- Measured on the DRAIN pin close to plastic interface.

## Electrical Characteristics

T<sub>J</sub>=25°C unless otherwise specified.

Symbol	Parameter	Conditions	Min.	Typ.	Max.	Unit
<b>SenseFET Section</b>						
BV <sub>DSS</sub>	Drain-Source Breakdown Voltage	V <sub>CC</sub> =0V, I <sub>D</sub> =100μA	700			V
I <sub>DSS</sub>	Zero-Gate-Voltage Drain Current	V <sub>DS</sub> =700V			150	μA
R <sub>DS(ON)</sub>	Drain-Source On-State Resistance	T <sub>J</sub> =25°C, I <sub>D</sub> =180mA		28	32	□
		T <sub>J</sub> =100°C, I <sub>D</sub> =180mA		42	48	□
C <sub>ISS</sub>	Input Capacitance <sup>(9)</sup>	V <sub>GS</sub> =11V		96		pF
C <sub>OSS</sub>	Output Capacitance <sup>(9)</sup>	V <sub>DS</sub> =40V		28		pF
t <sub>r</sub>	Rise Time <sup>(9)</sup>	V <sub>DS</sub> =350V, I <sub>D</sub> =25mA		100		ns
t <sub>f</sub>	Fall Time <sup>(9)</sup>	V <sub>DS</sub> =350V, I <sub>D</sub> =25mA		50		ns
<b>Control Section</b>						
f <sub>S</sub>	Initial Switching Frequency	V <sub>CC</sub> =11V, V <sub>FB</sub> =5V, V <sub>sync</sub> =0V	87.7	94.3	100.0	kHz
Δf <sub>S</sub>	Switching Frequency Variation <sup>(9)</sup>	-25°C < T <sub>J</sub> < 125°C		±5	±8	%
I <sub>FB</sub>	Feedback Source Current	V <sub>CC</sub> =11V, V <sub>FB</sub> =0V	200	225	250	μA
t <sub>B</sub>	Switching Blanking Time	V <sub>CC</sub> =11V, V <sub>FB</sub> =1V, V <sub>sync</sub> Frequency Sweep	7.2	7.6	8.2	μs
t <sub>W</sub>	Valley Detection Window Time <sup>(9)</sup>			3.0		μs
D <sub>MAX</sub>	Maximum Duty Ratio	V <sub>CC</sub> =11V, V <sub>FB</sub> =3V	54	60	66	%
D <sub>MIN</sub>	Minimum Duty Ratio	V <sub>CC</sub> =11V, V <sub>FB</sub> =0V			0	%
V <sub>START</sub>	UVLO Threshold Voltage	V <sub>FB</sub> =0V, V <sub>CC</sub> Sweep	8.0	8.7	9.4	V
V <sub>STOP</sub>		After Turn-on, V <sub>FB</sub> =0V	6.0	6.7	7.4	V
t <sub>S/S</sub>	Internal Soft-Start Time	V <sub>STR</sub> =40V, V <sub>CC</sub> Sweep	3	5	7	ms
<b>Burst-Mode Section</b>						
V <sub>BURH</sub>	Burst-Mode Voltage	V <sub>CC</sub> =11V, V <sub>FB</sub> Sweep	0.75	0.85	0.95	V
V <sub>BURL</sub>			0.65	0.75	0.85	V
HYS				100		mV
<b>Protection Section</b>						
I <sub>LIM</sub>	Peak Current Limit	di/dt=90mA/μs	280	320	360	mA
V <sub>SD</sub>	Shutdown Feedback Voltage	V <sub>DS</sub> =40V, V <sub>CC</sub> =11V, V <sub>FB</sub> Sweep	4.2	4.7	5.2	V
I <sub>DELAY</sub>	Shutdown Delay Current	FSQ510H	4	5	6	μA
		FSQ510(M)	3.5	4.5	5.5	
t <sub>LEB</sub>	Leading-Edge Blanking Time <sup>(9)</sup>			360		ns
T <sub>SD</sub>	Thermal Shutdown Temperature <sup>(9)</sup>		130	140	150	°C
HYS				60		°C
<b>Synchronous Section</b>						
V <sub>SH</sub>	Synchronous Threshold Voltage	V <sub>CC</sub> =11V, V <sub>FB</sub> =1V	0.55	0.70	0.85	V
V <sub>SL</sub>		V <sub>CC</sub> =11V, V <sub>FB</sub> =1V	0.05	0.10	0.15	V
t <sub>sync</sub>	Synchronous Delay Time		180	200	220	ns
<b>Total Device Section</b>						
I <sub>OP</sub>	Operating Supply Current (Control Part Only)	V <sub>CC</sub> =11V, V <sub>FB</sub> =5.5V		0.8	1.0	mA
I <sub>CH</sub>	Startup Charging Current	V <sub>CC</sub> =V <sub>FB</sub> =0V, V <sub>STR</sub> =40V		1.0	1.2	mA
V <sub>STR</sub>	Supply Voltage	V <sub>CC</sub> =V <sub>FB</sub> =0V, V <sub>STR</sub> Sweep		27		V

**Note:**

9. These parameters, although guaranteed, are not 100% tested in production.

## Comparison between FSD210B and FSQ510

Function	FSD210B	FSQ510	Advantages of FSQ510
Control Mode	Voltage Mode	Current Mode	Fast Response Easy-to-Design Control Loop
Operation Method	Constant Frequency PWM	Valley Switching Operation	Turn-on at Minimum Drain Voltage High Efficiency and Low EMI
EMI Reduction Method	Frequency Modulation	Valley Switching	Frequency Variation Depending on the Ripple of DC Link Voltage High Efficiency and Low EMI
Soft-Start	3ms (Built-in)	5ms (Built-in)	Longer Soft-Start Time
Protection	TSD	TSD with Hysteresis	Enhanced Thermal Shutdown Protection
Power Balance	Long T <sub>CLD</sub>	Short T <sub>CLD</sub>	Small Difference of Input Power between the Low and High Input Voltage Cases
Power Ratings	Less than 5W Under Open-Frame Condition at the Universal Line Input	More than 6W Under Open-Frame Condition at the Universal Line Input	More Output Power Rating Available due to the Valley Switching

## Typical Performance Characteristics

Characteristic graphs are normalized at  $T_A=25^\circ\text{C}$ .

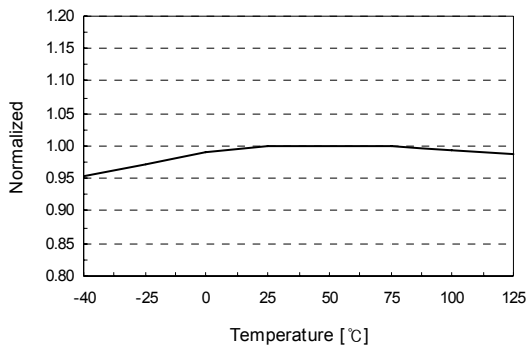


Figure 4. Operating Frequency ( $f_{osc}$ ) vs.  $T_A$

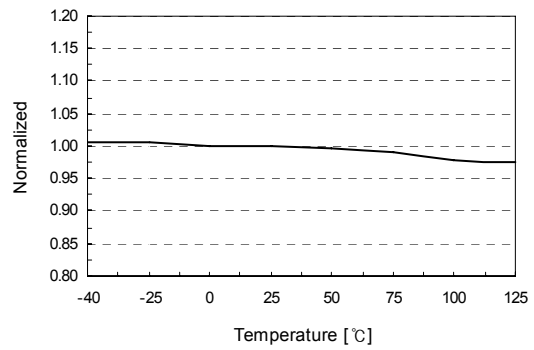


Figure 5. Peak Current Limit ( $I_{LIM}$ ) vs.  $T_A$

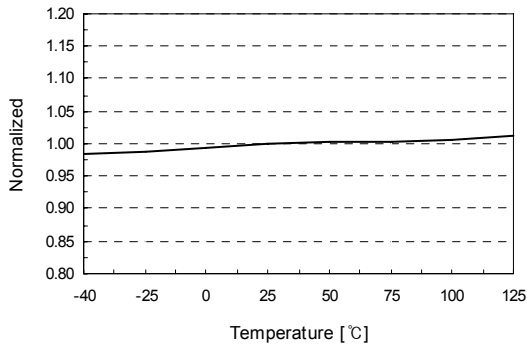


Figure 6. Start Threshold Voltage ( $V_{START}$ ) vs.  $T_A$

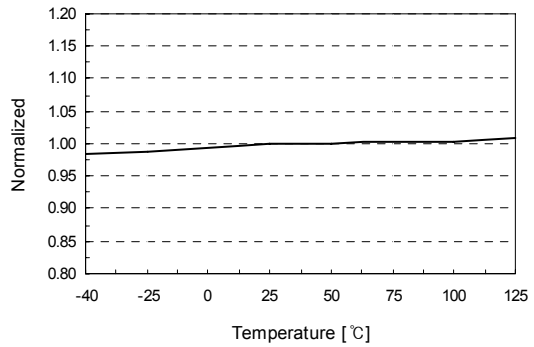


Figure 7. Stop Threshold Voltage ( $V_{STOP}$ ) vs.  $T_A$

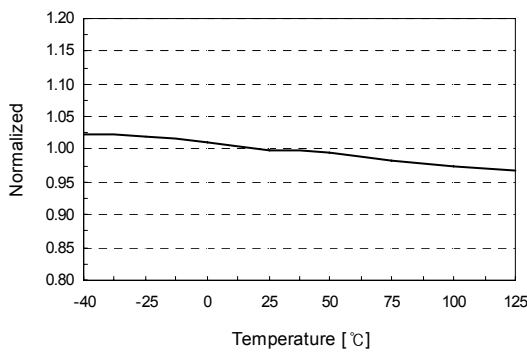


Figure 8. Shutdown Feedback Voltage ( $V_{SD}$ ) vs.  $T_A$

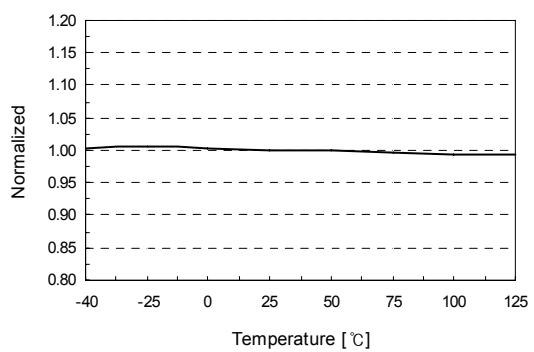


Figure 9. Maximum Duty Cycle ( $D_{MAX}$ ) vs.  $T_A$

Typical Performance Characteristics (Continued)

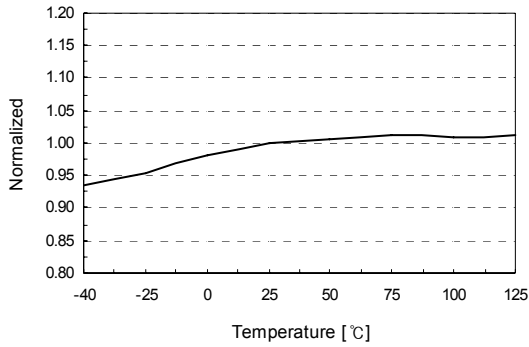


Figure 10. Feedback Source Current (I<sub>FB</sub>) vs. T<sub>A</sub>

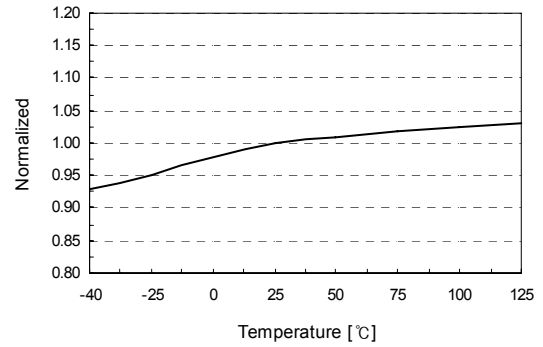


Figure 11. Shutdown Delay Current (I<sub>DELAY</sub>) vs. T<sub>A</sub>

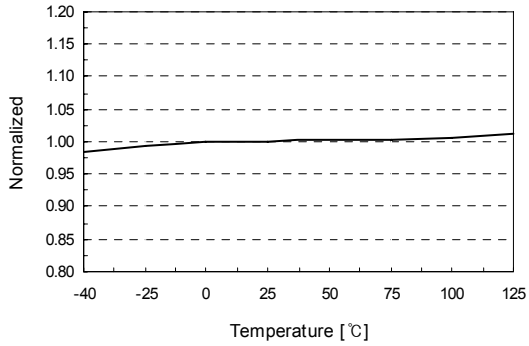


Figure 12. Operating Supply Current (I<sub>OP</sub>) vs. T<sub>A</sub>



## Functional Description

**1. Startup:** At startup, an internal high-voltage current source supplies the internal bias and charges the external capacitor ( $C_a$ ) connected to the  $V_{CC}$  pin, as illustrated in Figure 13. When  $V_{CC}$  reaches 8.7V, the FPS begins switching and the internal high-voltage current source is disabled. The FPS continues normal switching operation and the power is supplied from the auxiliary transformer winding unless  $V_{CC}$  goes below the stop voltage of 6.7V.

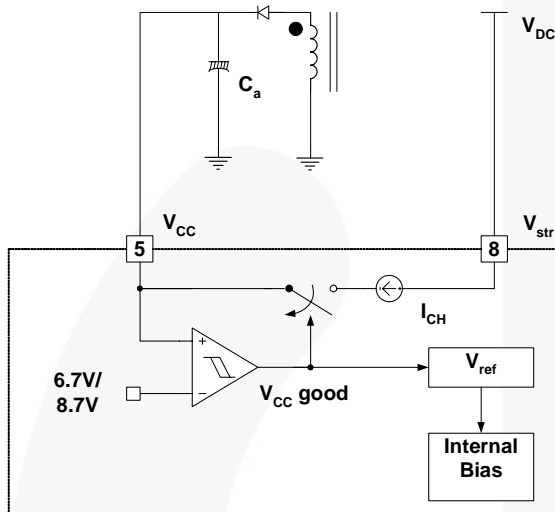


Figure 13. Startup Block

**2. Feedback Control:** This device employs current-mode control, as shown in Figure 14. An opto-coupler (such as the FOD817) and shunt regulator (such as the KA431) are typically used to implement the feedback network. Comparing the feedback voltage with the voltage across the  $R_{sense}$  resistor makes it possible to control the switching duty cycle. When the reference pin voltage of the shunt regulator exceeds the internal reference voltage of 2.5V, the opto-coupler LED current increases, pulling down the feedback voltage and reducing the drain current. This typically occurs when the input voltage is increased or the output load is decreased.

**2.1 Pulse-by-Pulse Current Limit:** Because current-mode control is employed, the peak current through the SenseFET is limited by the inverting input of PWM comparator ( $V_{FB}^*$ ), as shown in Figure 14. Assuming that the 225 $\mu$ A current source flows only through the internal resistor ( $6R + R = 12.6k\Omega$ ), the cathode voltage of diode D2 is about 2.8V. Since D1 is blocked when the feedback voltage ( $V_{FB}$ ) exceeds 2.8V, the maximum voltage of the cathode of D2 is clamped at this voltage, clamping  $V_{FB}^*$ . Therefore, the peak value of the current through the SenseFET is limited.

**2.2 Leading-Edge Blanking (LEB):** At the instant the internal SenseFET is turned on, a high-current spike usually occurs through the SenseFET, caused by primary-side capacitance and secondary-side rectifier reverse recovery. Excessive voltage across the  $R_{sense}$  resistor would lead to incorrect feedback operation in the current mode VS-PWM control. To counter this effect, the FPS employs a leading-edge blanking (LEB) circuit to inhibit the VS-PWM comparator for a short time ( $t_{LEB}$ ) after the SenseFET is turned on.

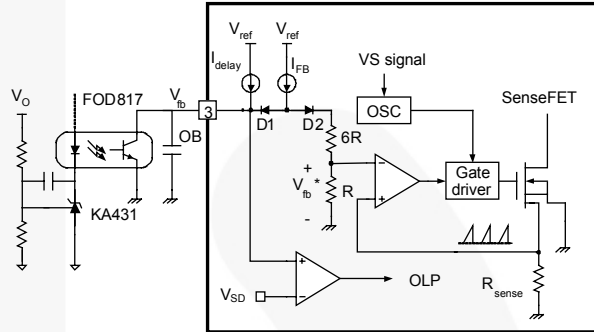


Figure 14. Valley Switching Pulse-Width Modulation (VS-PWM) Circuit

**3. Synchronization:** The FSQ510 (H or M) employs a valley-switching technique to minimize the switching noise and loss. The basic waveforms of the valley switching converter are shown in Figure 15. To minimize the MOSFET switching loss, the MOSFET should be turned on when the drain voltage reaches its minimum value, as shown in Figure 15. The minimum drain voltage is indirectly detected by monitoring the  $V_{CC}$  winding voltage, as shown in Figure 15.

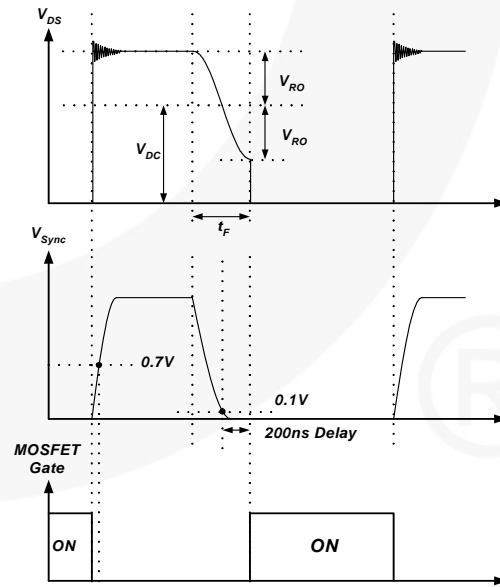
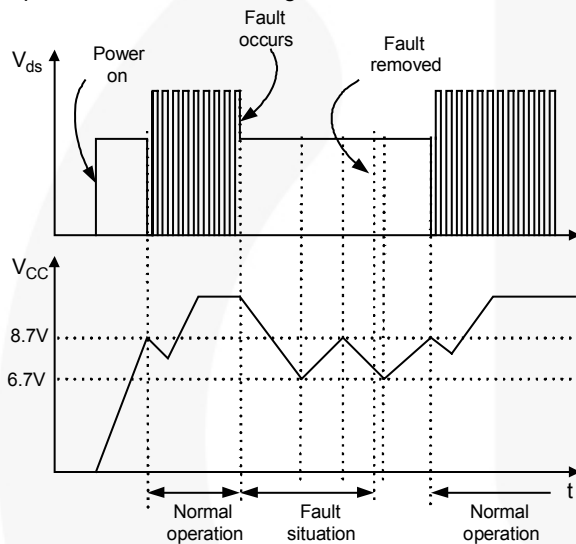


Figure 15. Valley Switching Waveforms

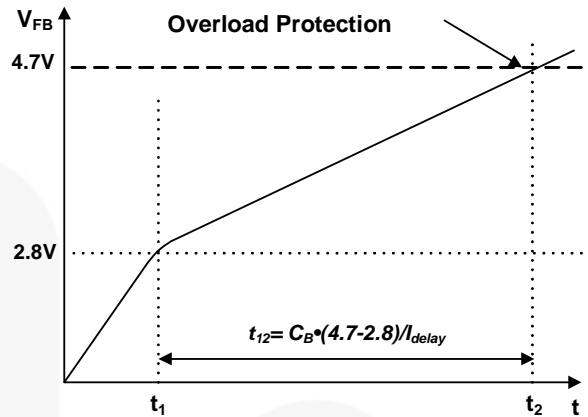
**4. Protection Circuits:** The FSQ510 (H or M) has two self-protective functions, overload protection (OLP) and thermal shutdown (TSD). The protections are implemented as auto-restart mode. Once the fault condition is detected, switching is terminated and the SenseFET remains off. This causes  $V_{CC}$  to fall. When  $V_{CC}$  falls down to the under-voltage lockout (UVLO) stop voltage of 6.7V, the protection is reset and the startup circuit charges the  $V_{CC}$  capacitor. When  $V_{CC}$  reaches the start voltage of 8.7V, the FSQ510 (H or M) resumes normal operation. If the fault condition is not removed, the SenseFET remains off and  $V_{CC}$  drops to stop voltage again. In this manner, the auto-restart can alternately enable and disable the switching of the power SenseFET until the fault condition is eliminated. Because these protection circuits are fully integrated into the IC without external components, reliability is improved without increasing cost.



**Figure 16. Auto Restart Protection Waveforms**

**4.1 Overload Protection (OLP):** Overload is defined as the load current exceeding its normal level due to an unexpected event. In this situation, the protection circuit should trigger to protect the SMPS. However, even when the SMPS is in the normal operation, the overload protection circuit can be triggered during the load transition. To avoid this undesired operation, the overload protection circuit is designed to trigger only after a specified time to determine whether it is a transient situation or a true overload situation. Because of the pulse-by-pulse current limit capability, the maximum peak current through the SenseFET is limited and, therefore, the maximum input power is restricted with a given input voltage. If the output consumes more than this maximum power, the output voltage ( $V_o$ ) decreases below the set voltage. This reduces the current through the opto-coupler LED, which also reduces the opto-coupler transistor current, increasing the feedback voltage ( $V_{FB}$ ). If  $V_{FB}$  exceeds 2.8V, D1 is blocked and the 5 $\mu$ A current source starts to charge  $C_B$  slowly up. In this condition,  $V_{FB}$  continues increasing until it reaches 4.7V, when the switching operation is terminated, as shown in Figure 17. The delay time for shutdown is the time required to charge  $C_B$  from 2.8V to 4.7V with 5 $\mu$ A. A 20 ~ 50ms delay time is typical for

most applications. This protection is implemented in auto-restart mode.

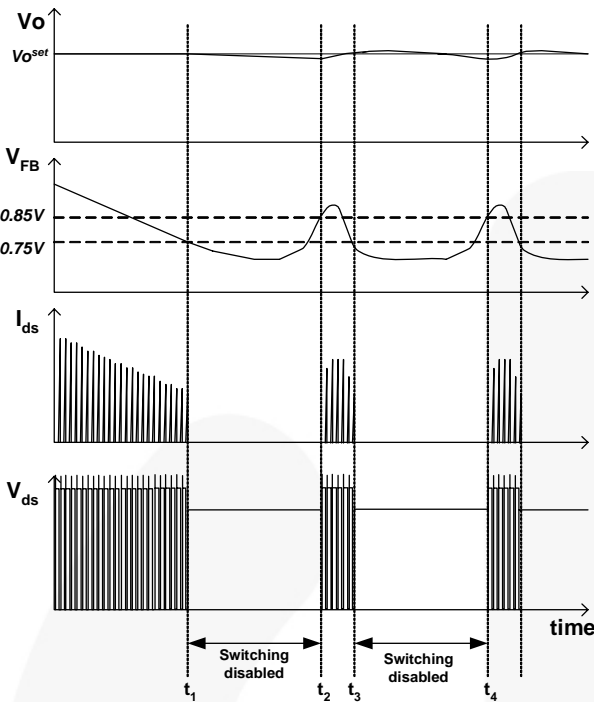


**Figure 17. Overload Protection**

**4.2 Thermal Shutdown (TSD):** The SenseFET and the control IC on a die in one package make it easy for the control IC to detect the abnormal over temperature of the SenseFET. If the temperature exceeds approximately 140°C, the thermal shutdown triggers and the FPS stops operation. The FPS operates in auto-restart mode until the temperature decreases to around 80°C, when normal operation resumes.

**5. Soft-Start:** The FPS has an internal soft-start circuit that increases the VS-PWM comparator inverting input voltage, together with the SenseFET current, slowly after it starts up. The typical soft-start time is 5ms. The pulse width to the power switching device is progressively increased to establish the correct working conditions for transformers, inductors, and capacitors. The voltage on the output capacitors is progressively increased with the intention of smoothly establishing the required output voltage. This helps prevent transformer saturation and reduces stress on the secondary diode during startup.

**6. Burst-Mode Operation:** To minimize power dissipation in standby mode, the FPS enters burst-mode operation. As the load decreases, the feedback voltage decreases. As shown in Figure 18, the device automatically enters burst mode when the feedback voltage drops below  $V_{BURL}$  (750mV). At this point, switching stops and the output voltages start to drop at a rate dependent on standby current load. This causes the feedback voltage to rise. Once it passes  $V_{BURH}$  (850mV), switching resumes. The feedback voltage then falls and the process repeats. Burst mode alternately enables and disables switching of the SenseFET, reducing switching loss in standby mode.



**Figure 18. Burst-Mode Operation**

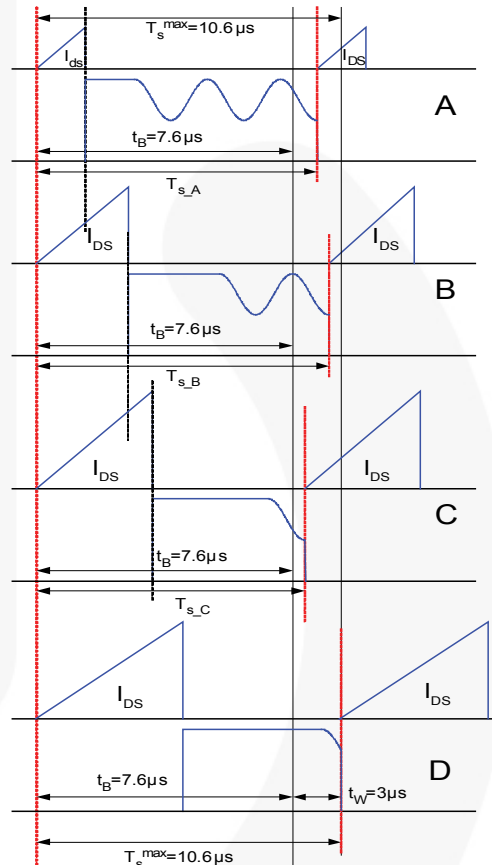
**7. Advanced Valley Switching Operation:** To minimize switching loss and Electromagnetic Interference (EMI), the MOSFET turns on when the drain voltage reaches its minimum value in VS converters. Due to the Discontinuous Conduction Mode (DCM) operation, the feedback voltage is not changed, despite the DC link voltage ripples, if the load condition is not changed. Since the slope of the drain current is changed depending on the DC link voltage, the turn-on duration of MOSFET is variable with the DC link voltage ripples. The switching period is changed continuously with the DC link voltage ripples. Not only the switching at the instant of the minimum drain voltage, but also the continuous change of the switching period, reduces EMI. VS converters inherently scatter the EMI spectrum.

Typical products for VSC turn the MOSFET on when the first valley is detected. In this case, the range of the switching frequency is very wide as a result of the load variations. At a very light-load, for example, the switching frequency can be as high as several hundred kHz. Some products for VSC, such as Fairchild's F5CQ-series, define the turn-on instant of SenseFET change at the first valley into at the second valley, when the load condition decreases under its predetermined level. The range of switching frequency narrows somewhat. For details, consult an F5CQ-series datasheet, such as:

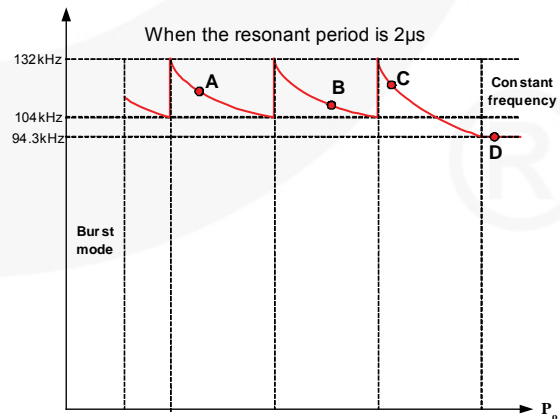
<http://www.fairchildsemi.com/pf/FS/F5CQ1265RT.html>

The range of the switching frequency can be limited tightly in F5CQ-series. Because a kind of blanking time ( $t_B$ ) is adopted, as shown in Figure 19, the switching frequency has minimum and maximum values.

Once the SenseFET is enabled, the next start is prohibited during the blanking time ( $t_B$ ). After the blanking time, the controller finds the first valley within the duration of the valley detection window time ( $t_W$ ) (case A, B, and C). If no valley is found in  $t_W$ , the internal SenseFET is forced to turn on at the end of  $t_W$  (case D). Therefore, F5CQ510, F5CQ510H, and F5CQ510M have minimum switching frequency of 94.3kHz and maximum switching frequency of 132kHz, typically, as shown in Figure 20.

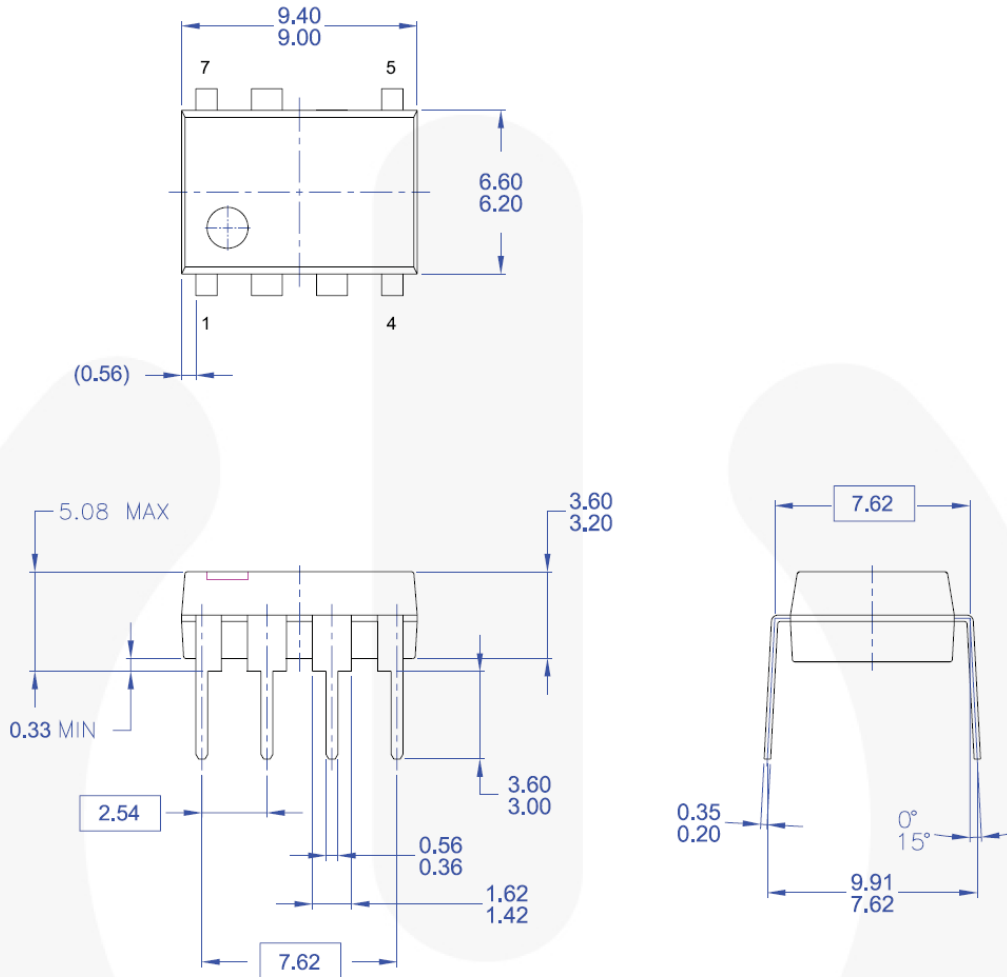


**Figure 19. Advanced VS Operation**



**Figure 20. Switching Frequency Range of the Advanced Valley Switching**

## Package Dimensions



- NOTES: UNLESS OTHERWISE SPECIFIED
- THIS PACKAGE COMPLIES TO JEDEC MS-001, VARIATION BA, EXCEPT FOR TERMINAL COUNT (7 RATHER THAN 8)
  - ALL DIMENSIONS ARE IN MILLIMETERS.
  - DIMENSIONS ARE EXCLUSIVE OF BURRS, MOLD FLASH, AND TIE BAR EXTRUSIONS.
  - DIMENSIONS AND TOLERANCES PER ASME Y14.5M-1994

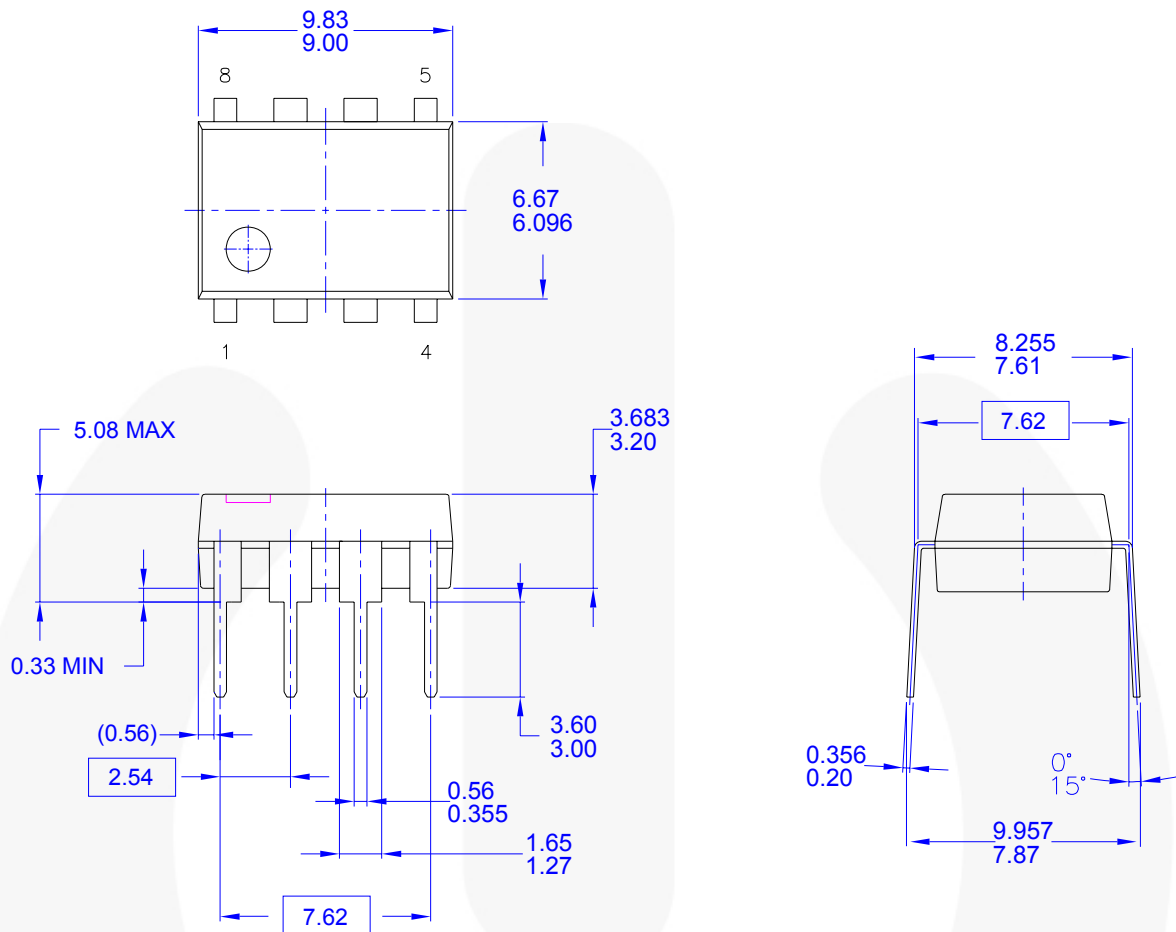
MKT-NA07BrevA

**Figure 21. 7-Lead, Dual In-line Package (DIP)**

Package drawings are provided as a service to customers considering Fairchild components. Drawings may change in any manner without notice. Please note the revision and/or date on the drawing and contact a Fairchild Semiconductor representative to verify or obtain the most recent revision. Package specifications do not expand the terms of Fairchild's worldwide terms and conditions, specifically the warranty therein, which covers Fairchild products.

Always visit Fairchild Semiconductor's online packaging area for the most recent package drawings:  
<http://www.fairchildsemi.com/packaging/>

**Package Dimensions** (Continued)



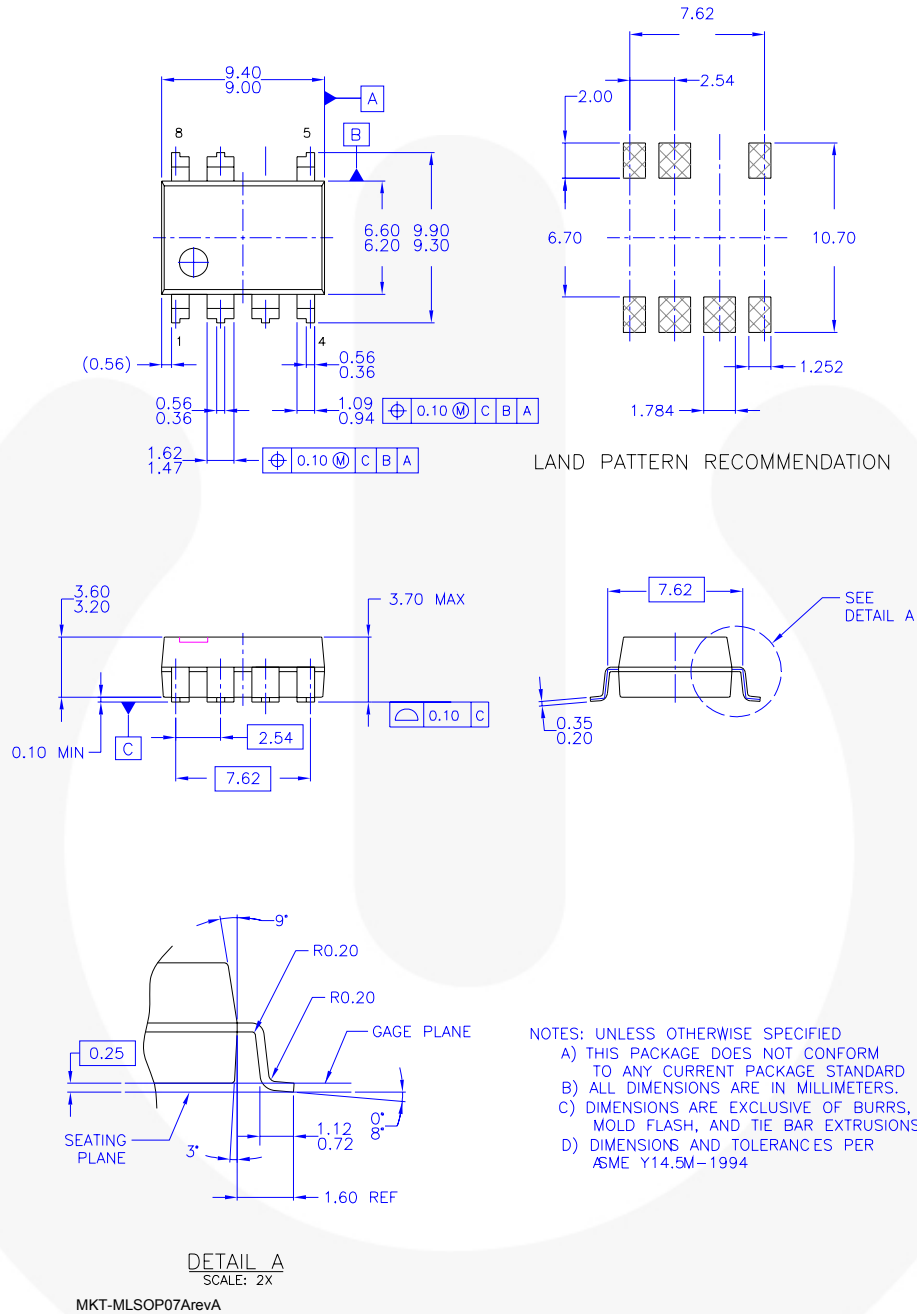
- NOTES: UNLESS OTHERWISE SPECIFIED**
- A) THIS PACKAGE CONFORMS TO JEDEC MS-001 VARIATION BA
  - B) ALL DIMENSIONS ARE IN MILLIMETERS.
  - C) DIMENSIONS ARE EXCLUSIVE OF BURRS, MOLD FLASH, AND TIE BAR EXTRUSIONS.
  - D) DIMENSIONS AND TOLERANCES PER ASME Y14.5M-1994
  - E) DRAWING FILENAME AND REVSION: MKT-N08FRE2.

**Figure 22. 8-Lead, Dual In-line Package (DIP)**

Package drawings are provided as a service to customers considering Fairchild components. Drawings may change in any manner without notice. Please note the revision and/or date on the drawing and contact a Fairchild Semiconductor representative to verify or obtain the most recent revision. Package specifications do not expand the terms of Fairchild's worldwide terms and conditions, specifically the warranty therein, which covers Fairchild products.

Always visit Fairchild Semiconductor's online packaging area for the most recent package drawings:  
<http://www.fairchildsemi.com/packaging/>

**Package Dimensions (Continued)**



**Figure 23. 7-Lead, MLSOP**

Package drawings are provided as a service to customers considering Fairchild components. Drawings may change in any manner without notice. Please note the revision and/or date on the drawing and contact a Fairchild Semiconductor representative to verify or obtain the most recent revision. Package specifications do not expand the terms of Fairchild's worldwide terms and conditions, specifically the warranty therein, which covers Fairchild products.

Always visit Fairchild Semiconductor's online packaging area for the most recent package drawings:  
<http://www.fairchildsemi.com/packaging/>



### TRADEMARKS

The following includes registered and unregistered trademarks and service marks, owned by Fairchild Semiconductor and/or its global subsidiaries, and is not intended to be an exhaustive list of all such trademarks.

Build it Now™	FRFET®	Programmable Active Droop™	
CorePLUS™	Global Power Resource™ SM	QFET®	
CorePOWER™	Green FPS™	QST™	
CROSSVOLT™	Green FPS™ e-Series™	Quiet Series™	
CTL™	GTO™	RapidConfigure™	
Current Transfer Logic™	IntelliMAX™	 ™	
EcoSPARK®	ISOPLANAR™	Saving our world, 1mW/W/kW at a time™	
EfficientMax™	MegaBuck™	SmartMax™	
EZSWTCH™ *	MICROCOUPLER™	SMART START™	
 ™	MicroFET™	SPM®	
 ®	MicroPak™	STEALTH™	
Fairchild®	MillerDrive™	SuperFET™	
Fairchild Semiconductor®	MotionMax™	SuperSOT™L3	
FACT Quiet Series™	Motion-SPM™	SuperSOT™L6	
FACT®	OPTOLOGIC®	SuperSOT™L8	
FAST®	OPTOPLANAR®	SupreMOS™	
FastvCore™	 ™	SyncFET™	
FlashWriter® *	PDP SPM™	 ™	
FPS™	Power-SPM™	The Power Franchise®	
F-PFS™	PowerTrench®		
	PowerXS™		
			
			TinyBoost™
			TinyBuck™
			TinyLogic®
			TINYOPTO™
			TinyPower™
			TinyPWM™
			TinyWire™
			TriFault Detect™
			μSerDes™
			 ™
			UHC®
			Ultra FRFET™
			UniFET™
			VCX™
			VisualMax™
			XS™

\* EZSWTCH™ and FlashWriter® are trademarks of System General Corporation, used under license by Fairchild Semiconductor.

### DISCLAIMER

FAIRCHILD SEMICONDUCTOR RESERVES THE RIGHT TO MAKE CHANGES WITHOUT FURTHER NOTICE TO ANY PRODUCTS HEREIN TO IMPROVE RELIABILITY, FUNCTION, OR DESIGN. FAIRCHILD DOES NOT ASSUME ANY LIABILITY ARISING OUT OF THE APPLICATION OR USE OF ANY PRODUCT OR CIRCUIT DESCRIBED HEREIN; NEITHER DOES IT CONVEY ANY LICENSE UNDER ITS PATENT RIGHTS, NOR THE RIGHTS OF OTHERS. THESE SPECIFICATIONS DO NOT EXPAND THE TERMS OF FAIRCHILD'S WORLDWIDE TERMS AND CONDITIONS, SPECIFICALLY THE WARRANTY THEREIN, WHICH COVERS THESE PRODUCTS.

### LIFE SUPPORT POLICY

FAIRCHILD'S PRODUCTS ARE NOT AUTHORIZED FOR USE AS CRITICAL COMPONENTS IN LIFE SUPPORT DEVICES OR SYSTEMS WITHOUT THE EXPRESS WRITTEN APPROVAL OF FAIRCHILD SEMICONDUCTOR CORPORATION.

As used herein:

1. Life support devices or systems are devices or systems which, (a) are intended for surgical implant into the body or (b) support or sustain life, and (c) whose failure to perform when properly used in accordance with instructions for use provided in the labeling, can be reasonably expected to result in a significant injury of the user.
2. A critical component in any component of a life support, device, or system whose failure to perform can be reasonably expected to cause the failure of the life support device or system, or to affect its safety or effectiveness.

### ANTI-COUNTERFEITING POLICY

Fairchild Semiconductor Corporation's Anti-Counterfeiting Policy. Fairchild's Anti-Counterfeiting Policy is also stated on our external website, [www.fairchildsemi.com](http://www.fairchildsemi.com), under Sales Support.

Counterfeiting of semiconductor parts is a growing problem in the industry. All manufacturers of semiconductor products are experiencing counterfeiting of their parts. Customers who inadvertently purchase counterfeit parts experience many problems such as loss of brand reputation, substandard performance, failed applications, and increased cost of production and manufacturing delays. Fairchild is taking strong measures to protect ourselves and our customers from the proliferation of counterfeit parts. Fairchild strongly encourages customers to purchase Fairchild parts either directly from Fairchild or from Authorized Fairchild Distributors who are listed by country on our web page cited above. Products customers buy either from Fairchild directly or from Authorized Fairchild Distributors are genuine parts, have full traceability, meet Fairchild's quality standards for handling and storage and provide access to Fairchild's full range of up-to-date technical and product information. Fairchild and our Authorized Distributors will stand behind all warranties and will appropriately address any warranty issues that may arise. Fairchild will not provide any warranty coverage or other assistance for parts bought from Unauthorized Sources. Fairchild is committed to combat this global problem and encourage our customers to do their part in stopping this practice by buying direct or from authorized distributors.

### PRODUCT STATUS DEFINITIONS

#### Definition of Terms

Datasheet Identification	Product Status	Definition
Advance Information	Formative / In Design	Datasheet contains the design specifications for product development. Specifications may change in any manner without notice.
Preliminary	First Production	Datasheet contains preliminary data; supplementary data will be published at a later date. Fairchild Semiconductor reserves the right to make changes at any time without notice to improve design.
No Identification Needed	Full Production	Datasheet contains final specifications. Fairchild Semiconductor reserves the right to make changes at any time without notice to improve the design.
Obsolete	Not In Production	Datasheet contains specifications on a product that is discontinued by Fairchild Semiconductor. The datasheet is for reference information only.

Rev. 138



LittleDiode supplies new, hard to find or obsolete electronic components and semiconductors all over the world.

With over two million different components listed you are sure to find the part you need.

Feel free to visit us today at our online store:

[LittleDiode.com](http://LittleDiode.com)

Looking forward to providing you with the best possible service.