HD61203U

(Dot Matrix Liquid Crystal Graphic Display
64-Channel Common Driver)

HITACHI

ADE-207-274(Z)
'99.9
Rev. 0.0

Description

The HD61203U is a common signal driver for dot matrix liquid crystal graphic display systems. It generates the timing signals (switch signal to convert LCD waveform to AC, frame synchronous signal) and supplies them to the column driver to control display. It provides 64 driver output lines and the impedance is low enough to drive a large screen.

As the HD61203U is produced by a CMOS process, it is fit for use in portable battery-driven equipment utilizing the liquid crystal display's low power consumption. The user can easily construct a dot matrix liquid crystal graphic display system by combining the HD61203U and the column (segment) driver HD61202U.

Features

- Dot matrix liquid crystal graphic display common driver with low impedance
- Low impedance: 1.5 k Ω max
- Internal liquid crystal display driver circuit: 64 circuits
- Internal dynamic display timing generator circuit
- Display duty cycle
 - When used with the column driver HD61202U: 1/48, 1/64, 1/96, 1/128
 - When used with the controller HD61830: Selectable out of 1/32 to 1/128
- Low power dissipation: During displays: 5 mW
- Power supplies: V_{CC} : 2.7~5.5V
- Power supply voltage for liquid crystal display drive: 8V to 16V
- CMOS process
- 100-pin plastic QFP, 100-pin plastic TQFP, chip

Ordering Information

Type No.	Package
HD61203UFS	100-pin plastic QFP (FP-100A)
HD61203UTE	100-pin thin plastic QFP (TFP-100B)
HCD61203U	Chip

Pin Arrangement

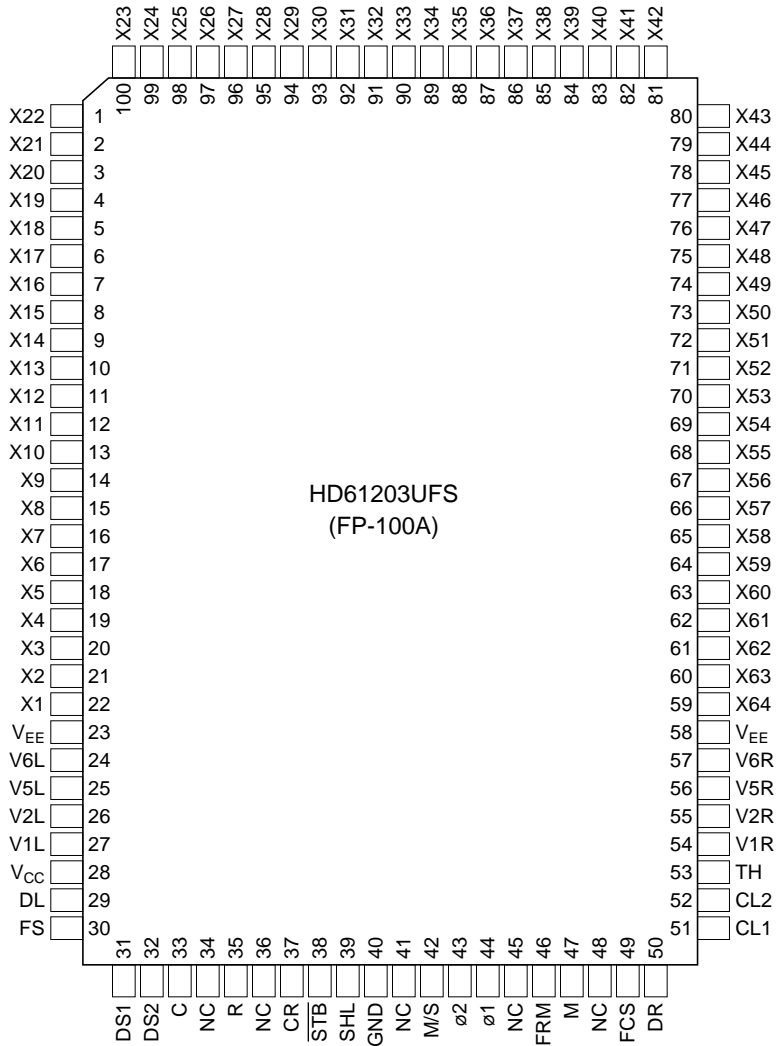

(Top view)

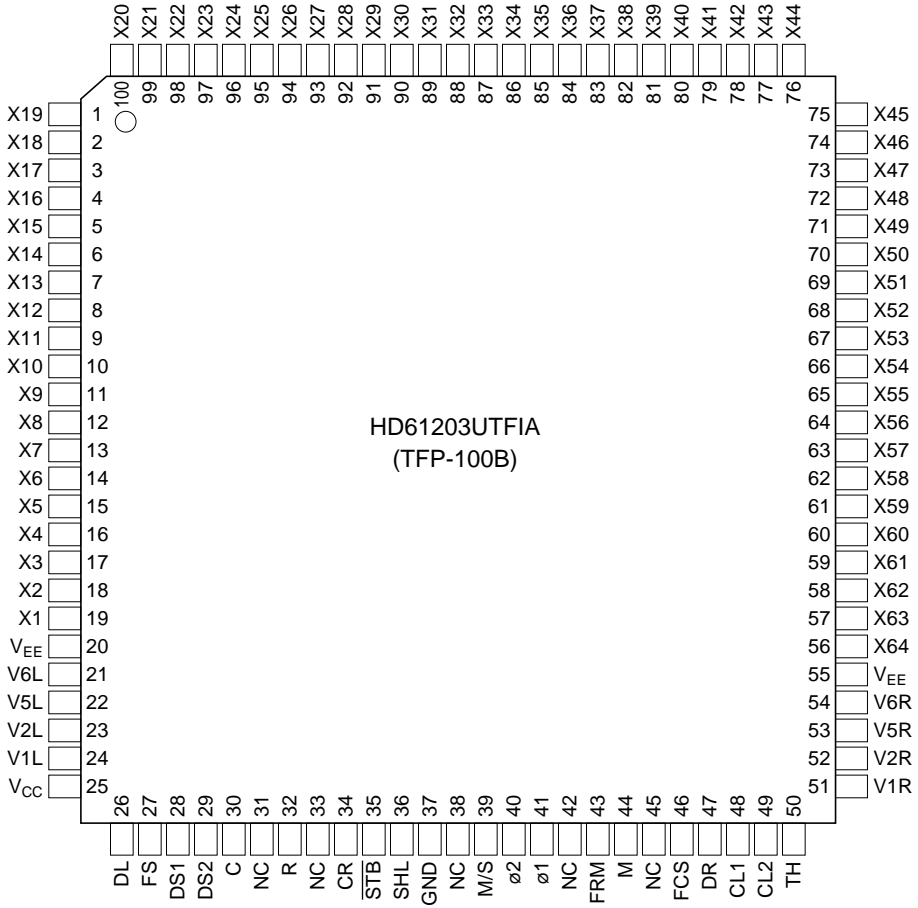

(Top view)

Pad Arrangement

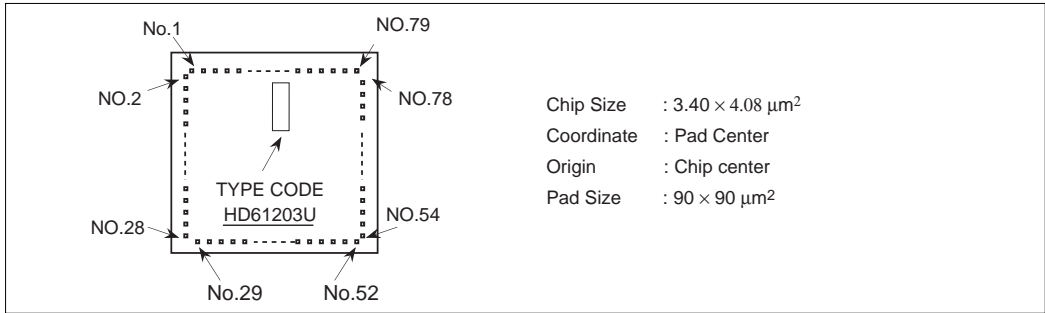

Pad Location Coordinates

		Coordinate						Coordinate			
PAD No.	PAD Name	X	Y	PAD No.	PAD Name	X	Y	PAD No.	PAD Name	X	Y
1	X22	-1479	1853	34		67	X56	1513	203		
2	X21	-1513	1712	35	R	-586	-1828	68	X55	1513	333
3	X20	-1513	1544	36		69	X54	1513	463		
4	X19	-1513	1385	37	CR	-456	-1828	70	X53	1513	593
5	X18	-1513	1238	38		71	X52	1513	723		
6	X17	-1513	1091	39	SHL	-196	-1828	72	X51	1513	853
7	X16	-1513	952	40	GND	-65	-1828	73	X50	1513	983
8	X15	-1513	822	41		74	X49	1513	1122		
9	X14	-1513	692	42	M/S	65	-1828	75	X48	1513	1261
10	X13	-1513	562	43	PHI2	195	-1828	76	X47	1513	1399
11	X12	-1513	432	44	PHI1	325	-1828	77	X46	1513	1546
12	X11	-1513	302	45		78	X45	1513	1693		
13	X10	-1513	172	46	FRM	455	-1828	79	X44	1470	1853
14	X9	-1513	42	47	M	585	-1828	80	X43	1304	1853
15	X8	-1513	-88	48		81	X42	1170	1853		
16	X7	-1513	-218	49	FCS	715	-1828	82	X41	1040	1853
17	X6	-1513	-349	50	DR	853	-1828	83	X40	910	1853
18	X5	-1513	-479	51		84	X39	779	1853		
19	X4	-1513	-609	52	CL2	1407	-1828	85	X38	649	1853
20	X3	-1513	-739	53		86	X37	519	1853		
21	X2	-1513	-869	54	V1R	1513	-1522	87	X36	389	1853
22	X1	-1513	-999	55	V2R	1513	-1374	88	X35	259	1853
23	V _{EE1}	-1513	-1129	56	V5R	1513	-1236	89	X34	129	1853
24	V6L	-1513	-1259	57	V6R	1513	-1097	90	X33	-1	1853
25	V5L	-1513	-1389	58	V _{EE2}	1513	-967	91	X32	-131	1853
26	V2L	-1513	-1527	59	X64	1513	-837	92	X31	-261	1853
27	V1L	-1513	-1665	60	X63	1513	-707	93	X30	-391	1853
28	V _{CC}	-1513	-1821	61	X62	1513	-577	94	X29	-521	1853
29	DL	-1375	-1853	62	X61	1513	-447	95	X28	-651	1853
30	FS	-1213	-1853	63	X60	1513	-317	96	X27	-781	1853
31	DS1	-976	-1828	64	X59	1513	-187	97	X26	-911	1853
32	DS2	-846	-1828	65	X58	1513	-57	98	X25	-1041	1853
33	C	-716	-1828	66	X57	1513	73	99	X24	-1171	1853
								100	X23	-1301	1853

Block Diagram

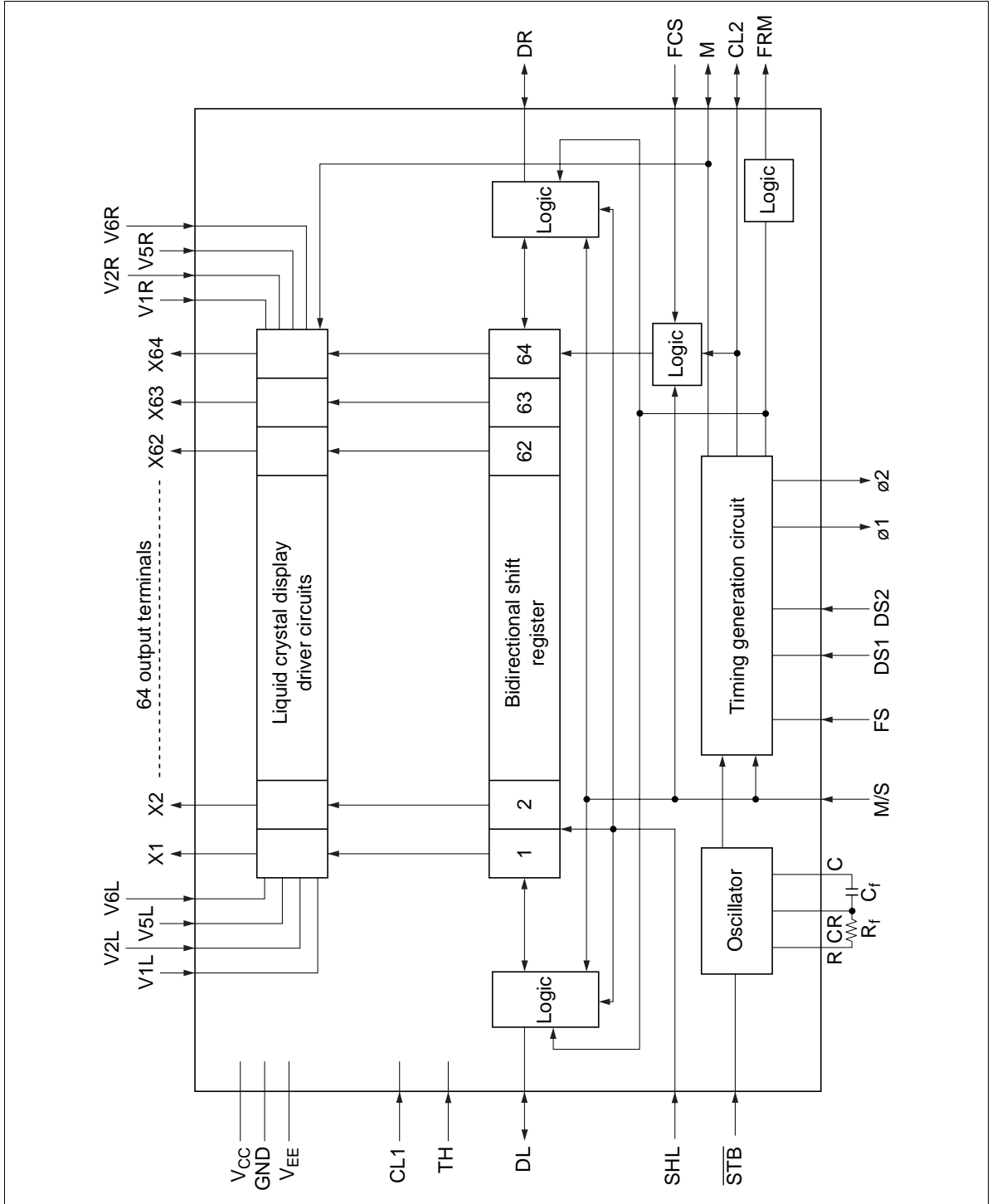

Block Functions

Oscillator

The CR oscillator generates display timing signals and operating clocks for the HD61202U. It is required when the HD61203U is used with the HD61202U. An oscillation resistor R_f and an oscillation capacitor C_f are attached as shown in Figure 1. When using an external clock, input the clock into terminal CR and don't connect any lines to terminals R and C.

The oscillator is not required when the HD61203U is used with the HD61830. Then, connect terminal CR to the high level and don't connect any lines to terminals R and C (Figure 2).

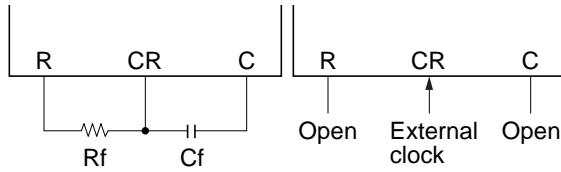

Figure 1 Oscillator Connection with HD61202U

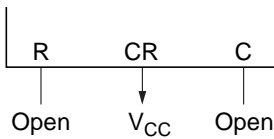

Figure 2 Oscillator Connection with HD61830

Timing Generator Circuit

The timing generator circuit generates display timing and operating clock for the HD61202U. This circuit is required when the HD61203U is used with the HD61202U. Connect terminal M/S to high level (master mode). It is not necessary when the display timing signal is supplied from other circuits, for example, from HD61830. In this case connect the terminals FS, DS1, and DS2 to high level and M/S to low level (slave mode).

Bidirectional Shift Register

A 64-bit bidirectional shift register. The data is shifted from DL to DR when SHL is at high level and from DR to DL when SHL is at low level. In this case, CL2 is used as shift clock. The lowest order bit of the bidirectional shift register, which is on the DL side, corresponds to X1 and the highest order bit on the DR side corresponds to X64.

Liquid Crystal Display Driver Circuit

The combination of the data from the shift register with the M signal allows one of the four liquid crystal display driver levels V1, V2, V5 and V6 to be transferred to the output terminals (Table 1).

Table 1 Output Levels

Data from the Shift Register	M	Output Level
1	1	V2
0	1	V6
1	0	V1
0	0	V5

HD61203U Terminal Functions

Terminal Name	Number of Terminals	I/O	Connected to	Functions
V _{CC}	1		Power supply	V _{CC} -GND: Power supply for internal logic.
GND	1			V _{CC} -V _{EE} : Power supply for driver circuit logic.
V _{EE}	2			
V1L, V2L V5L, V6L V1R, V2R V5R, V6R	8		Power supply	Liquid crystal display driver level power supply. V1L (V1R), V2L (V2R): Selected level V5L (V5R), V6L (V6R): Non-selected level Voltages of the level power supplies connected to V1L and V1R should be the same. (This applies to the combination of V2L & V2R, V5L & V5R and V6L & V6R respectively.)
M/S	1	I	V _{CC} or GND	<p>Selects master/slave.</p> <ul style="list-style-type: none"> M/S = V_{CC}: Master mode When the HD61203U is used with the HD61202U, timing generation circuit operates to supply display timing signals and operation clock to the HD61202U. Each of I/O common terminals DL, DR, CL2, and M is in the output state. M/S = GND: Slave mode The timing operation circuit stops operating. The HD61203U is used in this mode when combined with the HD61830. Even if combined with the HD61202U, this mode is used when display timing signals (M, data, CL2, etc.) are supplied by another HD61203U in the master mode. Terminals M and CL2 are in the input state. <p>When SHL is V_{CC}, DL is in the input state and DR is in the output state.</p> <p>When SHL is GND, DL is in the output state and DR is in the input state.</p>
FCS	1	I	V _{CC} or GND	<p>Selects shift clock phase.</p> <ul style="list-style-type: none"> FCS = V_{CC} Shift register operates at the rising edge of CL2. Select this condition when HD61203U is used with HD61202U or when MA of the HD61830 connects to CL2 in combination with the HD61830. FCS = GND Shift register operates at the fall of CL2. Select this condition when CL1 of HD61830 connects to CL2 in combination with the HD61830.

HD61203U

Terminal Name	Number of Terminals	I/O	Connected to	Functions															
FS	1	I	V _{CC} or GND	<p>Selects frequency.</p> <p>When the frame frequency is 70 Hz, the oscillation frequency should be:</p> $f_{OSC} = 430 \text{ kHz at FCS} = V_{CC}$ $f_{OSC} = 215 \text{ kHz at FCS} = \text{GND}$ <p>This terminal is active only in the master mode. Connect it to V_{CC} in the slave mode.</p>															
DS1, DS2	2	I	V _{CC} or GND	<p>Selects display duty factor.</p> <table border="1"> <thead> <tr> <th>Display Duty Factor</th> <th>1/48</th> <th>1/64</th> <th>1/96</th> <th>1/128</th> </tr> </thead> <tbody> <tr> <td>DS1</td> <td>GND</td> <td>GND</td> <td>V_{CC}</td> <td>V_{CC}</td> </tr> <tr> <td>DS2</td> <td>GND</td> <td>V_{CC}</td> <td>GND</td> <td>V_{CC}</td> </tr> </tbody> </table> <p>These terminals are valid only in the master mode. Connect them to V_{CC} in the slave mode.</p>	Display Duty Factor	1/48	1/64	1/96	1/128	DS1	GND	GND	V _{CC}	V _{CC}	DS2	GND	V _{CC}	GND	V _{CC}
Display Duty Factor	1/48	1/64	1/96	1/128															
DS1	GND	GND	V _{CC}	V _{CC}															
DS2	GND	V _{CC}	GND	V _{CC}															
$\overline{\text{STB}}$	1	I	V _{CC} or GND	Input terminal for testing															
TH	1			Connect to $\overline{\text{STB}}$ V _{CC} .															
CL1	1			Connect TH and CL1 to GND.															
CR, R, C	3			<p>Oscillator</p> <p>In the master mode, use these terminals as shown below:</p> <div style="display: flex; justify-content: space-around;"> <div style="text-align: center;"> <p>Internal oscillation</p> </div> <div style="text-align: center;"> <p>External clock</p> </div> </div> <p>In the slave mode, stop the oscillator as shown below:</p> <div style="text-align: center;"> </div>															
ø1, ø2	2	O	HD61202U	<p>Operating clock output terminals for the HD61202U</p> <ul style="list-style-type: none"> Master mode Connect these terminals to terminals ø1 and ø2 of the HD61202U respectively. Slave mode Don't connect any lines to these terminals. 															

Terminal Name	Number of Terminals	I/O	Connected to	Functions																				
FRM	1	O	HD61202U	Frame signal <ul style="list-style-type: none"> • Master mode Connect this terminal to terminal FRM of the HD61202U. • Slave mode Don't connect any lines to this terminal. 																				
M	1	I/O	MB of HD61830 or M of HD61202U	Signal to convert LCD driver signal into AC <ul style="list-style-type: none"> • Master mode: Output terminal Connect this terminal to terminal M of the HD61202U. • Slave mode: Input terminal Connect this terminal to terminal MB of the HD61830. 																				
CL2	1	I/O	CL1 or MA of HD61830 or CL of HD61202U	Shift clock <ul style="list-style-type: none"> • Master mode: Output terminal Connect this terminal to terminal CL of the HD61202U. • Slave mode: Input terminal Connect this terminal to terminal CL1 or MA of the HD61830. 																				
DL, DR	2	I/O	Open or FLM of HD61830	Data I/O terminals of bidirectional shift register DL corresponds to X1's side and DR to X64's side. <ul style="list-style-type: none"> • Master mode Output common scanning signal. Don't connect any lines to these terminals normally. • Slave mode Connect terminal FLM of the HD61830 to DL (when SHL = V_{cc}) or DR (when SHL = GND). <table border="1" style="width: 100%; border-collapse: collapse; margin-top: 5px;"> <thead> <tr> <th style="text-align: left;">M/S</th> <th colspan="2" style="text-align: center;">V_{cc}</th> <th colspan="2" style="text-align: center;">GND</th> </tr> <tr> <th style="text-align: left;">SHL</th> <th style="text-align: center;">V_{cc}</th> <th style="text-align: center;">GND</th> <th style="text-align: center;">V_{cc}</th> <th style="text-align: center;">GND</th> </tr> </thead> <tbody> <tr> <td>DL</td> <td style="text-align: center;">Output</td> <td style="text-align: center;">Output</td> <td style="text-align: center;">Input</td> <td style="text-align: center;">Output</td> </tr> <tr> <td>DR</td> <td style="text-align: center;">Output</td> <td style="text-align: center;">Output</td> <td style="text-align: center;">Output</td> <td style="text-align: center;">Input</td> </tr> </tbody> </table>	M/S	V _{cc}		GND		SHL	V _{cc}	GND	V _{cc}	GND	DL	Output	Output	Input	Output	DR	Output	Output	Output	Input
M/S	V _{cc}		GND																					
SHL	V _{cc}	GND	V _{cc}	GND																				
DL	Output	Output	Input	Output																				
DR	Output	Output	Output	Input																				
NC	5		Open	Not used. Don't connect any lines to this terminal.																				
SHL	1	I	V _{cc} or GND	Selects shift direction of bidirectional shift register. <table border="1" style="width: 100%; border-collapse: collapse; margin-top: 5px;"> <thead> <tr> <th style="text-align: left;">SHL</th> <th style="text-align: left;">Shift Direction</th> <th style="text-align: left;">Common Scanning Direction</th> </tr> </thead> <tbody> <tr> <td style="text-align: center;">V_{cc}</td> <td style="text-align: center;">DL → DR</td> <td style="text-align: center;">X1 → X64</td> </tr> <tr> <td style="text-align: center;">GND</td> <td style="text-align: center;">DL ← DR</td> <td style="text-align: center;">X1 ← X64</td> </tr> </tbody> </table>	SHL	Shift Direction	Common Scanning Direction	V _{cc}	DL → DR	X1 → X64	GND	DL ← DR	X1 ← X64											
SHL	Shift Direction	Common Scanning Direction																						
V _{cc}	DL → DR	X1 → X64																						
GND	DL ← DR	X1 ← X64																						

HD61203U

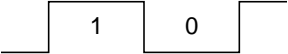
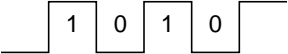
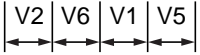
Terminal Name	Number of Terminals	I/O	Connected to	Functions
X1-X64	64	O	Liquid crystal display	Liquid crystal display driver output Output one of the four liquid crystal display driver M  Data  Output level  When SHL is V_{CC} , X1 corresponds to COM1 and X64 corresponds to COM64. When SHL is GND, X64 corresponds to COM1 and X1 corresponds to COM64.

Example of Application

HD61203U Connection List

	M/S	TH	CL1	FCS	FS	DS1	DS2	STB	CR	R	C	ø1	ø2	FRM	M	CL2	SHL	DL	DR	X1-X64
A	L	L	L	L	H	H	H	H	H	—	—	—	—	—	From MB of HD61830	From CL1 of HD61830	H	From FLM of HD61830	—	COM1-COM64
B	L	L	L	H	H	H	H	H	H	—	—	—	—	—	From MB of HD61830	From MA of HD61830	H	From FLM of HD61830 To DL/DR of HD61203U No. 2	From FLM of HD61830 To DL/DR of HD61203U No. 2	COM64-COM1 COM1-COM64
C	L	L	L	H	H	H	H	H	H	—	—	—	—	—	From MB of HD61830	From MA of HD61830	H	From DL/DR of HD61203U No. 1	—	COM65-COM128
D	H	L	L	H	L	L	L	H	Rf	Rf	Cf	To ø1 of HD61202U or L	To ø2 of HD61202U	—	To M of HD61202U	To CL of HD61202U	H	—	—	COM1-COM64
E	H	L	L	H	L	L	L	H	Rf	Rf	Cf	To ø1 of HD61202U or L	To ø2 of HD61202U	To FRM of HD61202U	To M of HD61202U	To CL of HD61202U To CL2 of HD61203U	H	—	To DL/DR of HD61203U No. 2	COM1-COM64
F	L	L	L	H	H	H	H	H	H	—	—	—	—	—	From M of HD61203U No. 1	From CL2 of HD61203U No. 1	H	From DL/DR of HD61203U No. 1	—	COM1-COM64
																	L	—	From DL/DR of HD61203U No. 1	COM64-COM1

Notes: H: V_{CC} } Fixed
L: GND }
"_" means "open".
Rf: Oscillation resistor
Cf: Oscillation capacitor

Outline of HD61203U System Configuration

Use with HD61830

1. When display duty ratio of LCD is 1/64

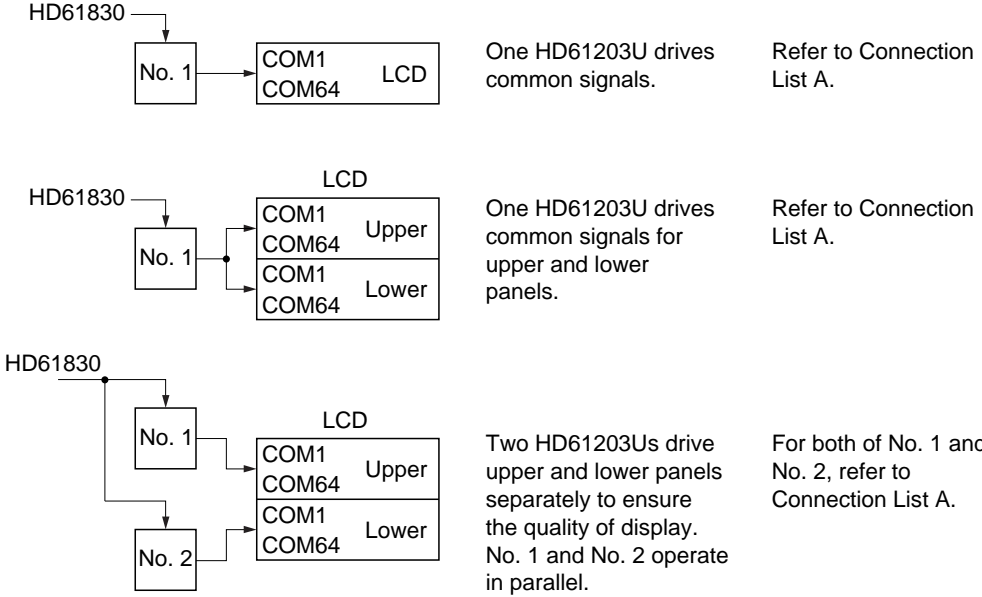

One HD61203U drives common signals.

Refer to Connection List A.

One HD61203U drives common signals for upper and lower panels.

Refer to Connection List A.

Two HD61203Us drive upper and lower panels separately to ensure the quality of display. No. 1 and No. 2 operate in parallel.

For both of No. 1 and No. 2, refer to Connection List A.

2. When display duty ratio of LCD is from 1/65 to 1/128

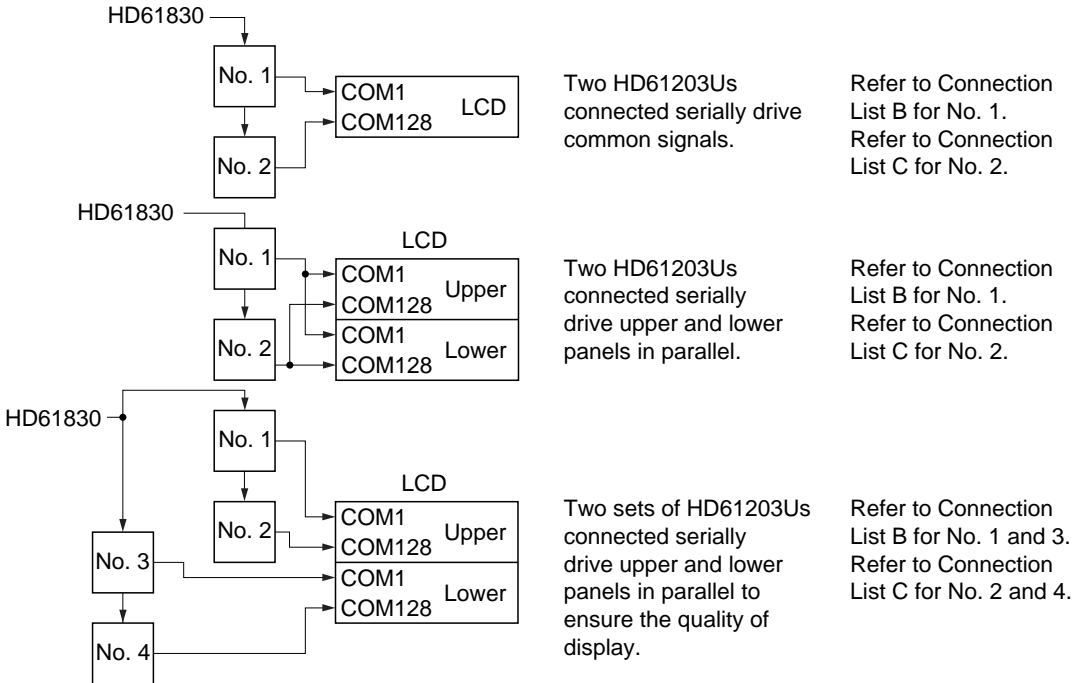

Two HD61203Us connected serially drive common signals.

Refer to Connection List B for No. 1. Refer to Connection List C for No. 2.

Two HD61203Us connected serially drive upper and lower panels in parallel.

Refer to Connection List B for No. 1. Refer to Connection List C for No. 2.

Two sets of HD61203Us connected serially drive upper and lower panels in parallel to ensure the quality of display.

Refer to Connection List B for No. 1 and 3. Refer to Connection List C for No. 2 and 4.

Use with HD61202 (1/64 Duty Ratio)

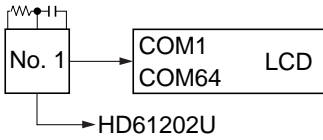

One HD61203U drives common signals and supplies timing signals to the HD61202Us.

Refer to Connection List D.

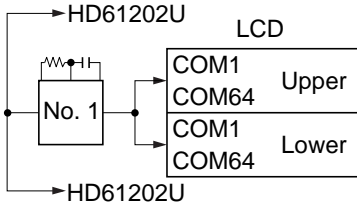

One HD61203U drives upper and lower panels and supplies timing signals to the HD61202Us.

Refer to Connection List D.

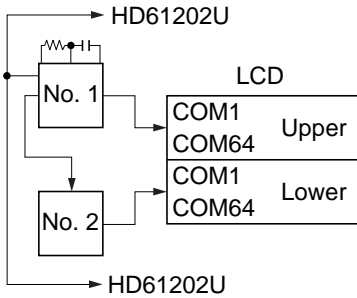

Two HD61203Us drive upper and lower panels in parallel to ensure the quality of display. No. 1 supplies timing signals to No. 2 and the HD61202Us.

Refer to Connection List E for No. 1. Refer to Connection List F for No. 2.

Connection Example 1

Use with HD61202U (RAM Type Segment Driver)

1. 1/64 duty ratio (see Connection List D)

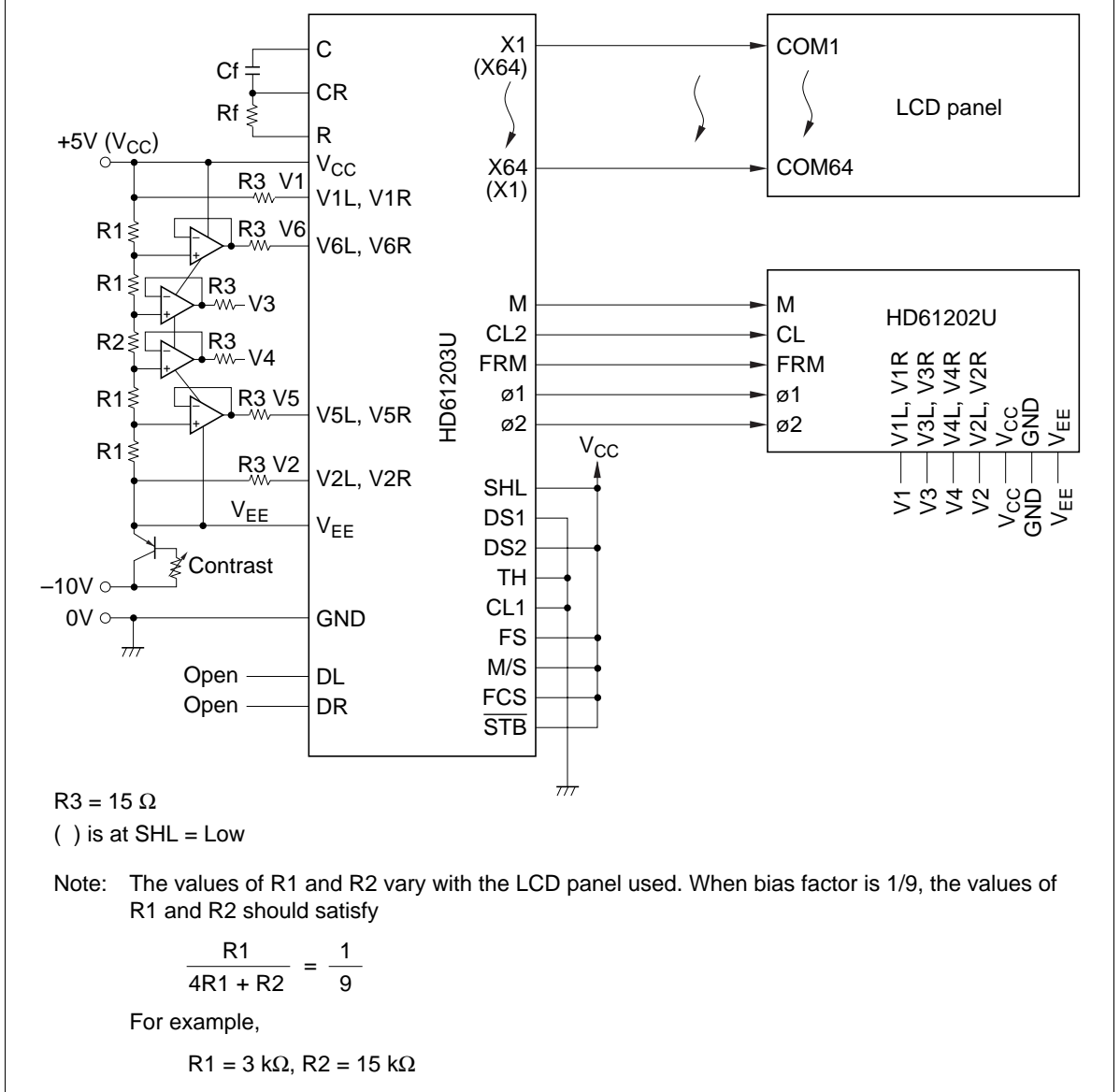

Figure 3 Example 1

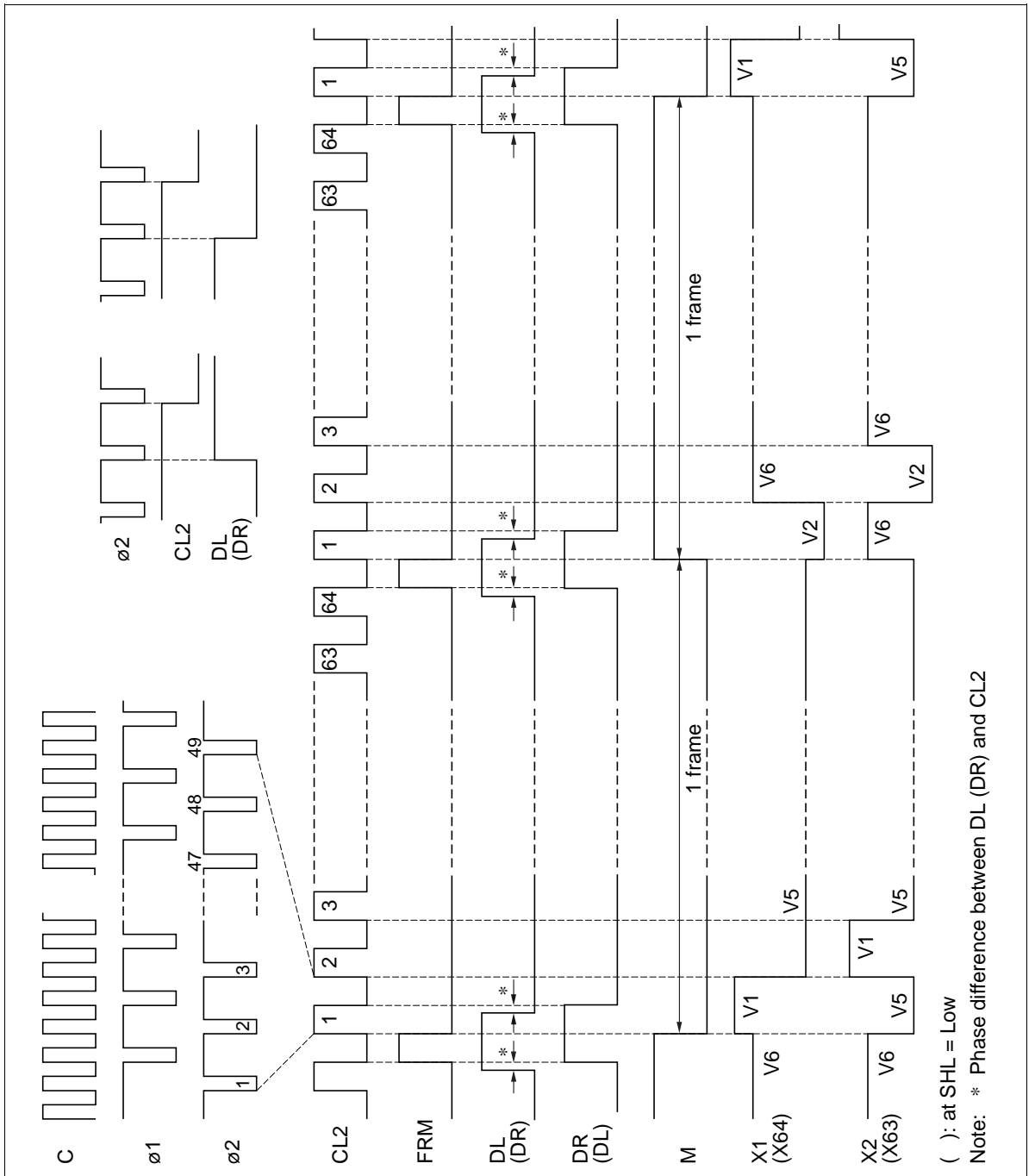

Figure 4 Example 1 Waveform (RAM Type, 1/64 Duty Cycle)

Connection Example 2

Use with HD61830 (Display Controller)

- 1/64 duty ratio (see Connection List A)

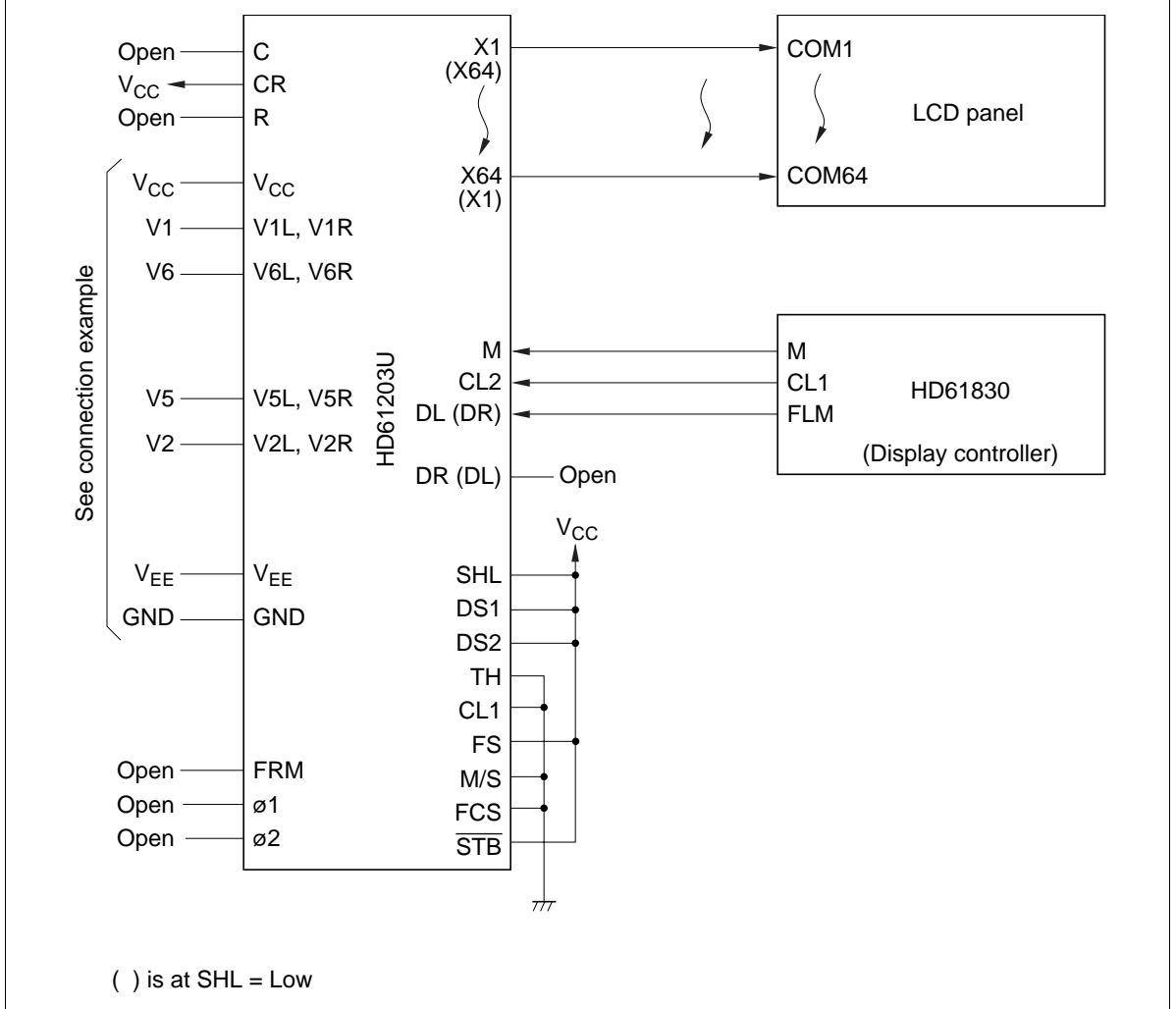

Figure 5 Example 2 (1/64 Duty Ratio)

2. 1/100 duty ratio (see Connection List B, C)

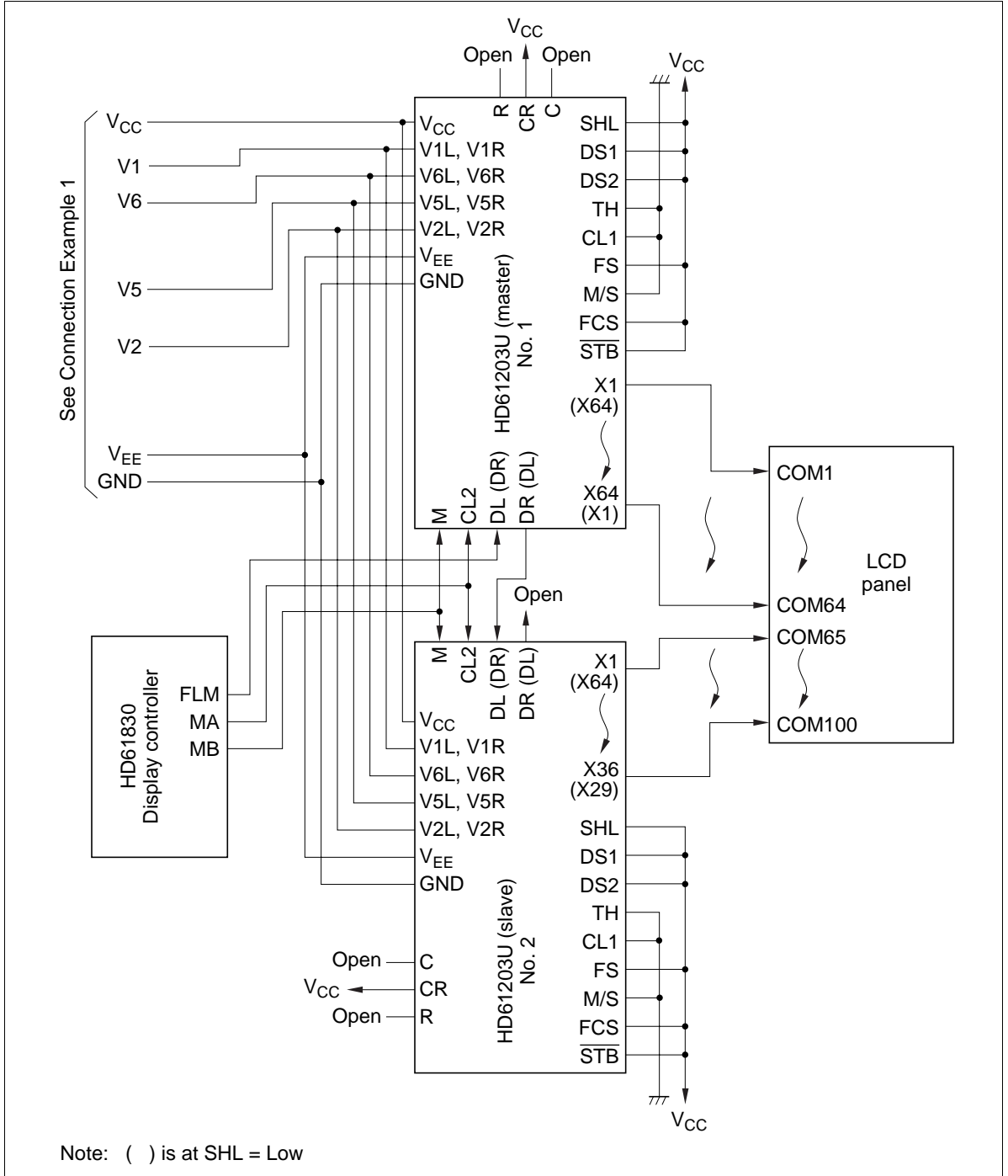

Figure 7 Example 2 (1/100 Duty Ratio)

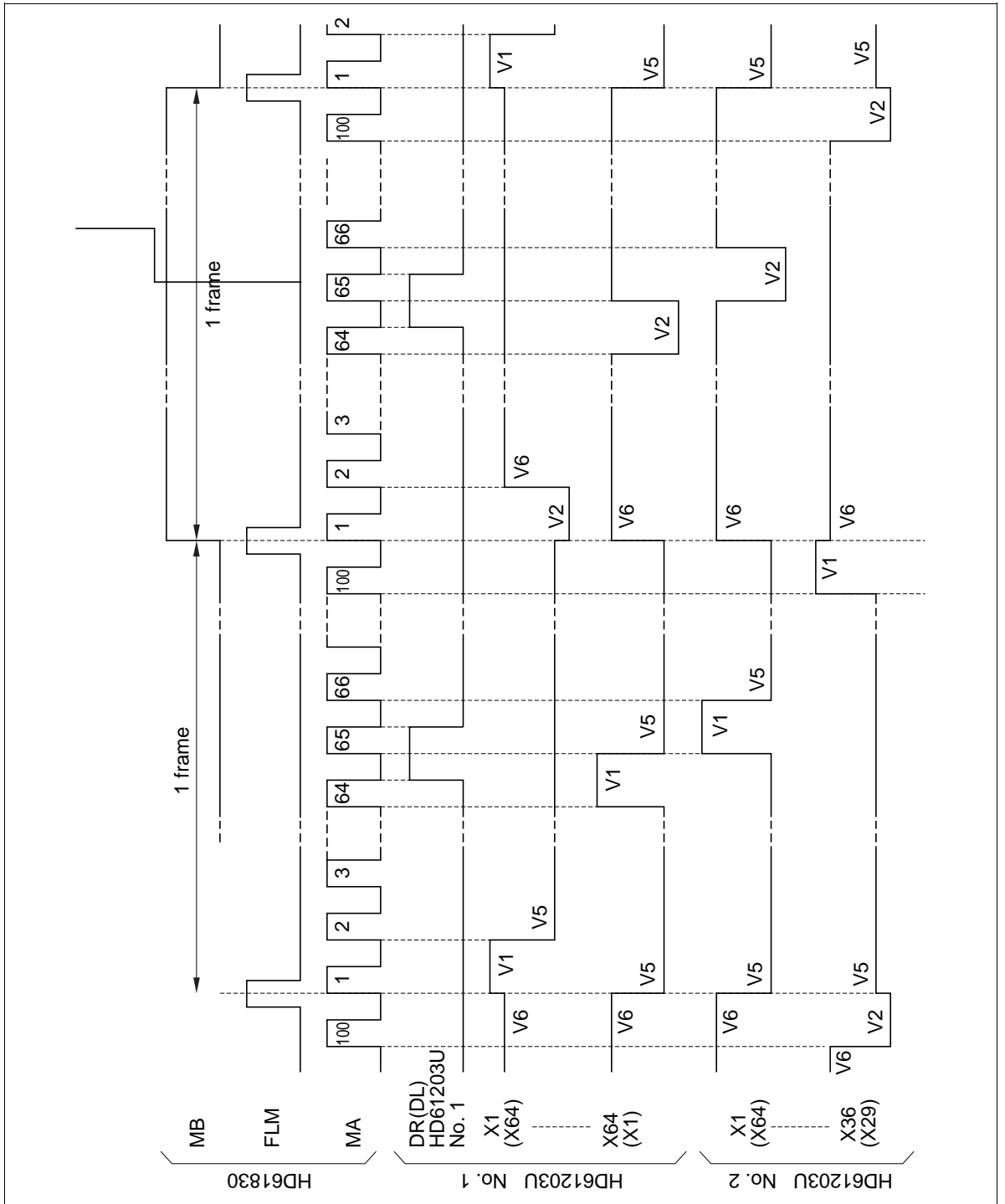

Figure 8 Example 2 Waveform (1/100 Duty Ratio)

Absolute Maximum Ratings

Item	Symbol	Limit	Unit	Notes
Power supply voltage (1)	V_{CC}	-0.3 to +7.0	V	2
Power supply voltage (2)	V_{EE}	$V_{CC} - 17.0$ to $V_{CC} + 0.3$	V	5
Terminal voltage (1)	V_{T1}	-0.3 to $V_{CC} + 0.3$	V	2, 3
Terminal voltage (2)	V_{T2}	$V_{EE} - 0.3$ to $V_{CC} + 0.3$	V	4, 5
Operating temperature	T_{opr}	-30 to +75	°C	
Storage temperature	T_{stg}	-55 to +125	°C	

Notes: 1. If LSIs are used beyond absolute maximum ratings, they may be permanently destroyed. We strongly recommend you to use the LSI within electrical characteristic limits for normal operation, because use beyond these conditions will cause malfunction and poor reliability.

2. Based on GND = 0V.

3. Applies to input terminals (except V1L, V1R, V2L, V2R, V5L, V5R, V6L, and V6R) and I/O terminals at high impedance.

4. Applies to V1L, V1R, V2L, V2R, V5L, V5R, V6L, and V6R.

5. Apply the same value of voltages to V1L and V1R, V2L and V2R, V5L and V5R, V6L and V6R, V_{EE} (23 pin) and V_{EE} (58 pin) respectively.

$$\text{Maintain } V_{CC} \geq V1L = V1R \geq V6L = V6R \geq V5L = V5R \geq V2L = V2R \geq V_{EE}$$

Electrical Characteristics

DC Characteristics ($V_{CC} = 2.7V$ to $5.5V$, $GND = 0V$, $V_{CC} - V_{EE} = 8.0$ to $16.0V$, $T_a = -30$ to $+75^{\circ}C$)^{*14}

Test Item	Symbol	Specifications			Unit	Test Conditions	Notes
		Min	Typ	Max			
Input high voltage	V_{IH}	$0.7 \times V_{CC}$	—	V_{CC}	V		1
Input low voltage	V_{IL}	GND	—	$0.3 \times V_{CC}$	V		1
Output high voltage	V_{OH}	$V_{CC} - 0.4$	—	—	V	$I_{OH} = -0.4$ mA	2
Output low voltage	V_{OL}	—	—	0.4	V	$I_{OL} = 0.4$ mA	2
$V_i - X_j$ on resistance	R_{ON}	—	—	1.5	k Ω	$V_{CC} - V_{EE} = 10V$ Load current ± 150 μA	13
Input leakage current	I_{IL1}	-1.0	—	1.0	μA	$V_{in} = 0$ to V_{CC}	3
Input leakage current	I_{IL2}	-2.0	—	2.0	μA	$V_{in} = V_{EE}$ to V_{CC}	4
Operating frequency	f_{opr1}	50	—	600	kHz	In master mode external clock operation	5
Operating frequency	f_{opr2}	0.5	—	1500	kHz	In slave mode shift 6 register	6
Oscillation frequency	f_{osc}	315	450	585	kHz	$C_f = 20$ pF $\pm 5\%$ $R_f = 39$ k Ω $\pm 2\%$	7, 12
Dissipation current (1)	I_{GG1}	—	—	1.0	mA	In master mode 1/128 duty cycle $C_f = 20$ pF $R_f = 39$ k Ω	8, 9
Dissipation current (2)	I_{GG2}	—	—	200	μA	In slave mode 1/128 duty cycle	8, 10
Dissipation current	I_{EE}	—	—	100	μA	In master mode 1/128 duty cycle	8, 11

- Notes: 1. Applies to input terminals FS, DS1, DS2, CR, SHL, M/S, and FCS and I/O terminals DL, M, DR and CL2 in the input state.
 2. Applies to output terminals, $\emptyset 1$, $\emptyset 2$, and FRM and I/O common terminals DL, M, DR, and CL2 in the output status.
 3. Applies to input terminals FS, DS1, DS2, CR, \overline{STB} , SHL, M/S, FCS, CL1, and TH, I/O terminals DL, M, DR, and CL2 in the input state and NC terminals.
 4. Applies to V1L, V1R, V2L, V2R, V5L, V5R, V6L, and V6R. Don't connect any lines to X1 to X64.

5. External clock is as follows.

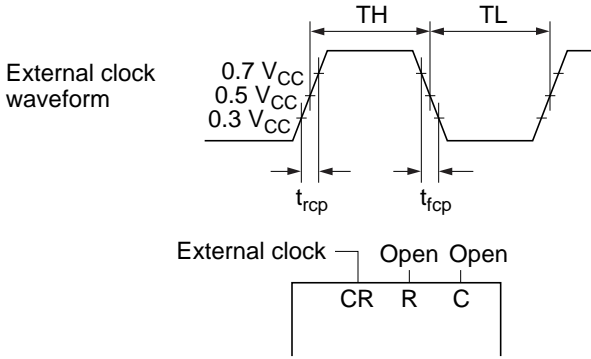

$$\text{Duty cycle} = \frac{\text{TH}}{\text{TH} + \text{TL}} \times 100\%$$

	Min	Typ	Max	Unit
Duty cycle	45	50	55	%
t_{rcp}	—	—	50	ns
t_{fcp}	—	—	50	ns

- 6. Applies to the shift register in the slave mode. For details, refer to AC characteristics.
- 7. Connect oscillation resistor (Rf) and oscillation capacitance (Cf) as shown in this figure. Oscillation frequency (f_{osc}) is twice as much as the frequency ($f\phi$) at $\phi 1$ or $\phi 2$.

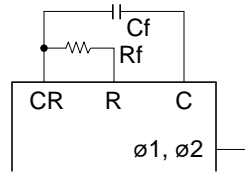

$$C_f = 20 \text{ pF}$$

$$R_f = 39 \text{ k}\Omega \quad f_{osc} = 2 \times f\phi$$

- 8. No lines are connected to output terminals and current flowing through the input circuit is excluded. This value is specified at $V_{IH} = V_{CC}$ and $V_{IL} = \text{GND}$.
- 9. This value is specified for current flowing through GND in the following conditions: Internal oscillation circuit is used. Each terminal of DS1, DS2, FS, SHL, M/S, $\overline{\text{STB}}$, and FCS is connected to V_{CC} and each of CL1 and TH to GND. Oscillator is set as/ described in note 7.
- 10. This value is specified for current flowing through GND under the following conditions: Each terminals of DS1, DS2, FS, SHL, $\overline{\text{STB}}$, FCS and CR is connected to V_{CC} , CL1, TH, and M/S to GND and the terminals CL2, M, and DL are respectively connected to terminals CL2, M, and DL of the HD61203U under the condition described in note 9.
- 11. This value is specified for current flowing through V_{EE} under the condition described in note 9. Don't connect any lines to terminal V.
- 12. This figure shows a typical relation among oscillation frequency, Rf and Cf. Oscillation frequency may vary with the mounting conditions.

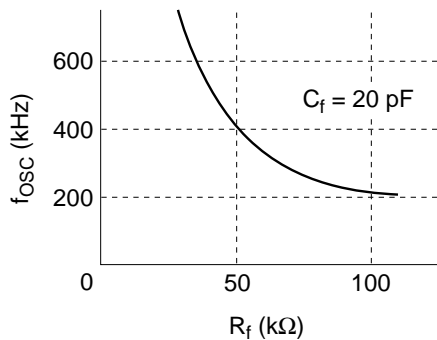

13. Resistance between terminal X and terminal V (one of V1L, V1R, V2L, V2R, V5L, V5R, V6L, and V6R) when load current flows through one of the terminals X1 to X64. This value is specified under the following conditions:

$$V_{CC} - V_{EE} = 10V$$

$$V1L = V1R, V6L = V6R = V_{CC} - 1/7 (V_{CC} - V_{EE})$$

$$V2L = V2R, V5L = V5R = V_{EE} + 1/7 (V_{CC} - V_{EE})$$

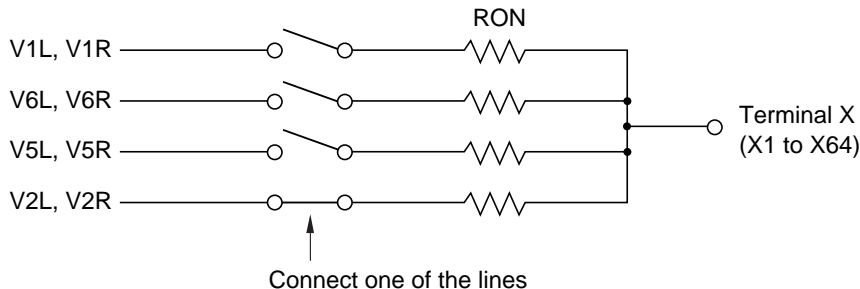

The following is a description of the range of power supply voltage for liquid crystal display drive. Apply positive voltage to V1L = V1R and V6L = V6R and negative voltage to V2L = V2R and V5L = V5R within the ΔV range. This range allows stable impedance on driver output (RON). Notice that ΔV depends on power supply voltage $V_{CC} - V_{EE}$.

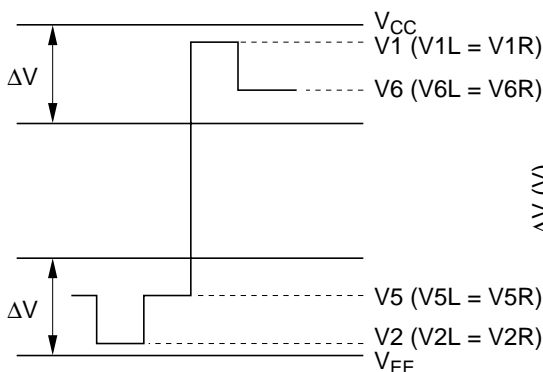

Correlation between driver output waveform and power supply voltage for liquid crystal display drive

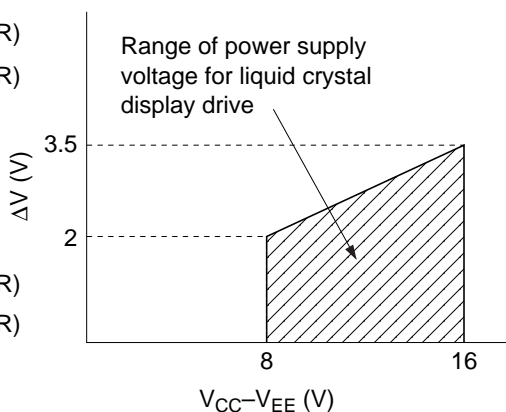

Correlation between power supply voltage $V_{CC} - V_{EE}$ and ΔV

14. Specified at +75°C for die products.

Terminal Configuration

Input Terminal

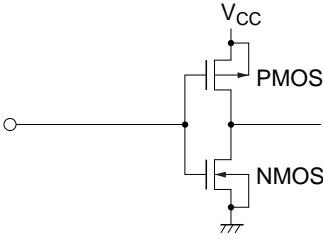

Applicable terminals:
CR, M/S, SHL, FCS, DS1, DS2, FS

I/O Terminal

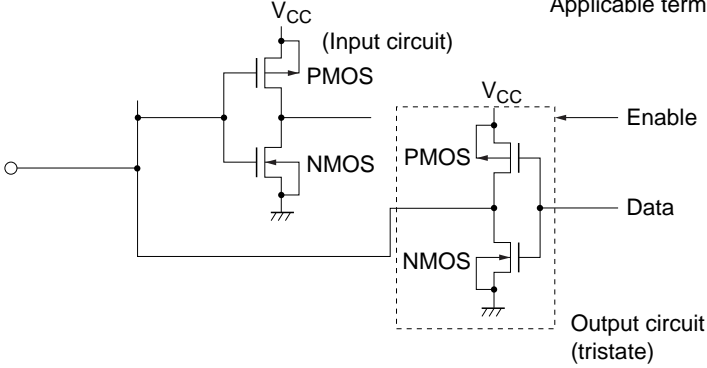

Applicable terminals: DL, DR, CL2, M

Output Terminal

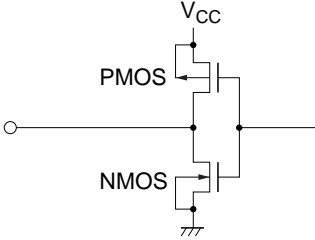

Applicable terminals: ø1, ø2, FRM

Output Terminal

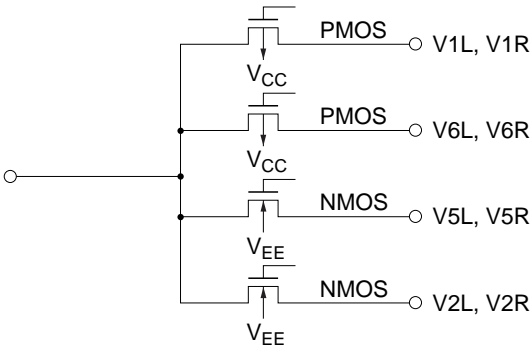

Applicable terminals:
X1 to X64

AC Characteristics ($V_{CC} = 2.7V$ to $5.5V$, $GND = 0V$, $T_a = -30$ to $+75^\circ C$)*2

In the Slave Mode (M/S = GND)

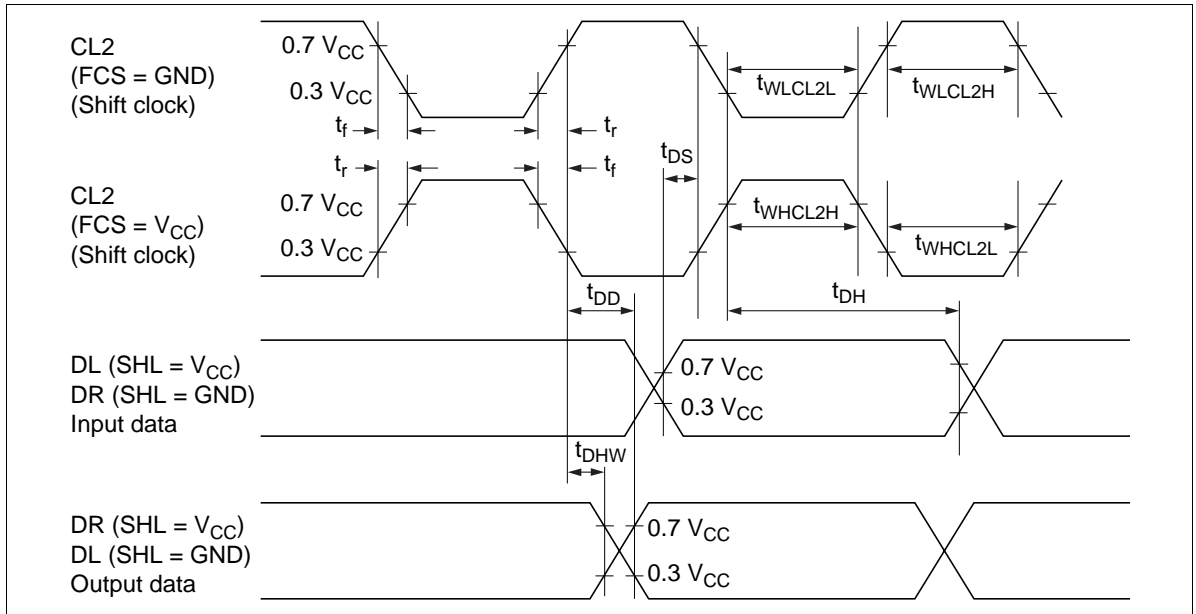

Item	Symbol	Min	Typ	Max	Unit	Note
CL2 low level width (FCS = GND)	t_{WLCL2L}	450	—	—	ns	
CL2 high level width (FCS = GND)	t_{WLCL2H}	150	—	—	ns	
CL2 low level width (FCS = V_{CC})	t_{WHCL2L}	150	—	—	ns	
CL2 high level width (FCS = V_{CC})	t_{WHCL2H}	450	—	—	ns	
Data setup time	t_{DS}	100	—	—	ns	
Data hold time	t_{DH}	100	—	—	ns	
Data delay time	t_{DD}	—	—	200	ns	1
Data hold time	t_{DHW}	10	—	—	ns	
CL2 rise time	t_r	—	—	30	ns	
CL2 fall time	t_f	—	—	30	ns	

Notes: 1. The following load circuit is connected for specification.

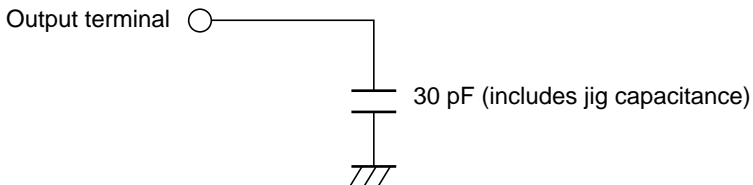

2. Specified at $+75^\circ C$ for die products.

3. In the master mode ($M/S = V_{CC}$, $FCS = V_{CC}$, $C_f = 20 \text{ pF}$, $R_f = 39 \text{ k}\Omega$)

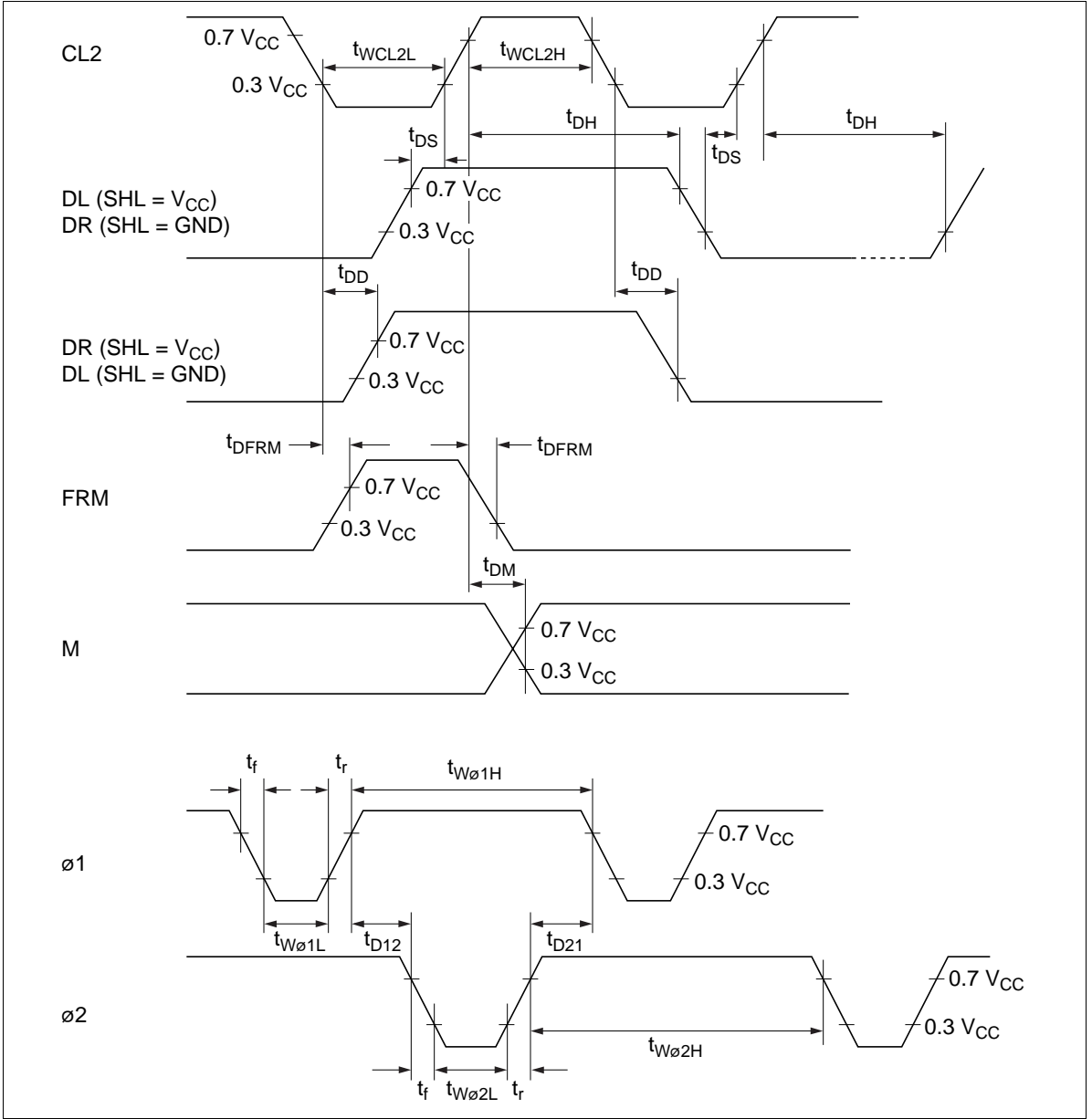

Item	Symbol	Min	Typ	Max	Unit
Data setup time	t_{DS}	20	—	—	μs
Data hold time	t_{DH}	40	—	—	μs
Data delay time	t_{DD}	5	—	—	μs
FRM delay time	t_{DFRM}	-2	—	+2	μs
M delay time	t_{DM}	-2	—	+2	μs
CL2 low level width	t_{WCL2L}	35	—	—	μs
CL2 high level width	t_{WCL2H}	35	—	—	μs
$\phi 1$ low level width	$t_{W\phi 1L}$	700	—	—	ns
$\phi 2$ low level width	$t_{W\phi 2L}$	700	—	—	ns
$\phi 1$ high level width	$t_{W\phi 1H}$	2100	—	—	ns
$\phi 2$ high level width	$t_{W\phi 2H}$	2100	—	—	ns
$\phi 1$ – $\phi 2$ phase difference	t_{D12}	700	—	—	ns
$\phi 2$ – $\phi 1$ phase difference	t_{D21}	700	—	—	ns
$\phi 1$, $\phi 2$ rise time	t_r	—	—	150	ns
$\phi 1$, $\phi 2$ fall time	t_f	—	—	150	ns

Cautions

1. Hitachi neither warrants nor grants licenses of any rights of Hitachi's or any third party's patent, copyright, trademark, or other intellectual property rights for information contained in this document. Hitachi bears no responsibility for problems that may arise with third party's rights, including intellectual property rights, in connection with use of the information contained in this document.
2. Products and product specifications may be subject to change without notice. Confirm that you have received the latest product standards or specifications before final design, purchase or use.
3. Hitachi makes every attempt to ensure that its products are of high quality and reliability. However, contact Hitachi's sales office before using the product in an application that demands especially high quality and reliability or where its failure or malfunction may directly threaten human life or cause risk of bodily injury, such as aerospace, aeronautics, nuclear power, combustion control, transportation, traffic, safety equipment or medical equipment for life support.
4. Design your application so that the product is used within the ranges guaranteed by Hitachi particularly for maximum rating, operating supply voltage range, heat radiation characteristics, installation conditions and other characteristics. Hitachi bears no responsibility for failure or damage when used beyond the guaranteed ranges. Even within the guaranteed ranges, consider normally foreseeable failure rates or failure modes in semiconductor devices and employ systemic measures such as fail-safes, so that the equipment incorporating Hitachi product does not cause bodily injury, fire or other consequential damage due to operation of the Hitachi product.
5. This product is not designed to be radiation resistant.
6. No one is permitted to reproduce or duplicate, in any form, the whole or part of this document without written approval from Hitachi.
7. Contact Hitachi's sales office for any questions regarding this document or Hitachi semiconductor products.

HITACHI**Hitachi, Ltd.**

Semiconductor & Integrated Circuits.
Nippon Bldg., 2-6-2, Ohte-machi, Chiyoda-ku, Tokyo 100-0004, Japan
Tel: Tokyo (03) 3270-2111 Fax: (03) 3270-5109

URL North America : <http://semiconductor.hitachi.com/>
 Europe : <http://www.hitachi-eu.com/hel/ecg>
 Asia (Singapore) : <http://www.has.hitachi.com.sg/grp3/sicd/index.htm>
 Asia (Taiwan) : http://www.hitachi.com.tw/E/Product/SICD_Frame.htm
 Asia (HongKong) : <http://www.hitachi.com.hk/eng/bo/grp3/index.htm>
 Japan : <http://www.hitachi.co.jp/Sicd/indx.htm>

For further information write to:

Hitachi Semiconductor
(America) Inc.
179 East Tasman Drive,
San Jose, CA 95134
Tel: <1> (408) 433-1990
Fax: <1> (408) 433-0223

Hitachi Europe GmbH
Electronic components Group
Dornacher Straße 3
D-85622 Feldkirchen, Munich
Germany
Tel: <49> (89) 9 9180-0
Fax: <49> (89) 9 29 30 00

Hitachi Europe Ltd.
Electronic Components Group.
Whitebrook Park
Lower Cookham Road
Maidenhead
Berkshire SL6 8YA, United Kingdom
Tel: <44> (1628) 585000
Fax: <44> (1628) 778322

Hitachi Asia Pte. Ltd.
16 Collyer Quay #20-00
Hitachi Tower
Singapore 049318
Tel: 535-2100
Fax: 535-1533

Hitachi Asia Ltd.
Taipei Branch Office
3F, Hung Kuo Building, No.167,
Tun-Hwa North Road, Taipei (105)
Tel: <886> (2) 2718-3666
Fax: <886> (2) 2718-8180

Hitachi Asia (Hong Kong) Ltd.
Group III (Electronic Components)
7/F., North Tower, World Finance Centre,
Harbour City, Canton Road, Tsim Sha Tsui,
Kowloon, Hong Kong
Tel: <852> (2) 735 9218
Fax: <852> (2) 730 0281
Telex: 40815 HITEC HX

Copyright © Hitachi, Ltd., 1998. All rights reserved. Printed in Japan.

This datasheet has been downloaded from:

www.DatasheetCatalog.com

Datasheets for electronic components.



LittleDiode supplies new, hard to find or obsolete electronic components and semiconductors all over the world.

With over two million different components listed you are sure to find the part you need.

Feel free to visit us today at our online store:

LittleDiode.com

Looking forward to providing you with the best possible service.