

FSA1256 • FSA1257 • FSA1258

Low R_{ON} Low Voltage Dual SPST Analog Switch

General Description

The FSA1256, FSA1257, and FSA1258 are high performance dual Single Pole/Single Throw (SPST) analog switches. These devices feature ultra low R_{ON} of 1.1 Ω maximum at 4.5V V_{CC} and will operate over the wide V_{CC} range of 1.65V to 5.5V. These devices are fabricated with sub-micron CMOS technology to achieve fast switching speeds and are designed for break-before-make operation. The select input is TTL level compatible. The FSA1256 features two Normally Open (NO) switches. The FSA1257 features two Normally Closed (NC) switches. The FSA1258 has one NO switch and one NC switch.

Features

- Maximum 1.1 Ω On Resistance (R_{ON}) for 4.5V supply
- 0.4 Ω max R_{ON} flatness for 4.5V supply
- Space saving Pb-Free MicroPak™ packaging
- Broad V_{CC} operating range: 1.65V to 5.5V
- Fast turn-on and turn-off time
- FSA1258 features break-before-make enable circuitry
- Over-voltage tolerant TTL compatible control input

Ordering Code:

Order Number	Package Number	Product Code Top Mark	Package Description	Supplied As
FSA1256L8X	MAC08A	EB	Pb-Free 8-Lead MicroPak, 1.6 mm Wide	5K Units on Tape and Reel
FSA1257L8X	MAC08A	EC	Pb-Free 8-Lead MicroPak, 1.6 mm Wide	5K Units on Tape and Reel
FSA1258L8X	MAC08A	ED	Pb-Free 8-Lead MicroPak, 1.6 mm Wide	5K Units on Tape and Reel

Pb-Free package per JEDEC J-STD-020B.

Analog Symbols

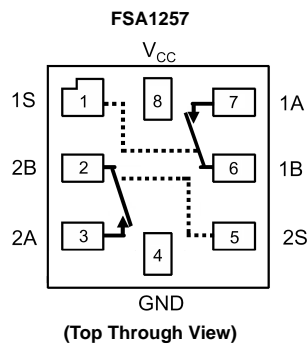
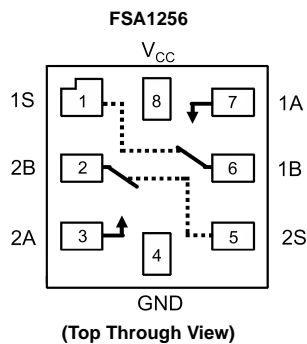

Truth Tables

FSA1256	
Control Input(s)	Function
L	Disconnect
H	A Connected to B

H = HIGH Logic Level L = LOW Logic Level

FSA1257	
Control Input(s)	Function
L	A Connected to B
H	Disconnect

MicroPak™ is a trademark of Fairchild Semiconductor Corporation.

Analog Symbol

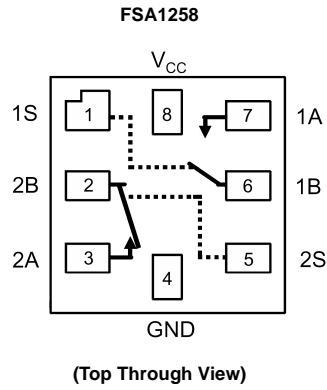

Truth Table

FSA1258			
Control Input 1S	Function	Control Input 2S	Function
L	1A Connected to 1B	L	Disconnect
H	Disconnect	H	2A Connected to 2B

H = HIGH Logic Level
L = LOW Logic Level

Pin Descriptions

Pin Names	Function
A, B	Data Ports
S	Control Input

Absolute Maximum Ratings ^(Note 1)		Recommended Operating Conditions	
Supply Voltage (V_{CC})	-0.5V to +6.0V	Supply Voltage (V_{CC})	1.65V to 5.5V
Switch Voltage (V_S) (Note 2)	-0.5V to $V_{CC} + 0.5V$	Control Input Voltage (V_{IN}) (Note 3)	0V to V_{CC}
Input Voltage (V_{IN}) (Note 2)	-0.5V to +6.0V	Switch Input Voltage (V_{IN})	0V to V_{CC}
Input Diode Current	-50 mA	Operating Temperature (T_A)	-40°C to +85°C
Switch Current	200 mA	Thermal Resistance (θ_{JA}) in still air	
Peak Switch Current (Pulsed at 1 ms duration, <10% Duty Cycle)	400 mA	MicroPak 8L package	224°C/W (modeled)
Power Dissipation @ 85°C			
MicroPak 8L package	180 mW		
Storage Temperature Range (T_{STG})	-65°C to +150°C	Note 1: The "Absolute Maximum Ratings" are those values beyond which the safety of the device cannot be guaranteed. The device should not be operated at these limits. The parametric values defined in the Electrical Characteristics tables are not guaranteed at the absolute maximum ratings. The "Recommended Operating Conditions" table will define the conditions for actual device operation.	
Maximum Junction Temperature (T_J)	+150°C	Note 2: The input and output negative voltage ratings may be exceeded if the input and output diode current ratings are observed.	
Lead Temperature (T_L)		Note 3: Unused inputs must be held HIGH or LOW. They may not float.	
Soldering, 10 seconds	+260°C		
ESD			
Human Body Model	5.5kV		

DC Electrical Characteristics (All typical values are @ 25°C unless otherwise specified)

Symbol	Parameter	V_{CC} (V)	$T_A = +25^\circ\text{C}$		$T_A = -40^\circ\text{C to } +85^\circ\text{C}$		Units	Conditions
			Min	Typ	Max	Min		
V_{IH}	Input Voltage High	2.7 to 3.6			2.0		V	
		4.5 to 5.5			2.4			
V_{IL}	Input Voltage Low	2.7 to 3.6			0.6		V	
		4.5 to 5.5			0.8			
I_{IN}	Control Input Leakage	2.7 to 3.6			-1.0	1.0	μA	$V_{IN} = 0V \text{ to } V_{CC}$
		4.5 to 5.5			-1.0	1.0		
$I_{NO(OFF)}, I_{NC(OFF)}$	OFF-Leakage Current	5.5	-2.0	2.0	-20.0	20.0	nA	A = 1V, 4.5V 1B or 2B = 1V, 4.5V
R_{ON}	Switch On Resistance (Note 4)	2.7	2.6	4.0	4.3		Ω	$I_{OUT} = 100 \text{ mA}, 1B \text{ or } 2B = 1.5V$
		4.5	0.95	1.18	1.3			$I_{OUT} = 100 \text{ mA}, 1B \text{ or } 2B = 3.5V$
ΔR_{ON}	On Resistance Matching Between Channels (Note 5)	4.5	0.06	0.12	0.15		Ω	$I_{OUT} = 100 \text{ mA}, 1B \text{ or } 2B = 3.5V$
$R_{FLAT(ON)}$	On Resistance Flatness (Note 6)	2.7	1.4				Ω	$I_{OUT} = 100 \text{ mA}, 1B \text{ or } 2B = 0V, 0.75V, 1.5V$
		4.5	0.2	0.3	0.4			$I_{OUT} = 100 \text{ mA}, 1B \text{ or } 2B = 0V, 1V, 2V$
I_{CC}	Quiescent Supply Current	3.6	0.1	0.5	1.0		μA	$V_{IN} = 0V \text{ or } V_{CC}, I_{OUT} = 0V$
		5.5	0.1	0.5	1.0			

Note 4: On Resistance is determined by the voltage drop between A and B pins at the indicated current through the switch.

Note 5: $\Delta R_{ON} = R_{ONmax} - R_{ONmin}$ measured at identical V_{CC} , temperature, and voltage.

Note 6: Flatness is defined as the difference between the maximum and minimum value of On Resistance over the specified range of conditions.

AC Electrical Characteristics (All typical value are @ 25°C unless otherwise specified)

Symbol	Parameter	V _{CC} (V)	T _A = +25°C			T _A = -40°C to +85°C		Units	Conditions	Figure Number
			Min	Typ	Max	Min	Max			
t _{ON}	Turn ON Time	2.7 to 3.6	15.0	50.0		60.0	ns	1B or 2B = 1.5V, R _L = 50Ω, C _L = 35 pF	Figure 1	
		4.5 to 5.5	10.0	35.0		40.0		1B or 2B = 3.0V, R _L = 50Ω, C _L = 35 pF		
t _{OFF}	Turn OFF Time	2.7 to 3.6	4.0	20.0		30.0	ns	1B or 2B = 1.5V, R _L = 50Ω, C _L = 35 pF	Figure 1	
		4.5 to 5.5	8.0	15.0		20.0		1B or 2B = 3.0V, R _L = 50Ω, C _L = 35 pF		
t _{B-M}	Break-Before-Make Time	2.7 to 3.6	12.0				ns	1B or 2B = 1.5V, R _L = 50Ω, C _L = 35 pF	Figure 2	
		4.5 to 5.5	7.0					1B or 2B = 3.0V, R _L = 50Ω, C _L = 35 pF		
Q	Charge Injection	2.7 to 3.6	10.0				pC	C _L = 1.0 nF, V _{GEN} = 0V, R _{GEN} = 0Ω	Figure 4	
		4.5 to 5.5	20.0							
OIRR	OFF-Isolation	2.7 to 3.6	-70.0				dB	f = 1MHz, R _L = 50Ω	Figure 3	
		4.5 to 5.5	-70.0							
Xtalk	Crosstalk	2.7 to 3.6	-100				dB	f = 1MHz, R _L = 50Ω	Figure 6	
		4.5 to 5.5	-100							
BW	-3db Bandwidth	2.7 to 3.6	300				MHz	R _L = 50Ω	Figure 7	
		4.5 to 5.5	300							
THD	Total Harmonic Distortion	2.7 to 3.6	0.002				%	R _L = 600Ω, V _{IN} = 0.5V P.P, f = 20Hz to 20kHz	Figure 8	
		4.5 to 5.5	0.002							

Capacitance

Symbol	Parameter	V _{CC} (V)	T _A = +25°C			T _A = 40°C to +85°C		Units	Conditions
			Min	Typ	Max	Min	Max		
C _{IN}	Control Pin Input Capacitance	0.0		3.0			pF	f = 1MHz (see Figure 6)	
C _{OFF}	B Port OFF Capacitance	4.5		11.5			pF	f = 1MHz (see Figure 6)	
C _{ON}	A Port ON Capacitance	4.5		27.0			pF	f = 1MHz (see Figure 6)	

AC Loading and Waveforms

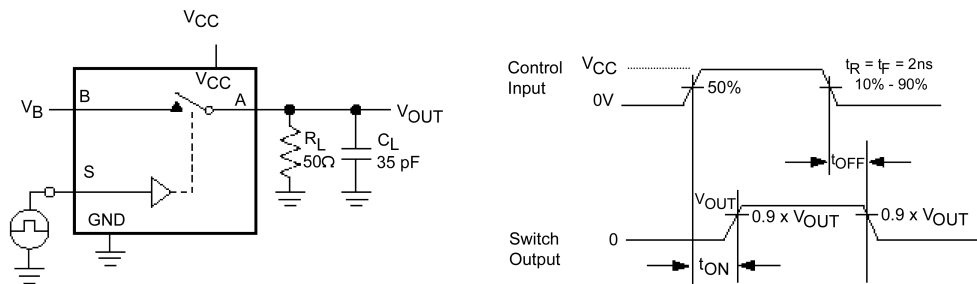

C_L includes Fixture and Stray Capacitance

Logic Input Waveforms Inverted for Switches that have the Opposite Logic Sense

FIGURE 1. Turn-On/Turn-Off Timing

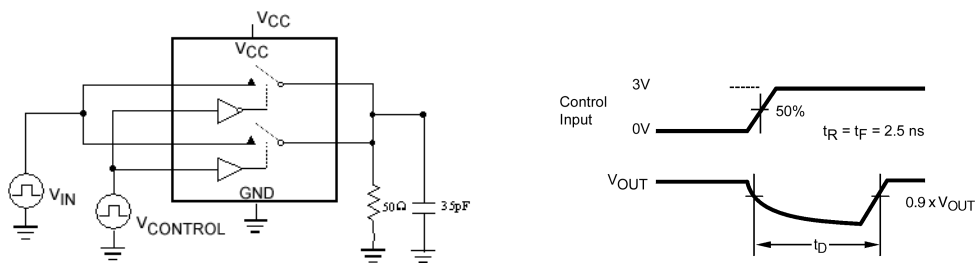

FIGURE 2. Break-Before-Make Timing

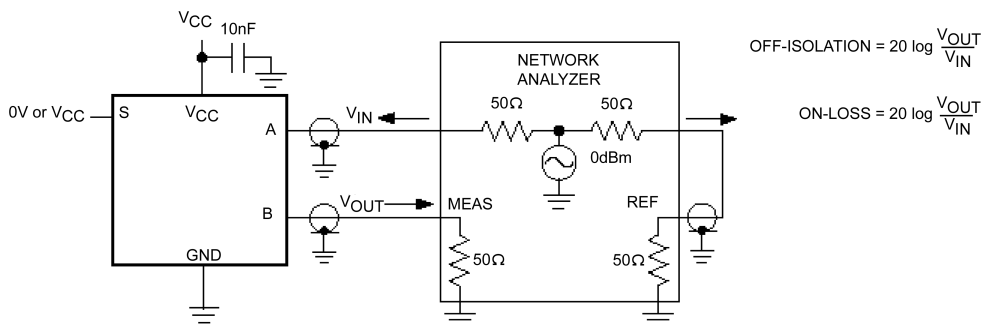

FIGURE 3. OFF Isolation

AC Loading and Waveforms (Continued)

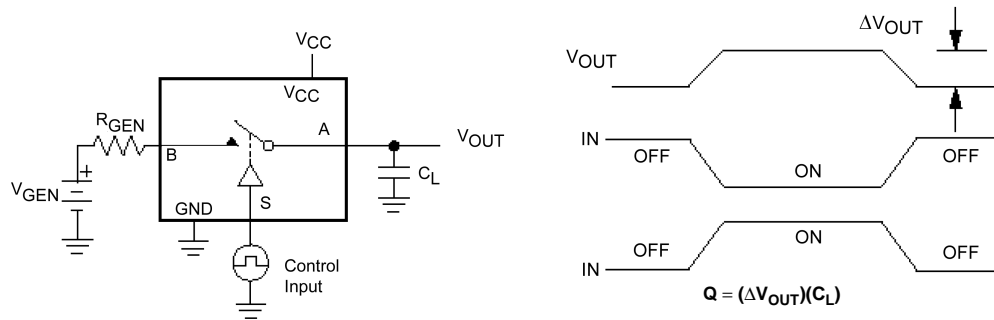

FIGURE 4. Charge Injection

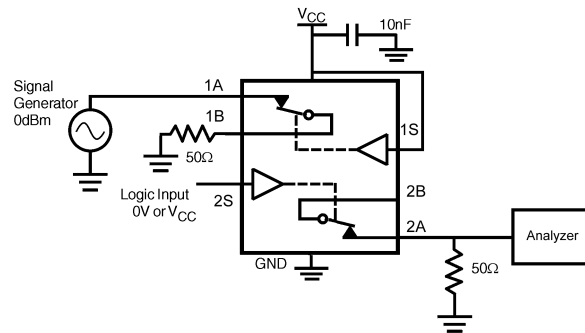

FIGURE 5. Crosstalk

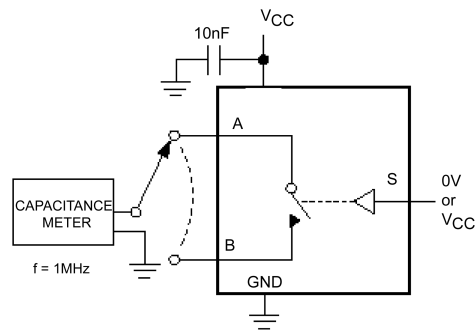

FIGURE 6. ON/OFF Capacitance Measurement Setup

AC Loading and Waveforms (Continued)

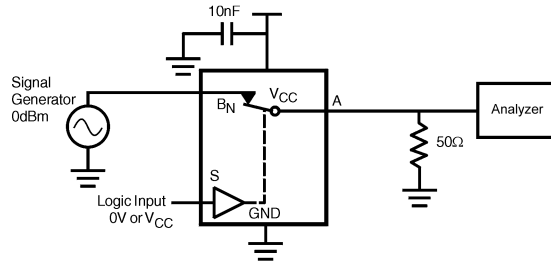

FIGURE 7. Bandwidth

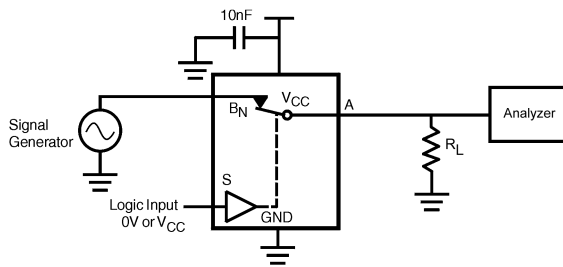
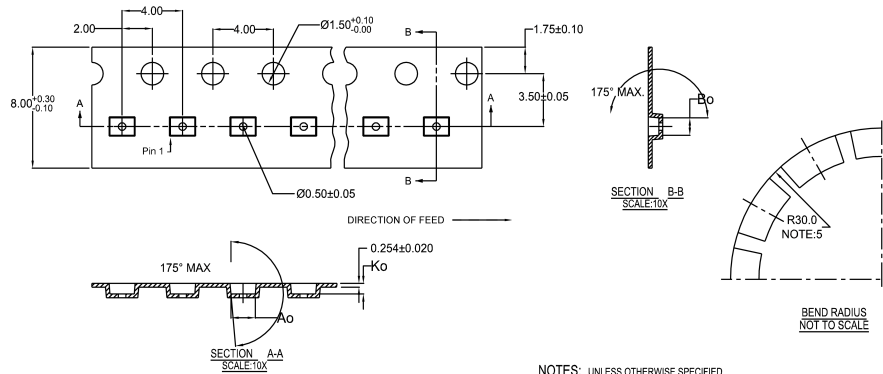

FIGURE 8. Harmonic Distortion

Tape and Reel Specification

Tape Format For Micropak

Package Designator	Tape Section	Number Cavities	Cavity Status	Cover Tape Status
L8X	Leader (Start End)	125 (typ)	Empty	Sealed
	Carrier	5000	Filled	Sealed
	Trailer (Hub End)	75 (typ)	Empty	Sealed



10	300056	2.30±0.05	1.78±0.05	0.68±0.05
8	300038	1.78±0.05	1.78±0.05	0.68±0.05
6	300033	1.60±0.05	1.15±0.05	0.70±0.05

NOTES: UNLESS OTHERWISE SPECIFIED

1. ACCUMULATED 50 SPROCKETS, SPROCKET HOLE PITCH IS 200.00 ±0.30MM
2. NO INDICATED CORNER RADIUS IS 0.127MM
3. CAMBER NOT TO EXCEED 1MM IN 100MM
4. SMALLEST ALLOWABLE BENDING RADIUS
5. POCKET POSITION RELATIVE TO SPROCKET HOLE MEASURED AS TRUE POSITION OF POCKET, NOT POCKET HOLE



SCALE: 6X

REEL DIMENSIONS inches (millimeters)

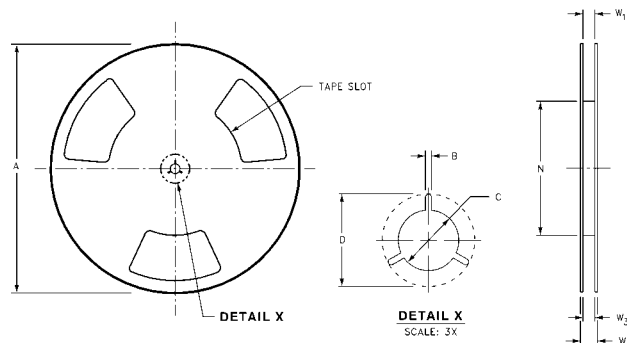

Tape Size	A	B	C	D	N	W1	W2	W3
8 mm	7.0 (177.8)	0.059 (1.50)	0.512 (13.00)	0.795 (20.20)	2.165 (55.00)	0.331 + 0.059/-0.000 (8.40 + 1.50/-0.00)	0.567 (14.40)	W1 + 0.078/-0.039 (W1 + 2.00/-1.00)

Physical Dimensions inches (millimeters) unless otherwise noted

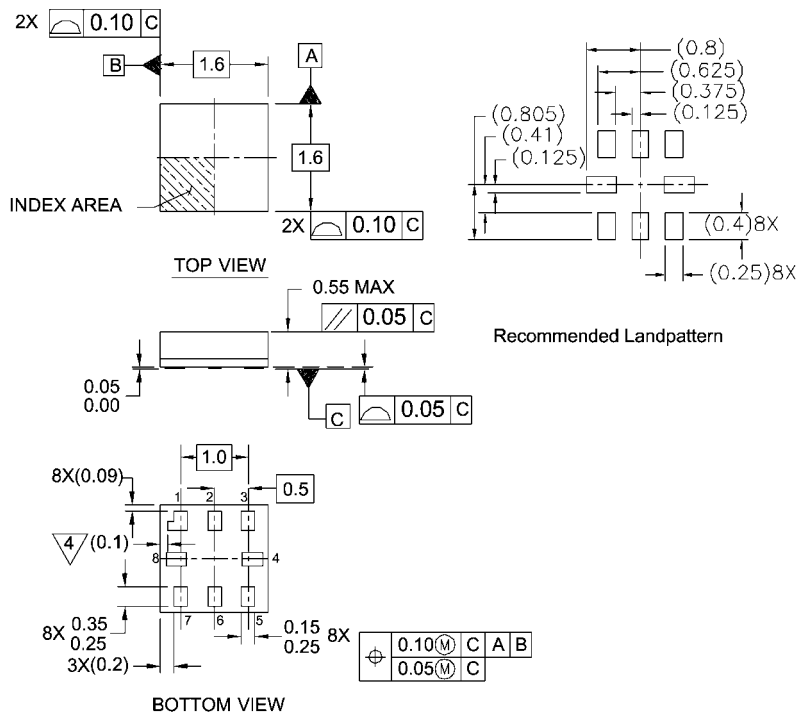

Notes:

1. PACKAGE CONFORMS TO JEDEC MO-255 VARIATION UAAD
2. DIMENSIONS ARE IN MILLIMETERS
3. DRAWING CONFORMS TO ASME Y.14M-1994

4/PIN 1 FLAG, END OF PACKAGE OFFSET.

MAC08AREVC

**Pb-Free 8-Lead MicroPak, 1.6 mm Wide
Package Number MAC08A**

Fairchild does not assume any responsibility for use of any circuitry described, no circuit patent licenses are implied and Fairchild reserves the right at any time without notice to change said circuitry and specifications.

LIFE SUPPORT POLICY

FAIRCHILD'S PRODUCTS ARE NOT AUTHORIZED FOR USE AS CRITICAL COMPONENTS IN LIFE SUPPORT DEVICES OR SYSTEMS WITHOUT THE EXPRESS WRITTEN APPROVAL OF THE PRESIDENT OF FAIRCHILD SEMICONDUCTOR CORPORATION. As used herein:

1. Life support devices or systems are devices or systems which, (a) are intended for surgical implant into the body, or (b) support or sustain life, and (c) whose failure to perform when properly used in accordance with instructions for use provided in the labeling, can be reasonably expected to result in a significant injury to the user.
2. A critical component in any component of a life support device or system whose failure to perform can be reasonably expected to cause the failure of the life support device or system, or to affect its safety or effectiveness.

www.fairchildsemi.com



LittleDiode supplies new, hard to find or obsolete electronic components and semiconductors all over the world.

With over two million different components listed you are sure to find the part you need.

Feel free to visit us today at our online store:

LittleDiode.com

Looking forward to providing you with the best possible service.