



ADG918/ADG919

FEATURES

- Wideband switch: $-3\text{ dB @ }4\text{ GHz}$
- Absorptive/reflective switches
- High off isolation ($43\text{ dB @ }1\text{ GHz}$)
- Low insertion loss ($0.8\text{ dB @ }1\text{ GHz}$)
- Single 1.65 V to 2.75 V power supply
- CMOS/LVTTL control logic
- 8-lead MSOP and tiny $3\text{ mm} \times 3\text{ mm}$ LFCSP packages
- Low power consumption ($<1\text{ }\mu\text{A}$)

APPLICATIONS

- Wireless communications
- General-purpose RF switching
- Dual-band applications
- High speed filter selection
- Digital transceiver front end switch
- IF switching
- Tuner modules
- Antenna diversity switching

GENERAL DESCRIPTION

The ADG918/ADG919 are wideband switches using a CMOS process to provide high isolation and low insertion loss to 1 GHz. The ADG918 is an absorptive (matched) switch having $50\text{ }\Omega$ terminated shunt legs, while the ADG919 is a reflective switch. These devices are designed such that the isolation is high over the dc to 1 GHz frequency range. They have on-board CMOS control logic, thus eliminating the need for external controlling circuitry. The control inputs are both CMOS and

FUNCTIONAL BLOCK DIAGRAMS

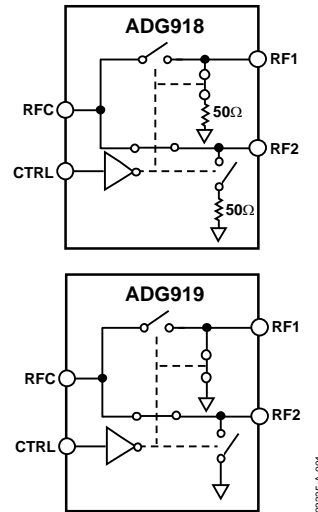

Figure 1.

LVTTL compatible. The low power consumption of these CMOS devices makes them ideally suited to wireless applications and general-purpose high frequency switching.

PRODUCT HIGHLIGHTS

- -43 dB Off Isolation @ 1 GHz.
- 0.8 dB Insertion Loss @ 1 GHz.
- Tiny 8-Lead MSOP/LFCSP Packages.

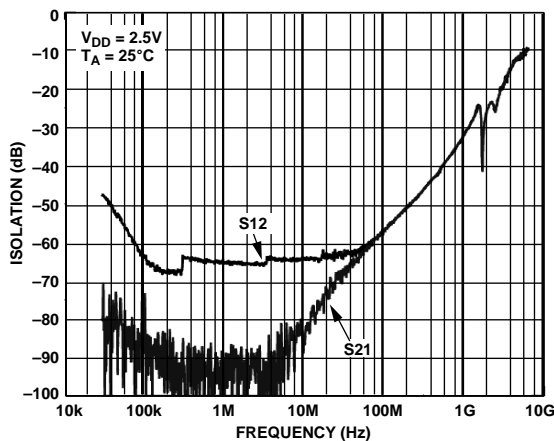

Figure 2. Off Isolation vs. Frequency

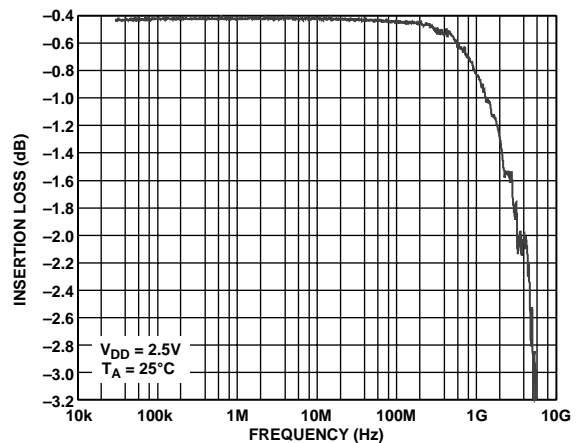

Figure 3. Insertion Loss vs. Frequency

Rev. A

Information furnished by Analog Devices is believed to be accurate and reliable. However, no responsibility is assumed by Analog Devices for its use, nor for any infringements of patents or other rights of third parties that may result from its use. Specifications subject to change without notice. No license is granted by implication or otherwise under any patent or patent rights of Analog Devices. Trademarks and registered trademarks are the property of their respective owners.

TABLE OF CONTENTS

ADG918/ADG919–Specifications	3	Absorptive vs. Reflective	12
Absolute Maximum Ratings.....	4	Wireless Metering.....	12
ESD Caution.....	4	Tuner Modules.....	12
Pin Configuration and Function Descriptions.....	5	Filter Selection	12
Terminology	6	ADG9xx Evaluation Board	13
Typical Performance Characteristics	7	Outline Dimensions	14
Test Circuits.....	10	Ordering Guide	14
Applications.....	12		

REVISION HISTORY

9/04—Changed from Rev. 0 to Rev. A

Updated Format.....	Universal
Change to Data Sheet Title	1
Change to Features.....	1
Change to Product Highlights.....	1
Changes to Specifications.....	3
Change to ADG9xx Evaluation Board section.....	13
Changes to Ordering Guide.....	14

8/03 Revision 0: Initial Version

SPECIFICATIONS

Table 1. $V_{DD} = 1.65\text{ V to }2.75\text{ V}$, $GND = 0\text{ V}$, input power = 0 dBm, all specifications T_{MIN} to T_{MAX} , unless otherwise noted.¹

Parameter	Symbol	Conditions	B Version			Unit
			Min	Typ ²	Max	
AC ELECTRICAL CHARACTERISTICS						
Operating Frequency ³			DC		2	GHz
3 dB Frequency ⁴					4	GHz
Input Power ⁴		0 V dc Bias			7	dBm
		0.5 V dc Bias			16	dBm
Insertion Loss	S_{21}, S_{12}	DC to 100 MHz; $V_{DD} = 2.5\text{ V} \pm 10\%$		0.4	0.7	dB
		500 MHz; $V_{DD} = 2.5\text{ V} \pm 10\%$		0.5	0.8	dB
		1000 MHz; $V_{DD} = 2.5\text{ V} \pm 10\%$		0.8	1.25	dB
Isolation—RFC to RF1/RF2 (CP Package)	S_{21}, S_{12}	100 MHz	57	60		dB
		500 MHz	46	49		dB
		1000 MHz	36	43		dB
Isolation—RFC to RF1/RF2 (RM Package)	S_{21}, S_{12}	100 MHz	55	60		dB
		500 MHz	43	47		dB
		1000 MHz	34	37		dB
Isolation—RF1 to RF2 (Crosstalk) (CP Package)	S_{21}, S_{12}	100 MHz	55	58		
		500 MHz	41	44		
		1000 MHz	31	37		
Isolation—RF1 to RF2 (Crosstalk) (RM Package)	S_{21}, S_{12}	100 MHz	54	57		
		500 MHz	39	42		
		1000 MHz	31	33		
Return Loss (On Channel) ⁴	S_{11}, S_{22}	DC to 100 MHz	21	27		dB
		500 MHz	22	27		dB
		1000 MHz	22	26		dB
Return Loss (Off Channel) ⁴ ADG918	S_{11}, S_{22}	DC to 100 MHz	18	23		dB
		500 MHz	17	21		dB
		1000 MHz	16	20		dB
On Switching Time ⁴	t_{ON}	50% CTRL to 90% RF		6.6	10	ns
Off Switching Time ⁴	t_{OFF}	50% CTRL to 10% RF		6.5	9.5	ns
Rise Time ⁴	t_{RISE}	10% to 90% RF		6.1	9	ns
Fall Time ⁴	t_{FALL}	90% to 10% RF		6.1	9	ns
1 dB Compression ⁴	$P_{-1\text{ dB}}$	1000 MHz		17		dBm
Third Order Intermodulation Intercept	IP_3	900 MHz/901 MHz, 4 dBm	30	36		dBm
Video Feedthrough ⁵				2.5		mV p-p
DC ELECTRICAL CHARACTERISTICS						
Input High Voltage	V_{INH}	$V_{DD} = 2.25\text{ V to }2.75\text{ V}$	1.7			V
	V_{INH}	$V_{DD} = 1.65\text{ V to }1.95\text{ V}$	0.65 V_{CC}			V
Input Low Voltage	V_{INL}	$V_{DD} = 2.25\text{ V to }2.75\text{ V}$			0.7	V
	V_{INL}	$V_{DD} = 1.65\text{ V to }1.95\text{ V}$			0.35 V_{CC}	V
Input Leakage Current	I_I	$0 \leq V_{IN} \leq 2.75\text{ V}$		± 0.1	± 1	μA
CAPACITANCE ⁴						
RF1/RF2, RF Port On Capacitance	$C_{RF\text{ ON}}$	$f = 1\text{ MHz}$		1.6		pF
CTRL Input Capacitance	C_{CTRL}	$f = 1\text{ MHz}$		2		pF
POWER REQUIREMENTS						
V_{DD}			1.65		2.75	V
Quiescent Power Supply Current	I_{DD}	Digital inputs = 0 V or V_{DD}		0.1	1	μA

¹Temperature range B Version: $-40^\circ\text{C to }+85^\circ\text{C}$.

²Typical values are at $V_{DD} = 2.5\text{ V}$ and 25°C , unless otherwise stated.

³Point at which insertion loss degrades by 1 dB.

⁴Guaranteed by design, not subject to production test.

⁵The dc transience at the output of any port of the switch when the control voltage is switched from high to low or low to high in a $50\ \Omega$ test setup, measured with 1 ns rise time pulses and 500 MHz bandwidth.

ABSOLUTE MAXIMUM RATINGS¹

Table 2. (T_A = 25°C, unless otherwise noted.)

Parameter	Rating
V _{DD} to GND	-0.5 V to +4 V
Inputs to GND	-0.5 V to V _{DD} + 0.3 V ²
Continuous Current	30 mA
Input Power	18 dBm
Operating Temperature Range	
Industrial (B Version)	-40°C to +85°C
Storage Temperature Range	-65°C to +150°C
Junction Temperature	150°C
MSOP Package	
θ _{JA} Thermal Impedance	206°C/W
LFCSP Package	
θ _{JA} Thermal Impedance (2-layer board)	84°C/W
θ _{JA} Thermal Impedance (4-layer board)	48°C/W
Lead Temperature, Soldering (10 sec)	300°C
IR Reflow, Peak Temperature (<20 sec)	235°C
ESD	1 kV

NOTES

¹ Stresses above those listed under Absolute Maximum Ratings may cause permanent damage to the device. This is a stress rating only; functional operation of the device at these or any other conditions above those listed in the operational sections of this specification is not implied. Exposure to absolute maximum rating conditions for extended periods may affect device reliability. Only one absolute maximum rating may be applied at any one time.

² RF1/RF2 Off Port Inputs to Ground -0.5 V to V_{DD} - 0.5 V

ESD CAUTION

ESD (electrostatic discharge) sensitive device. Electrostatic charges as high as 4000 V readily accumulate on the human body and test equipment and can discharge without detection. Although this product features proprietary ESD protection circuitry, permanent damage may occur on devices subjected to high energy electrostatic discharges. Therefore, proper ESD precautions are recommended to avoid performance degradation or loss of functionality.



PIN CONFIGURATION AND FUNCTION DESCRIPTIONS

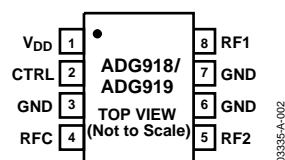

Figure 4. 8-Lead MSOP (RM-8)
8-Lead 3 mm x 3 mm LFCSP (CP-8)

Table 3. Truth Table

CTRL	Signal Path
0	RF2 to RFC
1	RF1 to RFC

Table 4. Pin Function Descriptions

Pin No.	Mnemonic	Function
1	V _{DD}	Power Supply Input. These parts can be operated from 1.65 V to 2.75 V, and V _{DD} should be decoupled to GND.
2	CTRL	CMOS or TTL Logic Level; 0->RF2 to RFC 1->RF1 to RFC
3, 6, 7	GND	Ground Reference Point for All Circuitry on the Part
4	RFC	COMMON RF Port for Switch
5	RF2	RF2 Port
8	RF1	RF1 Port

TERMINOLOGY

Table 5. Terminology

Parameter	Description
V_{DD}	Most positive power supply potential
I_{DD}	Positive supply current
GND	Ground (0 V) reference
CTRL	Logic control input
V_{INL}	Maximum input voltage for Logic 0
V_{INH}	Minimum input voltage for Logic 1
I_{INL} (I_{INH})	Input current of the digital input
C_{IN}	Digital input capacitance
t_{ON}	Delay between applying the digital control input and the output switching on.
t_{OFF}	Delay between applying the digital control input and the output switching off.
t_{RISE}	Rise time. Time for the RF signal to rise from 10% to 90% of the ON level.
t_{FALL}	Fall time. Time for the RF signal to fall from 90% to 10% of the ON level.
Off Isolation	The attenuation between input and output ports of the switch when the switch control voltage is in the OFF condition.
Insertion Loss	The attenuation between input and output ports of the switch when the switch control voltage is in the ON condition.
$P_{-1\text{ dB}}$	1 dB compression point. The RF input power level at which the switch insertion loss increases by 1 dB over its low level value. It is a measure of how much power the ON switch can handle before the insertion loss increases by 1 dB.
IP_3	Third order intermodulation intercept. This is a measure of the power in false tones that occur when closely spaced tones are passed through a switch, whereby the nonlinearity of the switch causes these false tones to be generated.
Return Loss	The amount of reflected power relative to the incident power at a port. Large return loss indicates good matching. By measuring return loss the VSWR can be calculated from conversion charts. VSWR (voltage standing wave ratio) indicates degree of matching present at a switch RF port.
Video Feedthrough	Spurious signals present at the RF ports of the switch when the control voltage is switched from high to low or low to high without an RF signal present.

TYPICAL PERFORMANCE CHARACTERISTICS

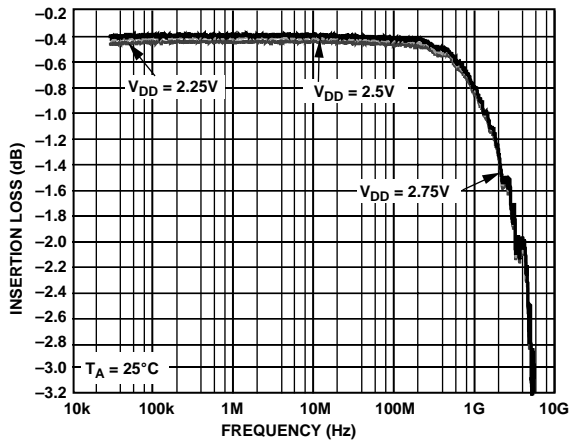

Figure 5. Insertion Loss vs. Frequency over Supplies (RF1/RF2, S12, and S21)

03335-A-017

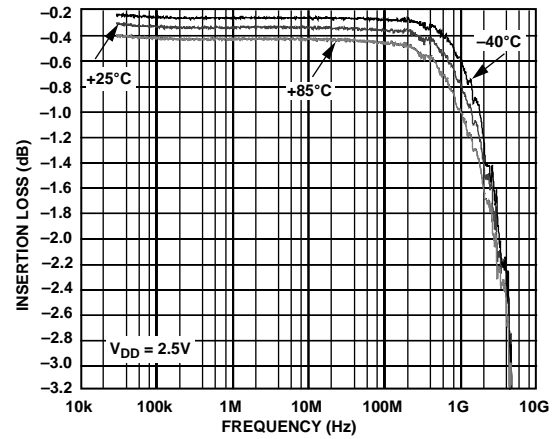

Figure 8. Insertion Loss vs. Frequency over Temperature (RF1/RF2, S12, and S21)

03335-A-018

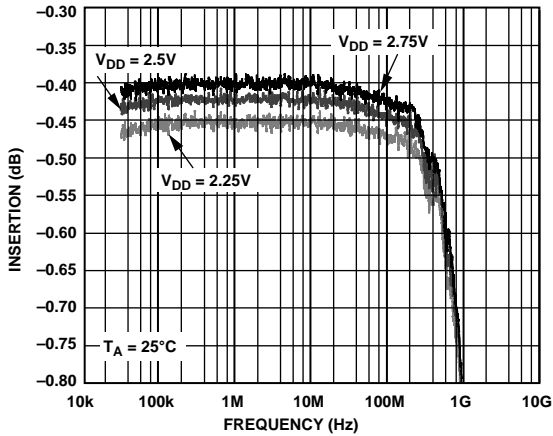

Figure 6. Insertion Loss vs. Frequency over Supplies (RF1/RF2, S12, and S21) (Zoomed Figure 5 Plot)

03335-A-019

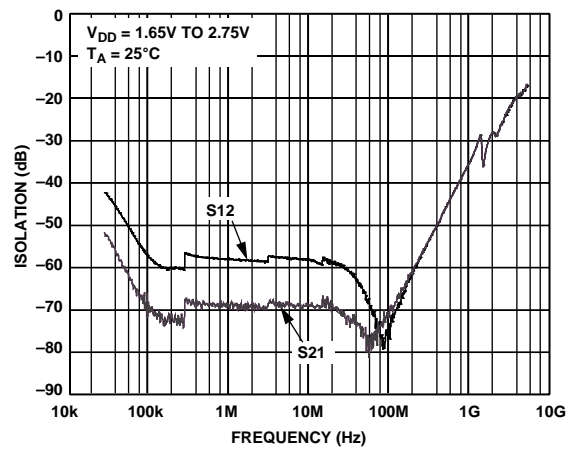

Figure 9. Isolation vs. Frequency over Supplies (RF1/RF2, ADG918)

03335-A-020

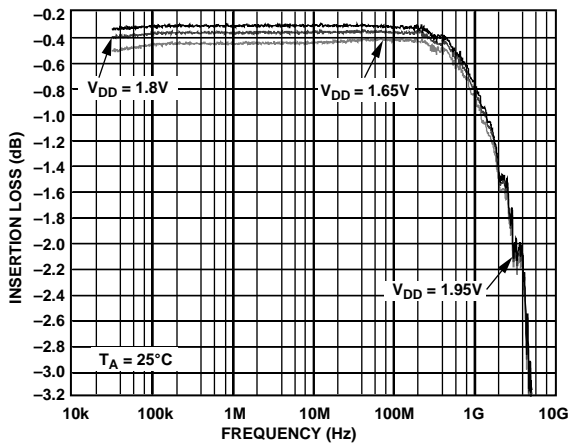

Figure 7. Insertion Loss vs. Frequency over Supplies (RF1/RF2, S12, and S21)

03335-A-021

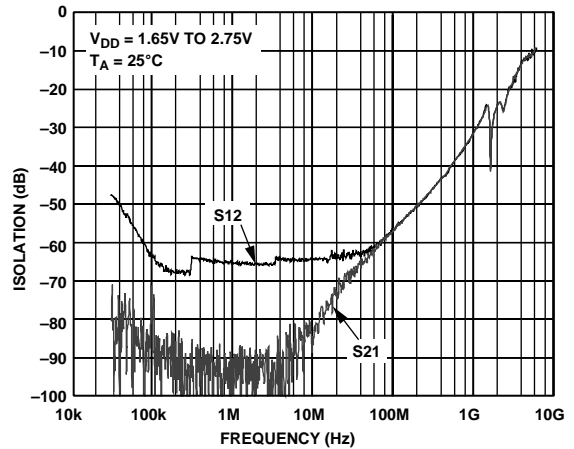

Figure 10. Isolation vs. Frequency over Supplies (RF1/RF2, ADG919)

03335-A-022

ADG918/ADG919

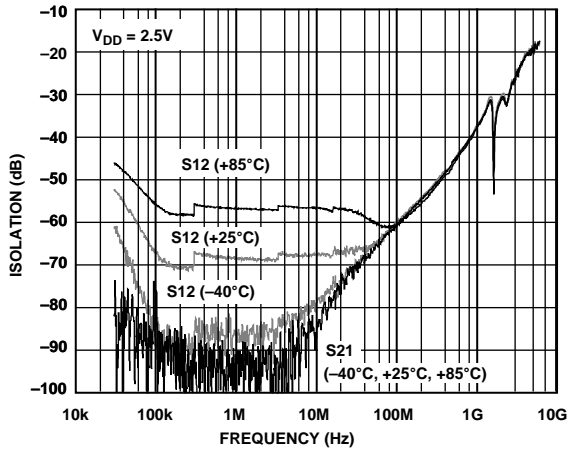

Figure 11. Isolation vs. Frequency over Temperature (RF1/RF2, ADG919)

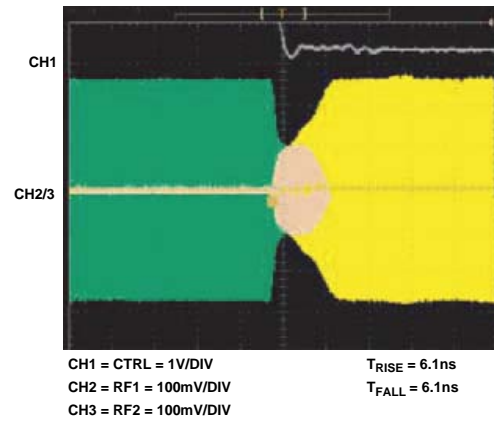

Figure 14. Switch Timing

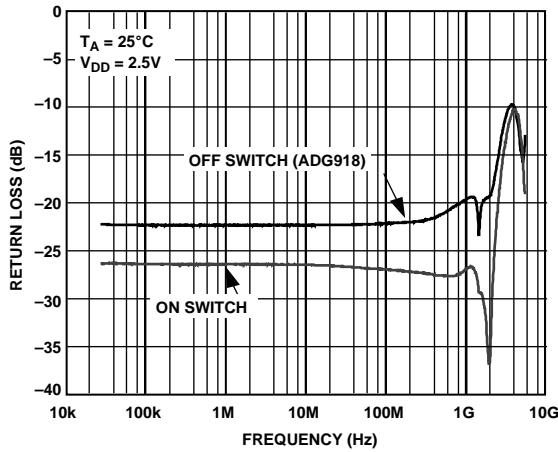

Figure 12. Return Loss vs. Frequency (RF1/RF2, S11)

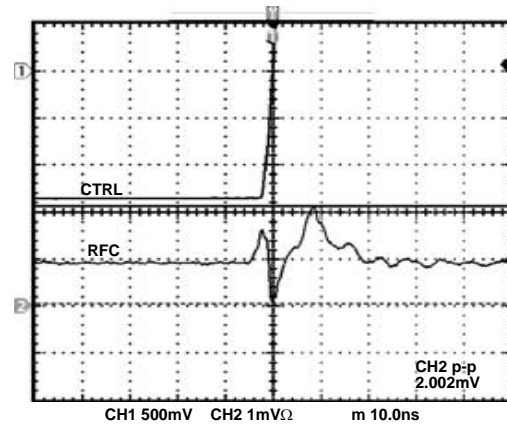

Figure 15. Video Feedthrough

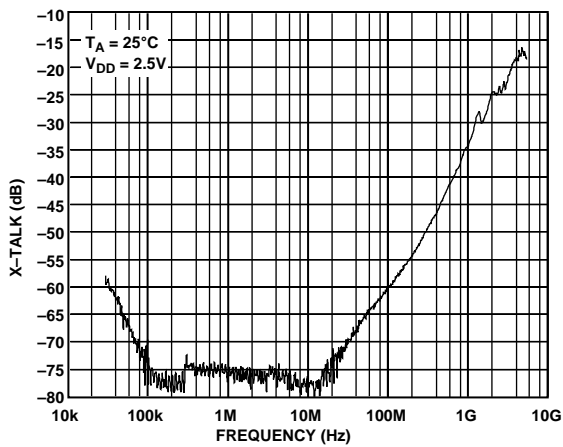

Figure 13. Crosstalk vs. Frequency (RF1/RF2, S12, S21)

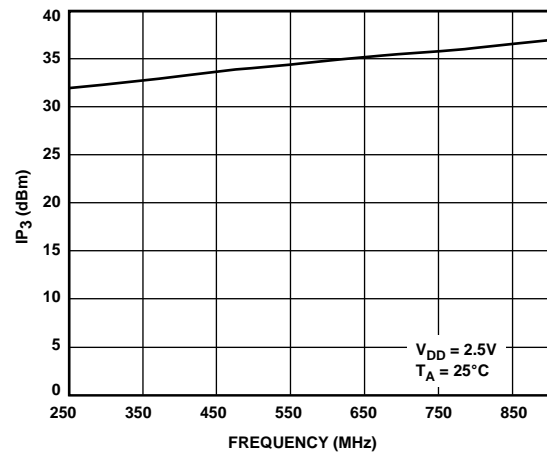

Figure 16. IP₃ vs. Frequency

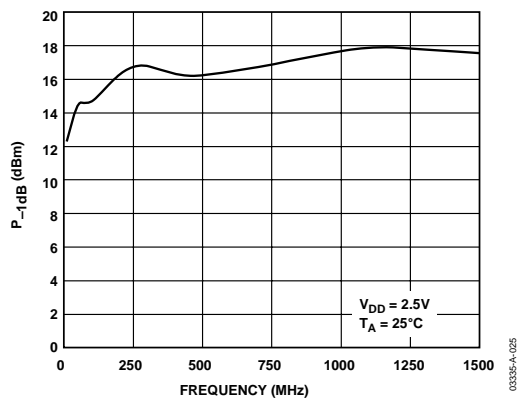

Figure 17. P_{-1dB} vs. Frequency

TEST CIRCUITS*

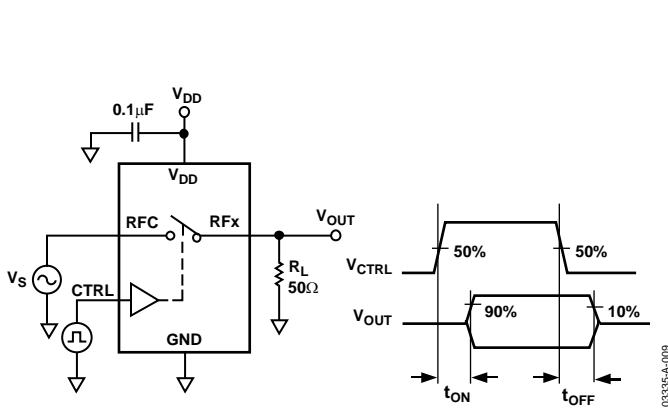

Figure 18. Switch Timing: t_{ON} t_{OFF}

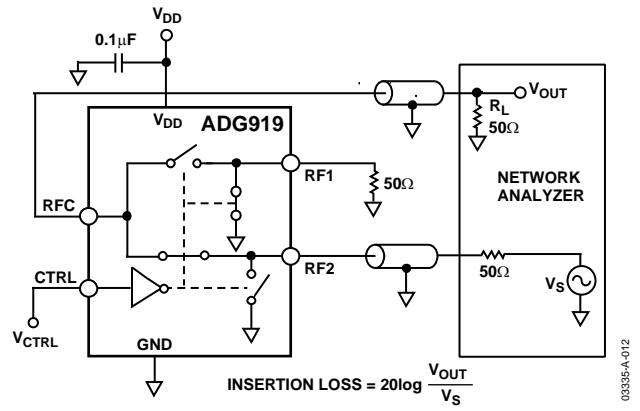

Figure 21. Insertion Loss

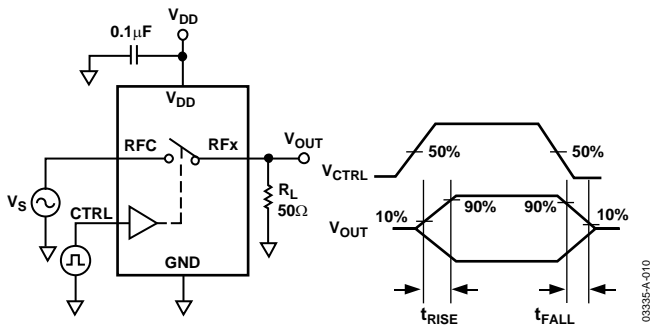

Figure 19. Switch Timing: t_{RISE} t_{FALL}

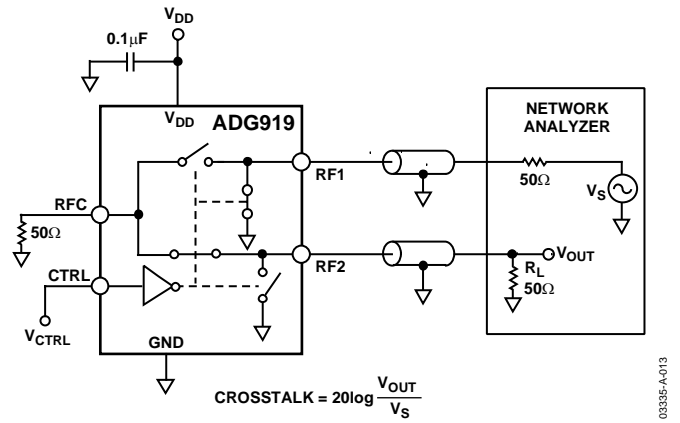

Figure 22. Crosstalk

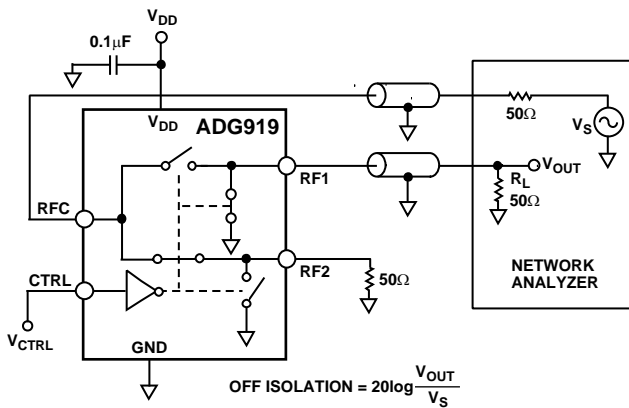

Figure 20. Off Isolation

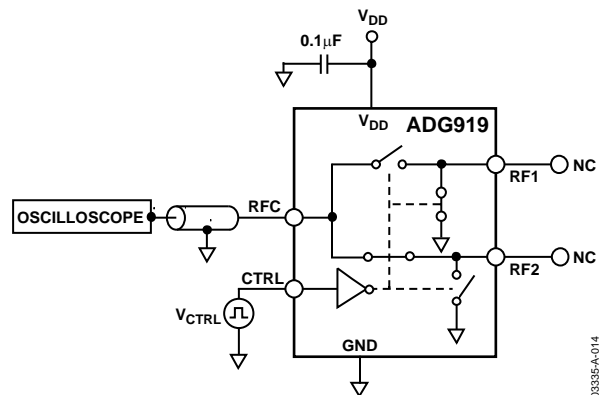

Figure 23. Video Feedthrough

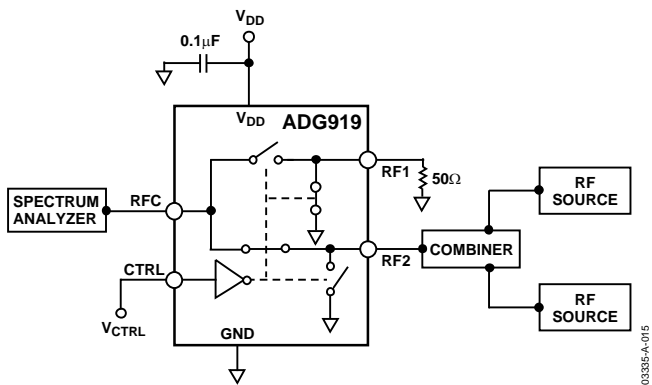

Figure 24. IP_3

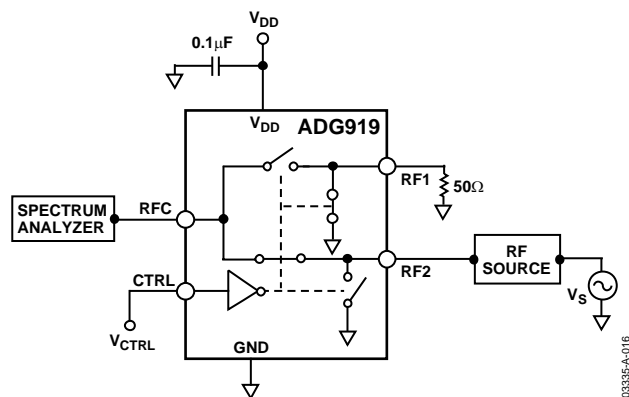

Figure 25. P_{-1dB}

* Similar setups for ADG918

APPLICATIONS

The ADG918/ADG919 are ideal solutions for low power, high frequency applications. The low insertion loss, high isolation between ports, low distortion, and low current consumption of these parts make them excellent solutions for many high frequency switching applications. The most obvious application is in a transmit/receive block, as shown in the wireless metering block diagram in Figure 26.

Other applications include switching between high frequency filters, ASK generator, FSK generator, and antenna diversity switch in many tuner modules.

ABSORPTIVE VS. REFLECTIVE

The ADG918 is an absorptive (matched) switch with $50\ \Omega$ terminated shunt legs, and the ADG919 is a reflective switch with $0\ \Omega$ terminated shunts to ground. The ADG918 absorptive switch has a good VSWR on each port, regardless of the switch mode. An absorptive switch should be used when there is a need for a good VSWR that is looking into the port but not passing the through signal to the common port. The ADG918 is therefore ideal for applications that require minimum reflections back to the RF source. It also ensures that the maximum power is transferred to the load.

The ADG919 reflective switch is suitable for applications where high off port VSWR does not matter and the switch has some other desired performance feature. It can be used in many applications, including high speed filter selection. In most cases, an absorptive switch can be used instead of a reflective switch, but not vice versa.

WIRELESS METERING

The ADG918 can be used in wireless metering applications. It can be used in conjunction with the ADF7020 transceiver IC for a utility metering transceiver application, providing the

required isolation between the transmit and receive signals. The SPDT configuration isolates the high frequency receive signal from the high frequency transmit.

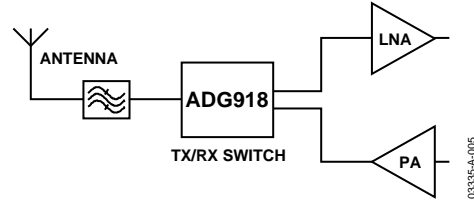

Figure 26. Wireless Metering

TUNER MODULES

The ADG918 can be used in a tuner module to switch between the cable TV input and the off-air antenna.

This part is also ideal for use as an antenna diversity switch, switching different antenna to the tuner.

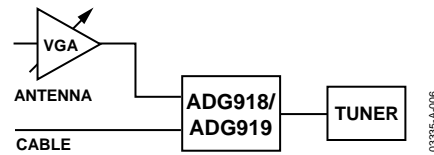

Figure 27. Tuner Modules

FILTER SELECTION

The ADG919 can be used as a 2:1 demultiplex to switch high frequency signals between different filters and also to multiplex the signal to the output.

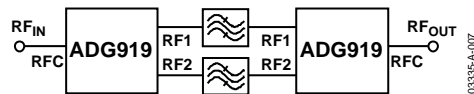

Figure 28. Filter Selection

ADG9XX EVALUATION BOARD

The ADG9xx evaluation board allows designers to evaluate the high performance wideband switches with a minimum of effort.

To prove that these devices meet the user's requirements, the user only requires a power supply and a network analyzer along with the evaluation board. An application note is available with the evaluation board and gives complete information on operating the evaluation board.

The RFC port (see Figure 29) is connected through a 50 Ω transmission line to the top left SMA connector J1. RF1 and RF2 are connected through 50 Ω transmission lines to the top two SMA connectors J2 and J3, respectively. A through transmission line connects J4 and J5 and this transmission line is used to estimate the loss of the PCB over the environmental conditions being evaluated.

The board is constructed of a 4-layer, FR4 material with a dielectric constant of 4.3 and an overall thickness of 0.062 inches. Two ground layers with grounded planes provide ground for the RF transmission lines. The transmission lines were designed using a coplanar waveguide with ground plane model using a trace width of 0.052 inches, clearance to ground plane of 0.030 inches, dielectric thickness of 0.029 inches, and a metal thickness of 0.014 inches.

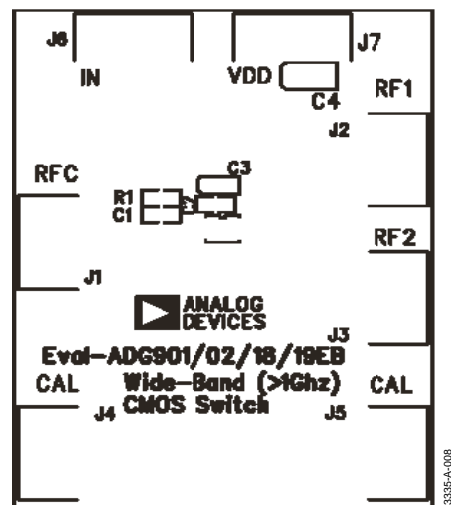

Figure 29. ADG9xx Evaluation Board Top View

OUTLINE DIMENSIONS

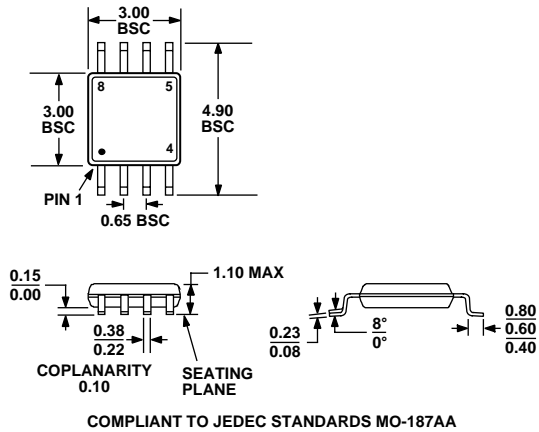

Figure 30. 8-Lead Mini Small Outline Package [MSOP]
(RM-8)
Dimensions shown in millimeters

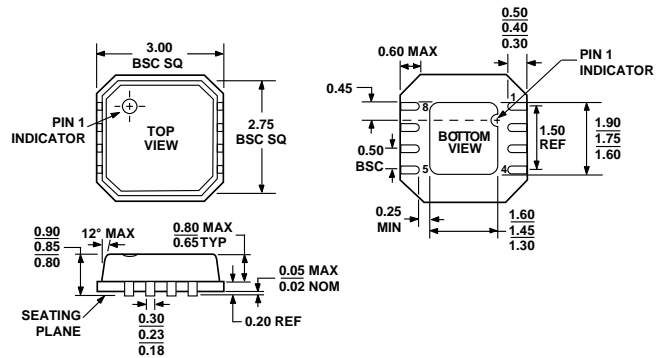

Figure 31. 8-Lead Lead Frame Chip Scale Package [LFCSP]
3 mm x 3 mm Body
(CP-8)
Dimensions shown in millimeters

ORDERING GUIDE

Model	Temperature Range	Package Description	Package Option	Branding
ADG918BRM	-40°C to +85°C	Mini Small Outline Package (MSOP)	RM-8	W4B
ADG918BRM-500RL7	-40°C to +85°C	Mini Small Outline Package (MSOP)	RM-8	W4B
ADG918BRM-REEL	-40°C to +85°C	Mini Small Outline Package (MSOP)	RM-8	W4B
ADG918BRM-REEL7	-40°C to +85°C	Mini Small Outline Package (MSOP)	RM-8	W4B
ADG918BRMZ ¹	-40°C to +85°C	Mini Small Outline Package (MSOP)	RM-8	W4C
ADG918BRMZ-REEL ¹	-40°C to +85°C	Mini Small Outline Package (MSOP)	RM-8	W4C
ADG918BRMZ-REEL7 ¹	-40°C to +85°C	Mini Small Outline Package (MSOP)	RM-8	W4C
ADG918BCP-500RL7	-40°C to +85°C	Lead Frame Chip Scale Package (LFCSP)	CP-8	W4B
ADG918BCP-REEL7	-40°C to +85°C	Lead Frame Chip Scale Package (LFCSP)	CP-8	W4B
ADG919BRM	-40°C to +85°C	Mini Small Outline Package (MSOP)	RM-8	W5B
ADG919BRM-500RL7	-40°C to +85°C	Mini Small Outline Package (MSOP)	RM-8	W5B
ADG919BRM-REEL	-40°C to +85°C	Mini Small Outline Package (MSOP)	RM-8	W5B
ADG919BRM-REEL7	-40°C to +85°C	Mini Small Outline Package (MSOP)	RM-8	W5B
ADG919BCP-500RL7	-40°C to +85°C	Lead Frame Chip Scale Package (LFCSP)	CP-8	W5B
ADG919BCP-REEL7	-40°C to +85°C	Lead Frame Chip Scale Package (LFCSP)	CP-8	W5B
EVAL-ADG918EB		Evaluation Board		
EVAL-ADG919EB		Evaluation Board		

¹Z = Pb-free part.

NOTES

NOTES



LittleDiode supplies new, hard to find or obsolete electronic components and semiconductors all over the world.

With over two million different components listed you are sure to find the part you need.

Feel free to visit us today at our online store:

LittleDiode.com

Looking forward to providing you with the best possible service.