

### FEATURES

#### Laser Trimmed to High Accuracy:

5.000 V  $\pm$  2.0 mV (M Grade)

#### Trimmed Temperature Coefficient:

2 ppm/ $^{\circ}$ C Max, 0 $^{\circ}$ C to 70 $^{\circ}$ C (M Grade)

5 ppm/ $^{\circ}$ C Max, -40 $^{\circ}$ C to +85 $^{\circ}$ C (B and L Grades)

10 ppm/ $^{\circ}$ C Max, -55 $^{\circ}$ C to +125 $^{\circ}$ C (T Grade)

#### Low Noise, 100 nV/ $\sqrt{\text{Hz}}$

#### Noise Reduction Capability

#### Output Trim Capability

#### MIL-STD-883-Compliant Versions Available

#### Industrial Temperature Range SOICs Available

#### Output Capable of Sourcing or Sinking 10 mA

### PRODUCT DESCRIPTION

The AD586 represents a major advance in the state-of-the-art in monolithic voltage references. Using a proprietary ion-implanted buried Zener diode and laser wafer trimming of high stability thin-film resistors, the AD586 provides outstanding performance at low cost.

The AD586 offers much higher performance than most other 5 V references. Because the AD586 uses an industry standard pinout, many systems can be upgraded instantly with the AD586. The buried Zener approach to reference design provides lower noise and drift than bandgap voltage references. The AD586 offers a noise reduction pin which can be used to further reduce the noise level generated by the buried Zener.

The AD586 is recommended for use as a reference for 8-, 10-, 12-, 14-, or 16-bit D/A converters which require an external precision reference. The device is also ideal for successive approximation or integrating A/D converters with up to 14 bits of accuracy and, in general, can offer better performance than the standard on-chip references.

The AD586J, K, L, and M are specified for operation from 0 $^{\circ}$ C to 70 $^{\circ}$ C, the AD586A and B are specified for -40 $^{\circ}$ C to +85 $^{\circ}$ C operation, and the AD586S and T are specified for -55 $^{\circ}$ C to +125 $^{\circ}$ C operation. The AD586J, K, L, and M are available in an 8-lead plastic DIP. The AD586J, K, L, A, and B are available in an 8-lead plastic surface mount small outline (SO) package. The AD586J, K, L, S, and T are available in an 8-lead cerdip package.

### REV. D

Information furnished by Analog Devices is believed to be accurate and reliable. However, no responsibility is assumed by Analog Devices for its use, nor for any infringements of patents or other rights of third parties which may result from its use. No license is granted by implication or otherwise under any patent or patent rights of Analog Devices.

### FUNCTIONAL BLOCK DIAGRAM

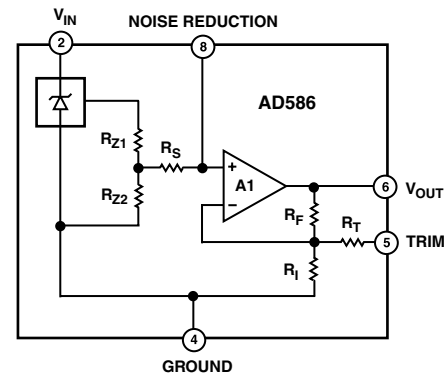

NOTE: PINS 1, 3, AND 7 ARE INTERNAL TEST POINTS.  
MAKE NO CONNECTIONS TO THESE POINTS.

### PRODUCT HIGHLIGHTS

1. Laser trimming of both initial accuracy and temperature coefficients results in very low errors over temperature without the use of external components. The AD586M has a maximum deviation from 5.000 V of  $\pm$ 2.45 mV between 0 $^{\circ}$ C and 70 $^{\circ}$ C, and the AD586T guarantees  $\pm$ 7.5 mV maximum total error between -55 $^{\circ}$ C and +125 $^{\circ}$ C.
2. For applications requiring higher precision, an optional fine-trim connection is provided.
3. Any system using an industry standard pinout reference can be upgraded instantly with the AD586.
4. Output noise of the AD586 is very low, typically 4  $\mu$ V p-p. A noise reduction pin is provided for additional noise filtering using an external capacitor.
5. The AD586 is available in versions compliant with MIL-STD-883. Refer to the Analog Devices Military Products Databook or current AD586/883B data sheet for detailed specifications.

# AD586—SPECIFICATIONS (@ $T_A = 25^\circ\text{C}$ , $V_{IN} = 15\text{ V}$ unless otherwise noted.)

Model	AD586J			AD586K/A			AD586L/B			AD586M			AD586S			AD586T			Unit
	Min	Typ	Max	Min	Typ	Max	Min	Typ	Max	Min	Typ	Max	Min	Typ	Max	Min	Typ	Max	
Output Voltage	<b>4.980</b>		<b>5.020</b>	<b>4.995</b>		<b>5.005</b>	<b>4.9975</b>		<b>5.0025</b>	<b>4.998</b>		<b>5.002</b>	<b>4.990</b>		<b>5.010</b>	<b>4.9975</b>		<b>5.0025</b>	V
Output Voltage Drift <sup>1</sup> 0°C to 70°C -55°C to +125°C			<b>25</b>			<b>15</b>			<b>5</b>			<b>2</b>			<b>20</b>			<b>10</b>	ppm/°C ppm/°C
Gain Adjustment	<b>+6</b> <b>-2</b>			<b>+6</b> <b>-2</b>			<b>+6</b> <b>-2</b>			<b>+6</b> <b>-2</b>			<b>+6</b> <b>-2</b>			<b>+6</b> <b>-2</b>			% %
Line Regulation <sup>1</sup> 10.8 V < $V_{IN}$ < 36 V $T_{MIN}$ to $T_{MAX}$ 11.4 V < $V_{IN}$ < 36 V $T_{MIN}$ to $T_{MAX}$			<b>100</b>			<b>100</b>			<b>100</b>			<b>100</b>			<b>150</b>			<b>150</b>	$\pm\mu\text{V/V}$ $\pm\mu\text{V/V}$
Load Regulation <sup>1</sup> Sourcing 0 < $I_{OUT}$ < 10 mA 25°C $T_{MIN}$ to $T_{MAX}$ Sinking -10 < $I_{OUT}$ < 0 mA 25°C			<b>100</b> <b>100</b>			<b>100</b> <b>100</b>			<b>100</b> <b>100</b>			<b>100</b> <b>100</b>			<b>150</b> <b>150</b>			<b>150</b> <b>150</b>	$\mu\text{V/mA}$ $\mu\text{V/mA}$ $\mu\text{V/mA}$
Quiescent Current		<b>2</b>	<b>3</b>		<b>2</b>	<b>3</b>		<b>2</b>	<b>3</b>		<b>2</b>	<b>3</b>		<b>2</b>	<b>3</b>		<b>2</b>	<b>3</b>	mA
Power Consumption			<b>30</b>			<b>30</b>			<b>30</b>			<b>30</b>			<b>30</b>			<b>30</b>	mW
Output Noise 0.1 Hz to 10 Hz Spectral Density, 100 Hz			<b>4</b> <b>100</b>			<b>4</b> <b>100</b>			<b>4</b> <b>100</b>			<b>4</b> <b>100</b>			<b>4</b> <b>100</b>			<b>4</b> <b>100</b>	$\mu\text{V}_{\text{p-p}}$ $\text{nV}/\sqrt{\text{Hz}}$
Long-Term Stability			<b>15</b>			<b>15</b>			<b>15</b>			<b>15</b>			<b>15</b>			<b>15</b>	ppm/1000 Hr
Short-Circuit Current-to-Ground		<b>45</b>	<b>60</b>		<b>45</b>	<b>60</b>		<b>45</b>	<b>60</b>		<b>45</b>	<b>60</b>		<b>45</b>	<b>60</b>		<b>45</b>	<b>60</b>	mA
Temperature Range Specified Performance <sup>2</sup> Operating Performance <sup>3</sup>		<b>0</b>	<b>70</b>		<b>0</b>	<b>70</b>		<b>0</b>	<b>70</b>		<b>0</b>	<b>70</b>		<b>-55</b>	<b>+125</b>		<b>-55</b>	<b>+125</b>	°C °C °C

## NOTES

<sup>1</sup>Maximum output voltage drift is guaranteed for all packages and grades. Cerdip packaged parts are also 100°C production tested.

<sup>2</sup>Lower row shows specified performance for A and B grades.

<sup>3</sup>The operating temperature range is defined as the temperatures extremes at which the device will still function. Parts may deviate from their specified performance outside their specified temperature range.

Specifications subject to change without notice.

Specifications in **boldface** are rested on all production units at final electrical test. Results from those tests are used to calculate outgoing quality levels. All min and max specifications are guaranteed, although only those shown in boldface are tested on all production units unless otherwise specified.

## ABSOLUTE MAXIMUM RATINGS\*

$V_{IN}$  to Ground . . . . . 36 V

Power Dissipation (25°C) . . . . . 500 mW

Storage Temperature . . . . . -65°C to +150°C

Lead Temp (Soldering, 10 sec) . . . . . 300°C

Package Thermal Resistance

$\theta_{JC}$  . . . . . 22°C/W

$\theta_{JA}$  . . . . . 110°C/W

Output Protection: Output safe for indefinite short to ground or  $V_{IN}$ .

\*Stresses above those listed under Absolute Maximum Ratings may cause permanent damage to the device. This is a stress rating only; functional operation of the device at these or any other conditions above those indicated in the operational section of this specification is not implied. Exposure to absolute maximum rating conditions for extended periods may affect device reliability.

## CONNECTION DIAGRAM (Top View)

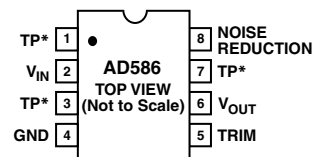

\*TP DENOTES FACTORY TEST POINT.  
NO CONNECTIONS, EXCEPT DUMMY PCB PAD,  
SHOULD BE MADE TO THESE POINTS.

## DIE SPECIFICATIONS

The following specifications are tested at the dice level for AD586JCHIPS. These die are probed at 25°C only. ( $T_A = 25^\circ\text{C}$ ,  $V_{IN} = 15\text{ V}$  unless otherwise noted.)

Parameter	AD586JCHIPS			Unit
	Min	Typ	Max	
Output Voltage	4.980		5.020	V
Gain Adjustment	+6			%
	-2			%
Line Regulation 10.8 V < $V_{IN}$ < 36 V			100	$\pm\mu\text{V/V}$
Load Regulation				
Sourcing $0 < I_{OUT} < 10\text{ mA}$			100	$\mu\text{V/mA}$
Sinking $-10 < I_{OUT} < 0\text{ mA}$			400	$\mu\text{V/mA}$
Quiescent Current			3	mA
Short-Circuit Current-to-Ground			60	mA

### NOTES

<sup>1</sup>Both  $V_{OUT}$  pads should be connected to the output.

**Die Thickness:** The standard thickness of Analog Devices Bipolar dice is 24 mils  $\pm 2$  mils.

**Die Dimensions:** The dimensions given have a tolerance of  $\pm 2$  mils.

**Backing:** The standard backside surface is silicon (not plated). Analog Devices does not recommend gold-backed dice for most applications.

**Edges:** A diamond saw is used to separate wafers into dice thus providing perpendicular edges halfway through the die.

In contrast to scribed dice, this technique provides a more uniform die shape and size. The perpendicular edges facilitate handling (such as tweezer pick-up) while the uniform shape and size simplifies substrate design and die attach.

**Top Surface:** The standard top surface of the die is covered by a layer of glassivation. All areas are covered except bonding pads and scribe lines.

**Surface Metalization:** The metalization to Analog Devices bipolar dice is aluminum. Minimum thickness is 10,000Å.

**Bonding Pads:** All bonding pads have a minimum size of 4 mils by 4 mils. The passivation windows have 3.5 mils by 3.5 mils minimum.

### DIE LAYOUT

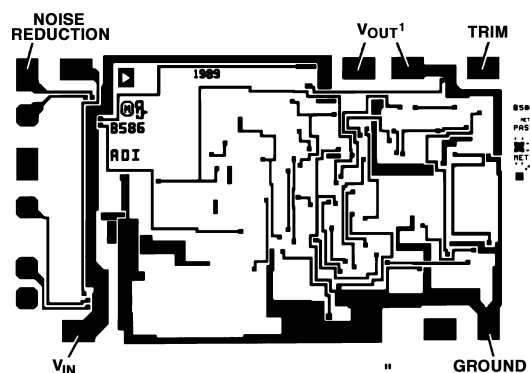

Die Size: 0.096 × 0.061 Inches

### ORDERING GUIDE

Model*	Initial Error	Temperature Coefficient	Temperature Range	Package Description	Package Option
AD586JN	20 mV	25 ppm/°C	0°C to 70°C	Plastic DIP	N-8
AD586JQ	20 mV	25 ppm/°C	0°C to 70°C	Cerdip	Q-8
AD586JR	20 mV	25 ppm/°C	0°C to 70°C	SOIC	SO-8
AD586KN	5 mV	15 ppm/°C	0°C to 70°C	Plastic DIP	N-8
AD586KQ	5 mV	15 ppm/°C	0°C to 70°C	Cerdip	Q-8
AD586KR	5 mV	15 ppm/°C	0°C to 70°C	SOIC	SO-8
AD586LN	2.5 mV	5 ppm/°C	0°C to 70°C	Plastic DIP	N-8
AD586LR	2.5 mV	5 ppm/°C	0°C to 70°C	SOIC	SO-8
AD586MN	2 mV	2 ppm/°C	0°C to 70°C	Plastic DIP	N-8
AD586AR	5 mV	15 ppm/°C	-40°C to +85°C	SOIC	SO-8
AD586BR	2.5 mV	5 ppm/°C	-40°C to +85°C	SOIC	SO-8
AD586LQ	2.5 mV	5 ppm/°C	0°C to 70°C	Cerdip	Q-8
AD586SQ	10 mV	20 ppm/°C	-55°C to +125°C	Cerdip	Q-8
AD586TQ	2.5 mV	10 ppm/°C	-55°C to +125°C	Cerdip	Q-8
AD586JCHIPS	20 mV	25 ppm/°C	0°C to 70°C		

\*For details on grade and package offerings screened in accordance with MIL-STD-883, refer to the Analog Devices Military Products Databook or current AD586/883B data sheet.

### CAUTION

ESD (electrostatic discharge) sensitive device. Electrostatic charges as high as 4000 V readily accumulate on the human body and test equipment and can discharge without detection. Although the AD586 features proprietary ESD protection circuitry, permanent damage may occur on devices subjected to high-energy electrostatic discharges. Therefore, proper ESD precautions are recommended to avoid performance degradation or loss of functionality.



# AD586

## THEORY OF OPERATION

The AD586 consists of a proprietary buried Zener diode reference, an amplifier to buffer the output and several high stability thin-film resistors as shown in the block diagram in Figure 1. This design results in a high precision monolithic 5 V output reference with initial offset of 2.0 mV or less. The temperature compensation circuitry provides the device with a temperature coefficient of under 2 ppm/°C.

Using the bias compensation resistor between the Zener output and the noninverting input to the amplifier, a capacitor can be added at the NOISE REDUCTION pin (Pin 8) to form a low-pass filter and reduce the noise contribution of the Zener to the circuit.

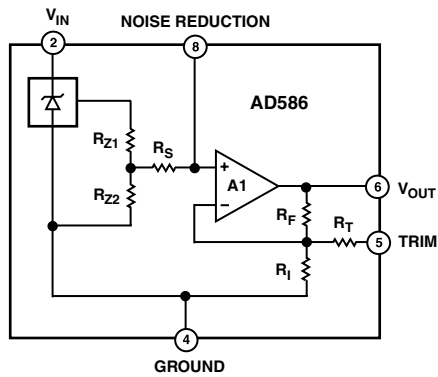

NOTE: PINS 1, 3, AND 7 ARE INTERNAL TEST POINTS. MAKE NO CONNECTIONS TO THESE POINTS.

Figure 1. Functional Block Diagram

## APPLYING THE AD586

The AD586 is simple to use in virtually all precision reference applications. When power is applied to Pin 2 and Pin 4 is grounded, Pin 6 provides a 5 V output. No external components are required; the degree of desired absolute accuracy is achieved simply by selecting the required device grade. The AD586 requires less than 3 mA quiescent current from an operating supply of 12 V or 15 V.

An external fine trim may be desired to set the output level to exactly 5.000 V (calibrated to a main system reference). System calibration may also require a reference voltage that is slightly different from 5.000 V, for example, 5.12 V for binary applications. In either case, the optional trim circuit shown in Figure 2 can offset the output by as much as 300 mV, if desired, with minimal effect on other device characteristics.

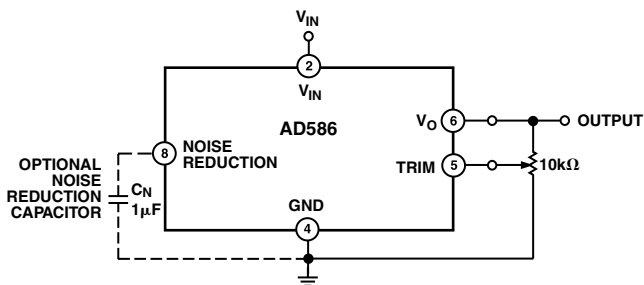

Figure 2. Optional Fine Trim Configuration

## NOISE PERFORMANCE AND REDUCTION

The noise generated by the AD586 is typically less than 4 μV p-p over the 0.1 Hz to 10 Hz band. Noise in a 1 MHz bandwidth is approximately 200 μV p-p. The dominant source of this noise is the buried Zener which contributes approximately 100 nV/√Hz. In comparison, the op amp's contribution is negligible. Figure 3 shows the 0.1 Hz to 10 Hz noise of a typical AD586. The noise measurement is made with a bandpass filter made of a 1-pole high-pass filter with a corner frequency at 0.1 Hz and a 2-pole low-pass filter with a corner frequency at 12.6 Hz to create a filter with a 9.922 Hz bandwidth.

If further noise reduction is desired, an external capacitor may be added between the NOISE REDUCTION pin and ground as shown in Figure 2. This capacitor, combined with the 4 kΩ R<sub>S</sub> and the Zener resistances form a low-pass filter on the output of the Zener cell. A 1 μF capacitor will have a 3 dB point at 12 Hz, and it will reduce the high frequency (to 1 MHz) noise to about 160 μV p-p. Figure 4 shows the 1 MHz noise of a typical AD586 both with and without a 1 μF capacitor.

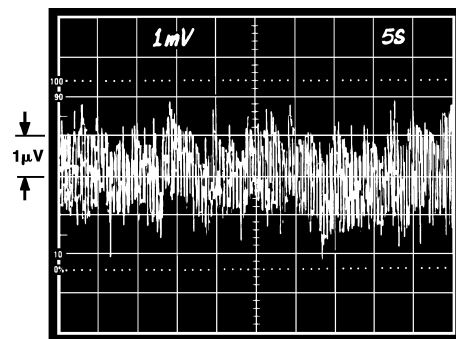

Figure 3. 0.1 Hz to 10 Hz Noise

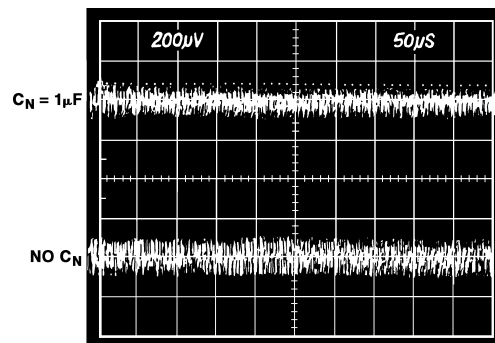
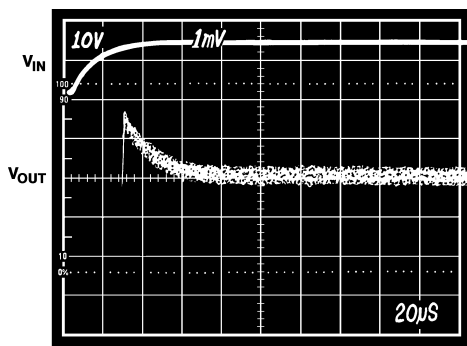

Figure 4. Effect of 1 μF Noise Reduction Capacitor on Broadband Noise

**TURN-ON TIME**

Upon application of power (cold start), the time required for the output voltage to reach its final value within a specified error band is defined as the turn-on settling time. Two components normally associated with this are: the time for the active circuits to settle, and the time for the thermal gradients on the chip to stabilize. Figure 5 shows the turn-on characteristics of the AD586. It shows the settling to be about 60  $\mu$ s to 0.01%. Note the absence of any thermal tails when the horizontal scale is expanded to 1 ms/cm in Figure 5b.

Output turn-on time is modified when an external noise reduction capacitor is used. When present, this capacitor acts as an additional load to the internal Zener diode's current source, resulting in a somewhat longer turn-on time. In the case of a 1  $\mu$ F capacitor, the initial turn-on time is approximately 400 ms to 0.01% (see Figure 5c).



a. Electrical Turn-On

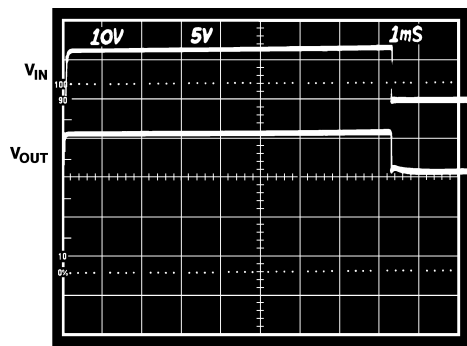

b. Extended Time Scale

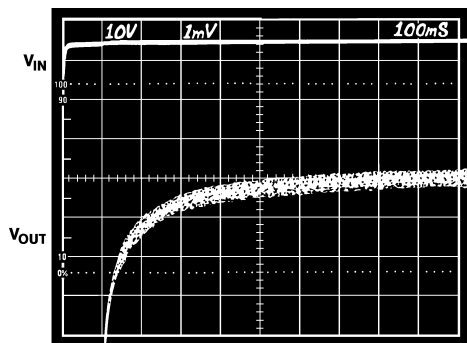

c. Turn-On with 1  $\mu$ F  $C_N$

Figure 5. Turn-On Characteristics

**DYNAMIC PERFORMANCE**

The output buffer amplifier is designed to provide the AD586 with static and dynamic load regulation superior to less complete references.

Many A/D and D/A converters present transient current loads to the reference, and poor reference response can degrade the converter's performance.

Figure 6 displays the characteristics of the AD586 output amplifier driving a 0 mA to 10 mA load.

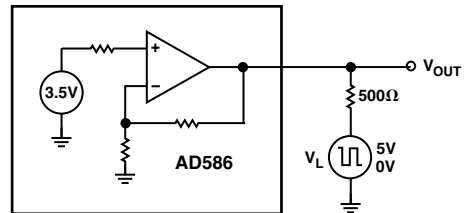

Figure 6a. Transient Load Test Circuit

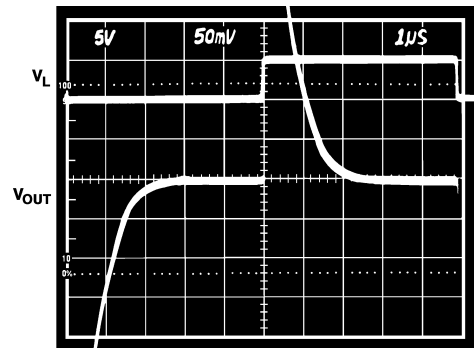

Figure 6b. Large-Scale Transient Response

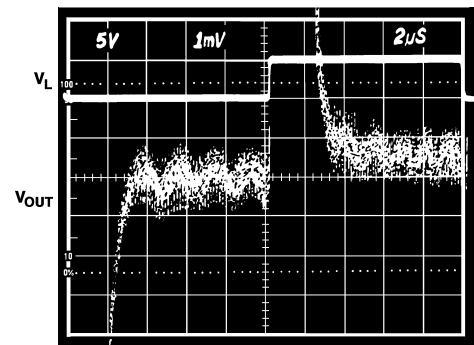

Figure 6c. Fine-Scale Setting for Transient Load

# AD586

In some applications, a varying load may be both resistive and capacitive in nature, or the load may be connected to the AD586 by a long capacitive cable.

Figure 7 displays the output amplifier characteristics driving a 1000 pF, 0 to 10 mA load.

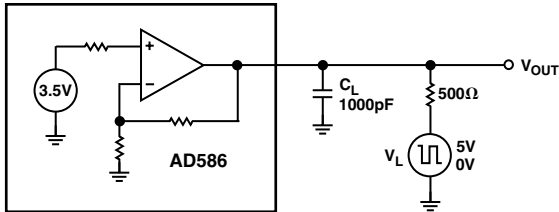

Figure 7a. Capacitive Load Transient Response Test Circuit

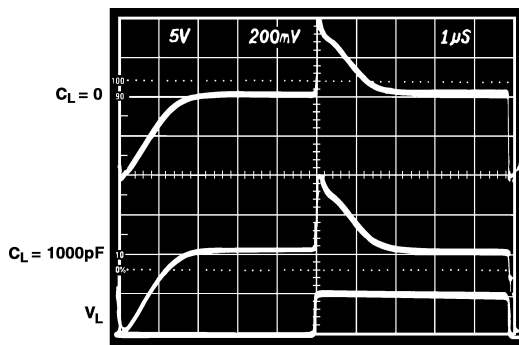

Figure 7b. Output Response with Capacitive Load

## LOAD REGULATION

The AD586 has excellent load regulation characteristics. Figure 8 shows that varying the load several mA changes the output by a few  $\mu\text{V}$ . The AD586 has somewhat better load regulation performance sourcing current than sinking current.

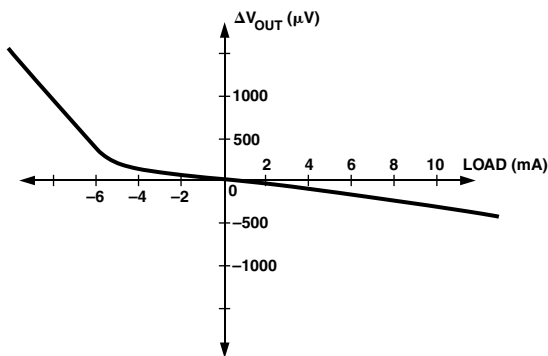

Figure 8. Typical Load Regulation Characteristics

## TEMPERATURE PERFORMANCE

The AD586 is designed for precision reference applications where temperature performance is critical. Extensive temperature testing ensures that the device's high level of performance is maintained over the operating temperature range.

Some confusion exists in the area of defining and specifying reference voltage error over temperature. Historically, references have been characterized using a maximum deviation per degree

Centigrade; i.e., ppm/ $^{\circ}\text{C}$ . However, because of nonlinearities in temperature characteristics which originated in standard Zener references (such as "S" type characteristics), most manufacturers have begun to use a maximum limit error band approach to specify devices. This technique involves the measurement of the output at three or more different temperatures to specify an output voltage error band.

Figure 9 shows the typical output voltage drift for the AD586L and illustrates the test methodology. The box in Figure 9 is bounded on the sides by the operating temperature extremes, and on the top and the bottom by the maximum and minimum output voltages measured over the operating temperature range. The slope of the diagonal drawn from the lower left to the upper right corner of the box determines the performance grade of the device.

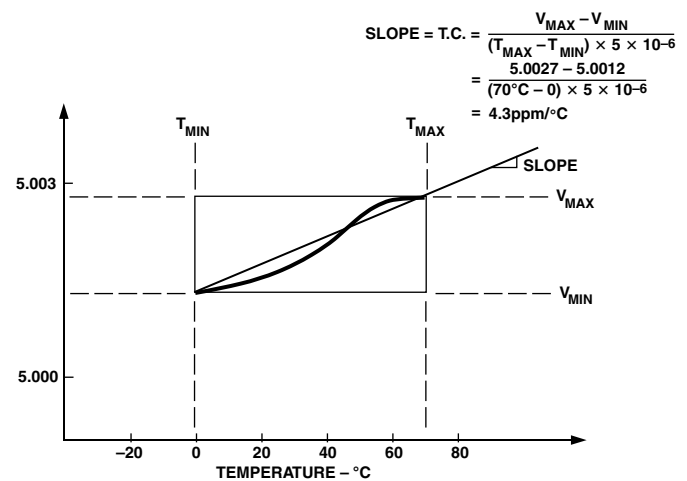

Figure 9. Typical AD586L Temperature Drift

Each AD586J, K and L grade unit is tested at 0 $^{\circ}\text{C}$ , 25 $^{\circ}\text{C}$ , and 70 $^{\circ}\text{C}$ . Each AD586SQ and TQ grade unit is tested at -5 $^{\circ}\text{C}$ , +25 $^{\circ}\text{C}$ , and +125 $^{\circ}\text{C}$ . This approach ensures that the variations of output voltage that occur as the temperature changes within the specified range will be contained within a box whose diagonal has a slope equal to the maximum specified drift. The position of the box on the vertical scale will change from device to device as initial error and the shape of the curve vary. The maximum height of the box for the appropriate temperature range and device grade is shown in Table I. Duplication of these results requires a combination of high accuracy and stable temperature control in a test system. Evaluation of the AD586 will produce a curve similar to that in Figure 9, but output readings may vary depending on the test methods and equipment utilized.

Table I. Maximum Output Change in mV

Device Grade	Maximum Output Change (mV)		
	0 $^{\circ}\text{C}$ to 70 $^{\circ}\text{C}$	-40 $^{\circ}\text{C}$ to +85 $^{\circ}\text{C}$	-55 $^{\circ}\text{C}$ to +125 $^{\circ}\text{C}$
AD586J	8.75		
AD586K	5.25		
AD586L	1.75		
AD586M	0.70		
AD586A		9.37	
AD586B		3.12	
AD586S			18.00
AD586T			9.00

## NEGATIVE REFERENCE VOLTAGE FROM AN AD586

The AD586 can be used to provide a precision  $-5.000\text{ V}$  output as shown in Figure 10. The  $V_{IN}$  pin is tied to at least a  $6\text{ V}$  supply, the output pin is grounded, and the AD586 ground pin is connected through a resistor,  $R_S$ , to a  $-15\text{ V}$  supply. The  $-5\text{ V}$  output is now taken from the ground pin (Pin 4) instead of  $V_{OUT}$ . It is essential to arrange the output load and the supply resistor  $R_S$  so that the net current through the AD586 is between  $2.5\text{ mA}$  and  $10.0\text{ mA}$ . The temperature characteristics and long-term stability of the device will be essentially the same as that of a unit used in the standard  $5\text{ V}$  output configuration.

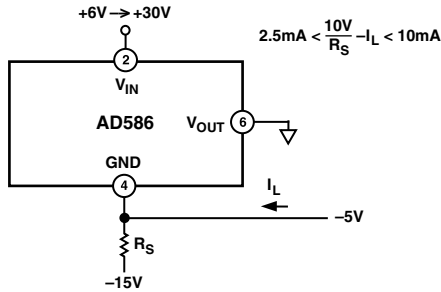

Figure 10. AD586 as a Negative 5 V Reference

## USING THE AD586 WITH CONVERTERS

The AD586 is an ideal reference for a wide variety of 8-, 12-, 14-, and 16-bit A/D and D/A converters. Several representative examples follow.

### 5 V REFERENCE WITH MULTIPLYING CMOS D/A OR A/D CONVERTERS

The AD586 is ideal for applications with 10- and 12-bit multiplying CMOS D/A converters. In the standard hookup, as shown in Figure 11, the AD586 is paired with the AD7545 12-bit multiplying DAC and the AD711 high-speed BiFET Op Amp. The amplifier DAC configuration produces a unipolar  $0\text{ V}$  to  $-5\text{ V}$  output range. Bipolar output applications and other operating details can be found on the individual product data sheets.

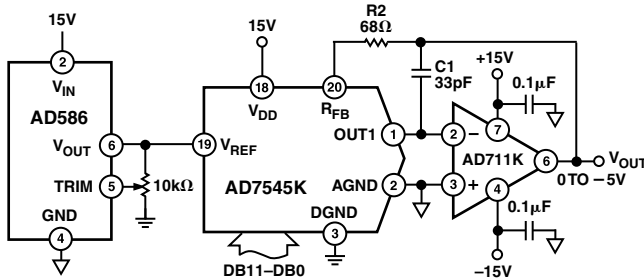

Figure 11. Low-Power 12-Bit CMOS DAC Application

The AD586 can also be used as a precision reference for multiple DACs. Figure 12 shows the AD586, the AD7628 dual DAC and the AD712 dual op amp hooked up for single supply operation to produce  $0\text{ V}$  to  $-5\text{ V}$  outputs. Because both DACs are on the same die and share a common reference and output op amps, the DAC outputs will exhibit similar gain TCs.

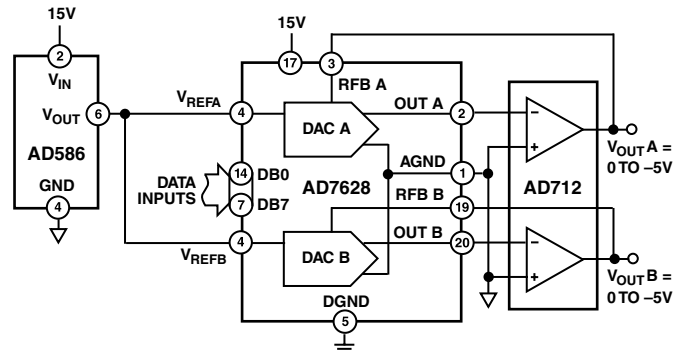

Figure 12. AD586 as a 5 V Reference for a CMOS Dual DAC

## STACKED PRECISION REFERENCES FOR MULTIPLE VOLTAGES

Often, a design requires several reference voltages. Three AD586s can be stacked, as shown in Figure 13, to produce  $5.000\text{ V}$ ,  $10.000\text{ V}$ , and  $15.000\text{ V}$  outputs. This scheme can be extended to any number of AD586s as long as the maximum load current is not exceeded. This design provides the additional advantage of improved line regulation on the  $5.0\text{ V}$  output. Changes in  $V_{IN}$  of  $18\text{ V}$  to  $50\text{ V}$  produces an output change that is below the noise level of the references.

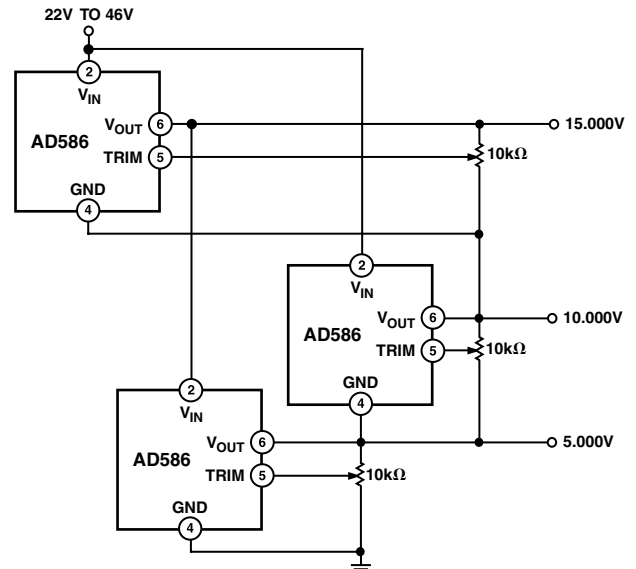

Figure 13. Multiple AD586s Stacked for Precision 5 V, 10 V, and 15 V Outputs

# AD586

## PRECISION CURRENT SOURCE

The design of the AD586 allows it to be easily configured as a current source. By choosing the control resistor  $R_C$  in Figure 14, you can vary the load current from the quiescent current (2 mA typically) to approximately 10 mA. The compliance voltage of this circuit varies from about 5 V to 21 V depending upon the value of  $V_{IN}$ .

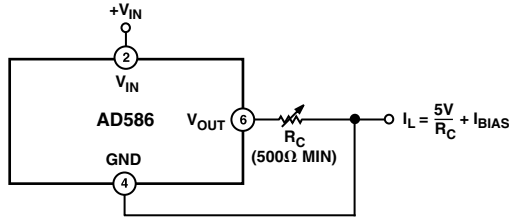

Figure 14. Precision Current Source

## PRECISION HIGH CURRENT SUPPLY

For higher currents, the AD586 can easily be connected to a power PNP or power Darlington PNP device. The circuit in Figure 15 can deliver up to 4 amps to the load. The 0.1  $\mu$ F capacitor is required only if the load has a significant capacitive component. If the load is purely resistive, improved high-frequency supply rejection results can be obtained by removing the capacitor.

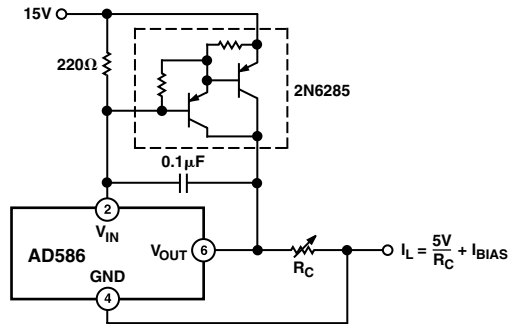

Figure 15a. Precision High-Current Current Source

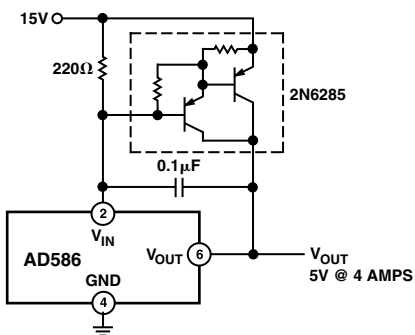
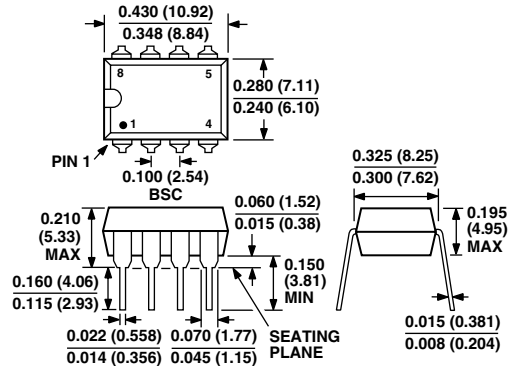

Figure 15b. Precision High-Current Voltage Source

## OUTLINE DIMENSIONS

Dimensions shown in inches and (mm.)

### Mini-DIP (N-8) Package



### Cerdip (Q-8) Package

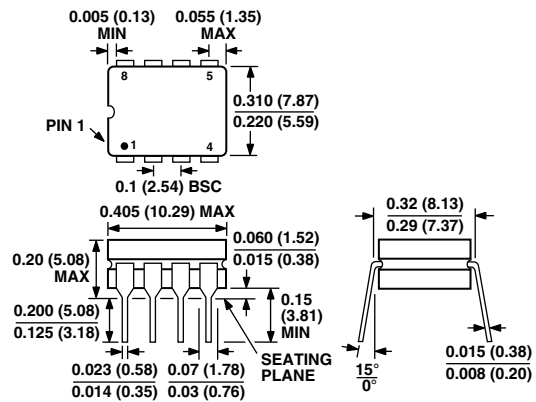

### Small Outline (SO-8) Package

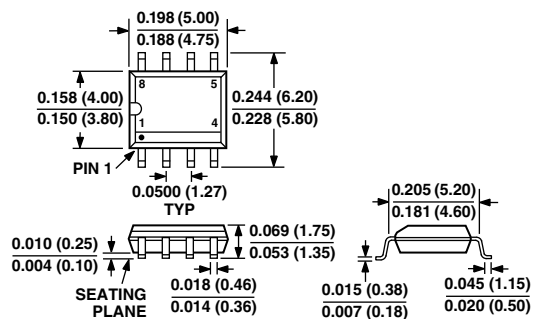

## AD586 Revision History

### Location

Data Sheet changed from REV. C to REV. D.

Changed Figure 10 to Table I (Maximum Output Change in mV) ..... 6



LittleDiode supplies new, hard to find or obsolete electronic components and semiconductors all over the world.

With over two million different components listed you are sure to find the part you need.

Feel free to visit us today at our online store:

[LittleDiode.com](http://LittleDiode.com)

Looking forward to providing you with the best possible service.