

## High Voltage EL Lamp Driver

### Ordering Information

Device	Input Voltage	Package Options	
		8-Lead SO	Die
HV830	2.0V to 9.5V	HV830LG	HV830X

### Features

- Processed with HVCMOS® technology
- 2.0V to 9.5V operating supply voltage
- DC to AC conversion
- 200V peak-to-peak typical output voltage
- Large output load capability – typically 50nF
- Permits the use of high-resistance elastomeric lamp connectors
- Adjustable output lamp frequency to control lamp color, lamp life, and power consumption
- Adjustable converter frequency to eliminate harmonics and optimize power consumption
- Enable/disable function
- Low current draw under no load condition
- Very low standby current – 30nA typical

### Applications

- Handheld personal computers
- Electronic personal organizers
- GPS units
- Pagers
- Cellular phones
- Portable instrumentation

### Absolute Maximum Ratings\*

Supply Voltage, $V_{DD}$	-0.5V to +10V
Output Voltage, $V_{Cs}$	-0.5V to +120V
Operating Temperature Range	-25°C to +85°C
Storage Temperature Range	-65°C to +150°C
Power Dissipation	400mW

**Note:**

\*All voltages are referenced to GND.

### General Description

The Supertex HV830 is a high-voltage driver designed for driving EL lamps of up to 50nF. EL lamps greater than 50nF can be driven for applications not requiring high brightness. The input supply voltage range is from 2.0V to 9.5V. The device uses a single inductor and a minimum number of passive components. The nominal regulated output voltage that is applied to the EL lamp is  $\pm 100V$ . The chip can be enabled by connecting the resistors on  $R_{SW-osc}$  and  $R_{EL-osc}$  to  $V_{DD}$  and disabled when connected to GND.

The HV830 has two internal oscillators, a switching MOSFET, and a high-voltage EL lamp driver. The frequency for the switching converter MOSFET is set by an external resistor connected between the  $R_{SW-osc}$  pin and the supply pin  $V_{DD}$ . The EL lamp driver frequency is set by an external resistor connected between  $R_{EL-osc}$  pin and the  $V_{DD}$  pin. An external inductor is connected between the  $L_x$  and  $V_{DD}$  pins. A 0.01 $\mu F$  to 0.1 $\mu F$  capacitor is connected between  $C_s$  and GND. The EL lamp is connected between  $V_A$  and  $V_B$ .

The switching MOSFET charges the external inductor and discharges it into the  $C_s$  capacitor. The voltage at  $C_s$  will start to increase. Once the voltage at  $C_s$  reaches a nominal value of 100V, the switching MOSFET is turned OFF to conserve power. The outputs  $V_A$  and  $V_B$  are configured as an H-bridge and are switched in opposite states to achieve 200V peak-to-peak across the EL lamp.

### Pin Configuration

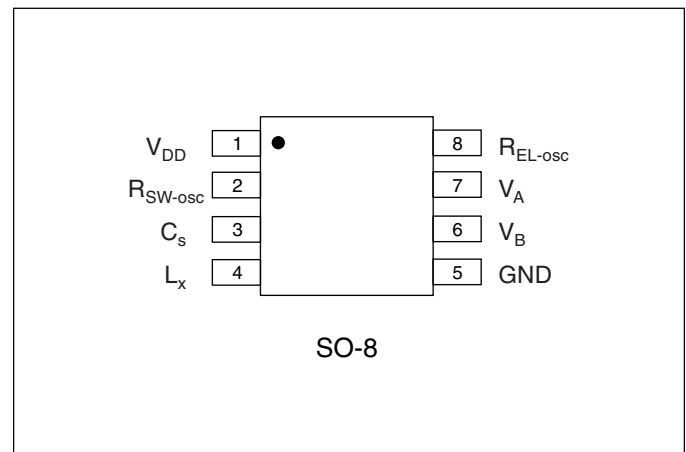

# Electrical Characteristics

**DC Characteristics** ( $V_{DD} = 3.0V$ ,  $R_{SW} = 1M\Omega$ ,  $R_{EL} = 3.3M\Omega$ ,  $T_A = 25^\circ C$  unless otherwise specified)

Symbol	Parameter	Min	Typ	Max	Units	Conditions
$R_{DS(on)}$	On-resistance of switching transistor		2	6	$\Omega$	$I = 100mA$
$V_{CS}$	Output voltage $V_{CS}$ Regulation	90	100	110	V	$V_{DD} = 2.0V$ to $9.5V$
$V_A - V_B$	Output peak to peak voltage	180	200	220	V	$V_{DD} = 2.0V$ to $9.5V$
$I_{DDQ}$	Quiescent $V_{DD}$ supply current, disabled		30		nA	$R_{SW-osc} = Low$
$I_{DD}$	Input current going into the $V_{DD}$ pin		100	150	$\mu A$	$V_{DD} = 3.0V$ . See Figure 1.
$I_{IN}$	Input current including inductor current		35	40	mA	$V_{DD} = 3.0V$ . See Figure 1.
$V_{CS}$	Output voltage on $V_{CS}$		95		V	$V_{DD} = 3.0V$ . See Figure 1.
$f_{EL}$	$V_{A-B}$ output drive frequency	220	250	280	Hz	$V_{DD} = 3.0V$ . See Figure 1.
$f_{SW}$	Switching transistor frequency	55	65	75	KHz	$V_{DD} = 3.0V$ . See Figure 1.
D	Switching transistor duty cycle		88		%	

## Recommended Operating Conditions

Symbol	Parameter	Min	Typ	Max	Units	Conditions
$V_{DD}$	Supply voltage	2.0		9.5	V	
$f_{EL}$	$V_{A-B}$ Output drive frequency			1.5	KHz	
$T_A$	Operating temperature	-25		+85	$^\circ C$	

## Enable/Disable Table (See Figure 2)

$R_{SW}$ resistor	HV830
$V_{DD}$	Enable
0V	Disable

## Block Diagram

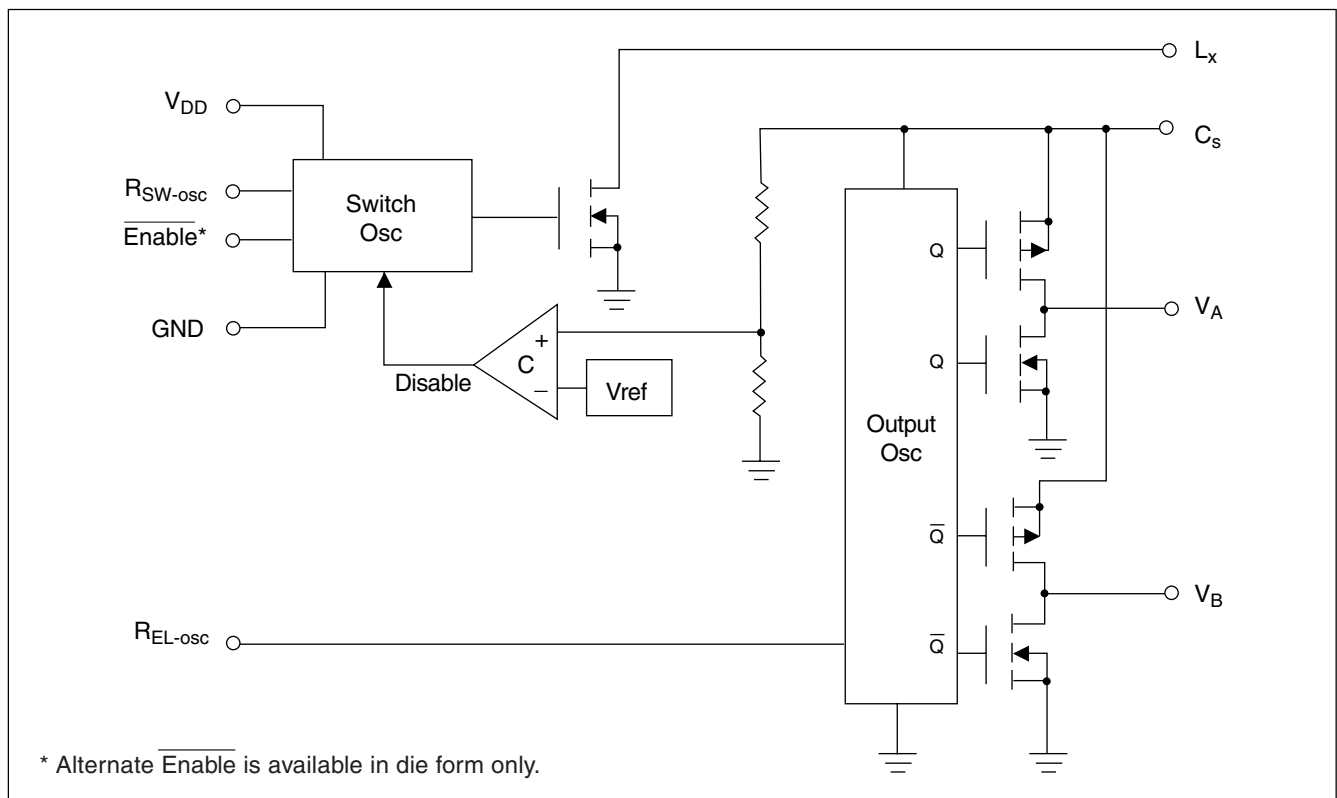

**Figure 1: Test Circuit,  $V_{IN} = 3.0V$**

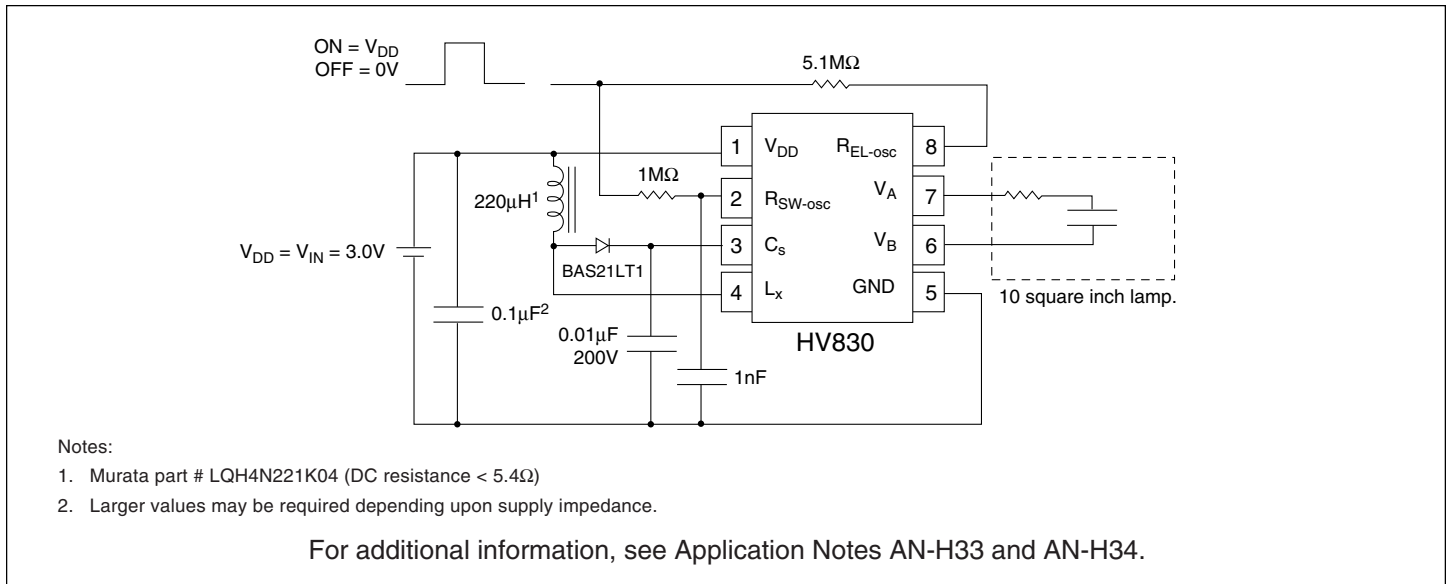

**Enable/Disable Configuration**

The HV830 can be easily enabled and disabled via a logic control signal on the  $R_{SW}$  and  $R_{EL}$  resistors as shown in Figure 2 below. The control signal can be from a microprocessor.  $R_{SW}$  and  $R_{EL}$  are typically very high values. Therefore, only 10's of microam-

peres will be drawn from the logic signal when it is at a logic high (enable) state. When the microprocessor signal is high the device is enabled and when the signal is low, it is disabled.

**Figure 2: Enable/Disable Configuration**

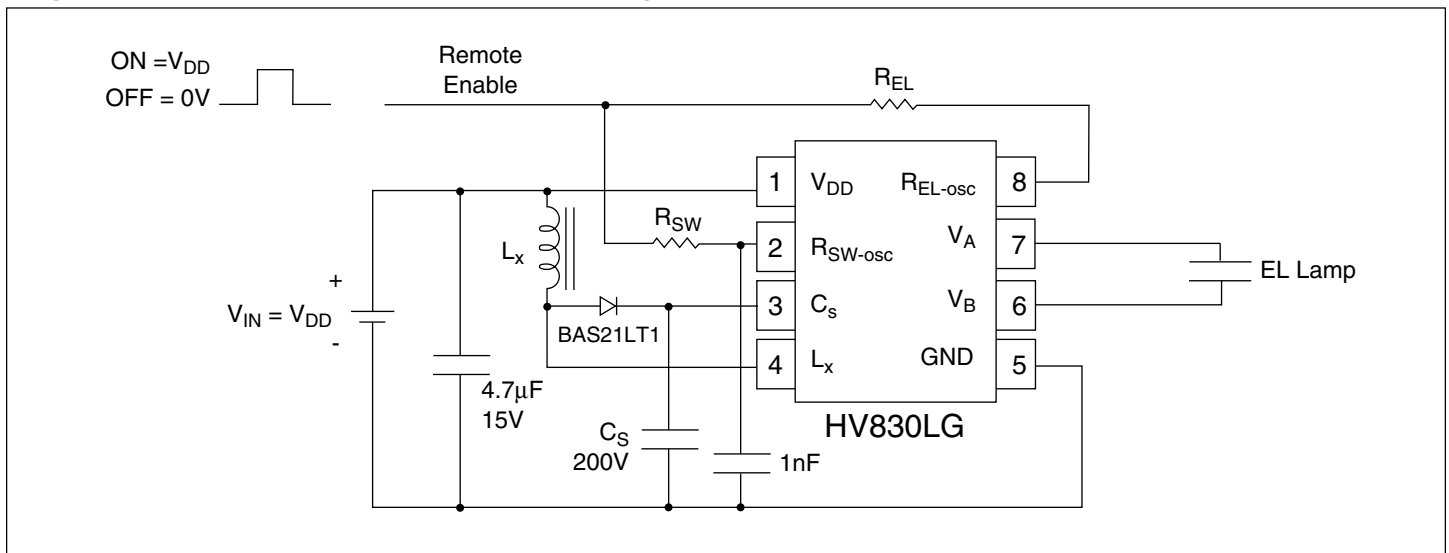

**Split Supply Configuration Using a Single Cell (1.5V) Battery**

The HV830 can also be used for handheld devices operating from a single cell 1.5V battery where a regulated voltage is available. This is shown in Figure 3. The regulated voltage can be used to run the internal logic of the HV830. The amount of current necessary to run the internal logic is typically 100μA at a  $V_{DD}$  of 3.0V. Therefore, the regulated voltage could easily provide the current without being loaded down. The HV830 used in this configuration can also be enabled/disabled via logic control signal on the  $R_{SW}$  and  $R_{EL}$  resistors as shown in Figure 2.

**Split Supply Configuration for Battery Voltages of Higher than 9.5V**

Figure 3 can also be used with high battery voltages such as 12V as long as the input voltage,  $V_{DD}$ , to the HV830 device is within its specifications of 2.0V to 9.5V.

## External Component Description

External Component	Selection Guide Line
Diode	Fast reverse recovery diode, BAS21LT1 or equivalent.
Cs Capacitor	0.01 $\mu$ F to 0.1 $\mu$ F, 200V capacitor to GND is used to store the energy transferred from the inductor.
R <sub>EL-osc</sub>	The EL lamp frequency is controlled via an external R <sub>EL</sub> resistor connected between R <sub>EL-osc</sub> and V <sub>DD</sub> of the device. The lamp frequency increases as R <sub>EL</sub> decreases. As the EL lamp frequency increases, the amount of current drawn from the battery will increase and the output voltage V <sub>CS</sub> will decrease. The color of the EL lamp is dependent upon its frequency.  A 3.3M $\Omega$ resistor would provide lamp frequency of 220 to 280Hz. Decreasing the R <sub>EL-osc</sub> by a factor of 2 will increase the lamp frequency by a factor of 2.
R <sub>SW-osc</sub>	The switching frequency of the converter is controlled via an external resistor, R <sub>SW</sub> between R <sub>SW-osc</sub> and V <sub>DD</sub> of the device. The switching frequency increases as R <sub>SW</sub> decreases. With a given inductor, as the switching frequency increases, the amount of current drawn from the battery will decrease and the output voltage, V <sub>CS</sub> , will also decrease.
C <sub>SW</sub> Capacitor	A 1nF capacitor is recommended on R <sub>SW-osc</sub> to GND when a 0.01 $\mu$ F C <sub>S</sub> capacitor is used. This capacitor is used to shunt any switching noise that may couple into the R <sub>SW-osc</sub> pin. The C <sub>SW</sub> capacitor may also be needed when driving large EL lamp due to an increase in switching noise.
Lx Inductor	The inductor L <sub>x</sub> is used to boost the low input voltage by inductive flyback. When the internal switch is on, the inductor is being charged. When the internal switch is off, the charge stored in the inductor will be transferred to the high voltage capacitor C <sub>S</sub> . The energy stored in the capacitor is connected to the internal H-bridge and therefore to the EL lamp. In general, smaller value inductors, which can handle more current, are more suitable to drive larger size lamps. As the inductor value decreases, the switching frequency of the inductor (controlled by R <sub>SW</sub> ) should be increased to avoid saturation.  220 $\mu$ H Murata inductors with 5.4 $\Omega$ series DC resistance is typically recommended. For inductors with the same inductance value but with lower series DC resistance, lower R <sub>SW</sub> value is needed to prevent high current draw and inductor saturation.
Lamp	As the EL lamp size increases, more current will be drawn from the battery to maintain high voltage across the EL lamp. The input power, (V <sub>IN</sub> x I <sub>IN</sub> ), will also increase. If the input power is greater than the power dissipation of the package (400mW), an external resistor in series with one side of the lamp is recommended to help reduce the package power dissipation.

### Figure 3: Split Supply Configuration

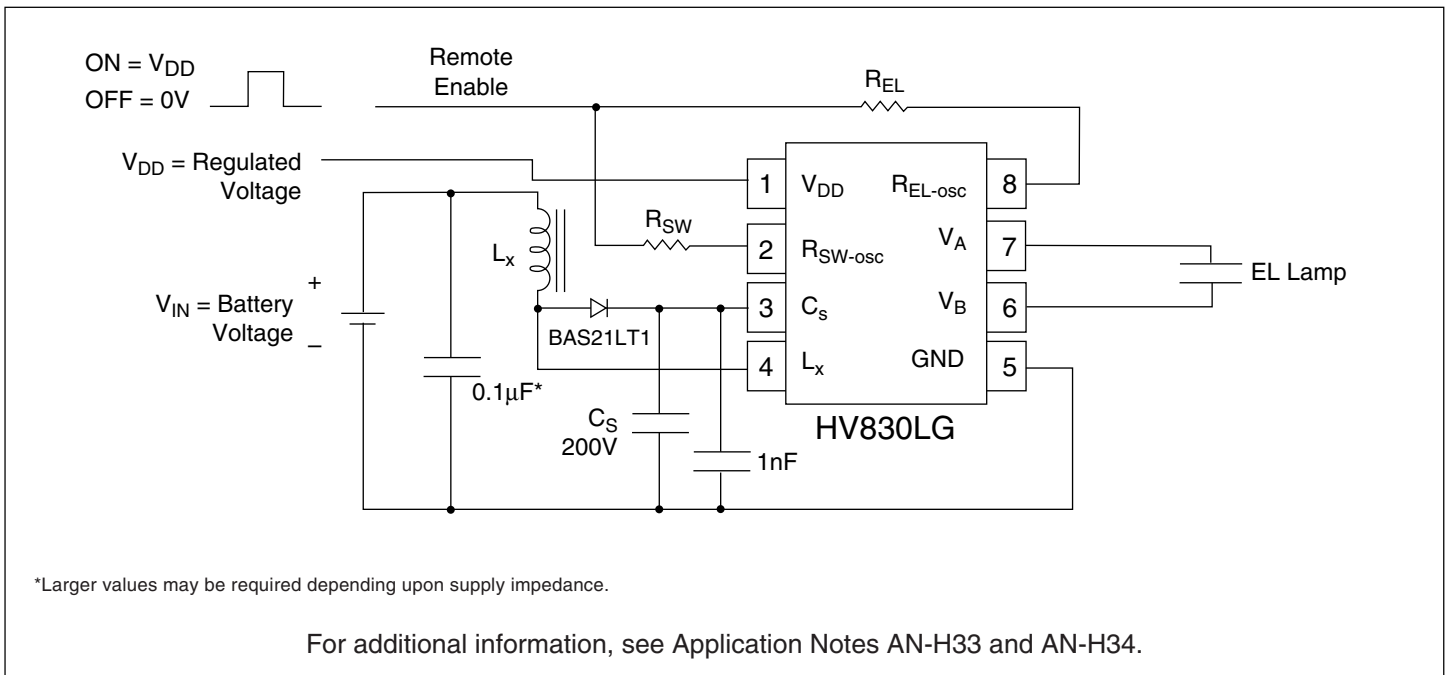



LittleDiode supplies new, hard to find or obsolete electronic components and semiconductors all over the world.

With over two million different components listed you are sure to find the part you need.

Feel free to visit us today at our online store:

**[LittleDiode.com](http://LittleDiode.com)**

Looking forward to providing you with the best possible service.