

# DATA SHEET

**74LVC16245A/  
74LVCH16245A**

16-bit bus transceiver with direction pin;  
5V tolerant (3-State)

Product specification  
Supersedes data of 1997 Aug 1  
IC24 Data Handbook

1997 Sep 25

# 16-bit bus transceiver with direction pin; 5V tolerant (3-State)

## 74LVC16245A/ 74LVCH16245A

### FEATURES

- 5 volt tolerant inputs/outputs for interfacing with 5V logic
- Wide supply voltage range of 1.2V to 3.6V
- Complies with JEDEC standard no. 8-1A
- CMOS low power consumption
- MULTIBYTE™ flow-through standard pin-out architecture
- Low inductance multiple power and ground pins for minimum noise and ground bounce
- Direct interface with TTL levels
- High impedance when  $V_{CC} = 0$
- All data inputs have bus hold (74LVCH16245A only)

### DESCRIPTION

The 74LVC(H)16245A is a high-performance, low-power, low-voltage, Si-gate CMOS device, superior to most advanced CMOS compatible TTL families. Inputs can be driven from either 3.3V or 5V devices. In 3-State operation, outputs can handle 5V. These features allow the use of these devices in a mixed 3.3V/5V environment.

The 74LVC(H)16245A is a 16-bit transceiver featuring non-inverting 3-State bus compatible outputs in both send and receive directions. The 74LVC(H)16245A features two output enable ( $n\overline{OE}$ ) inputs for easy cascading and two send/receive ( $n\overline{DIR}$ ) inputs for direction control.  $n\overline{OE}$  controls the outputs so that the buses are effectively isolated. This device can be used as two 8-bit transceivers or one 16-bit transceiver.

The 74LVCH16245A bus hold data inputs eliminates the need for extreme pull up resistors to hold unused inputs.

### PIN CONFIGURATION

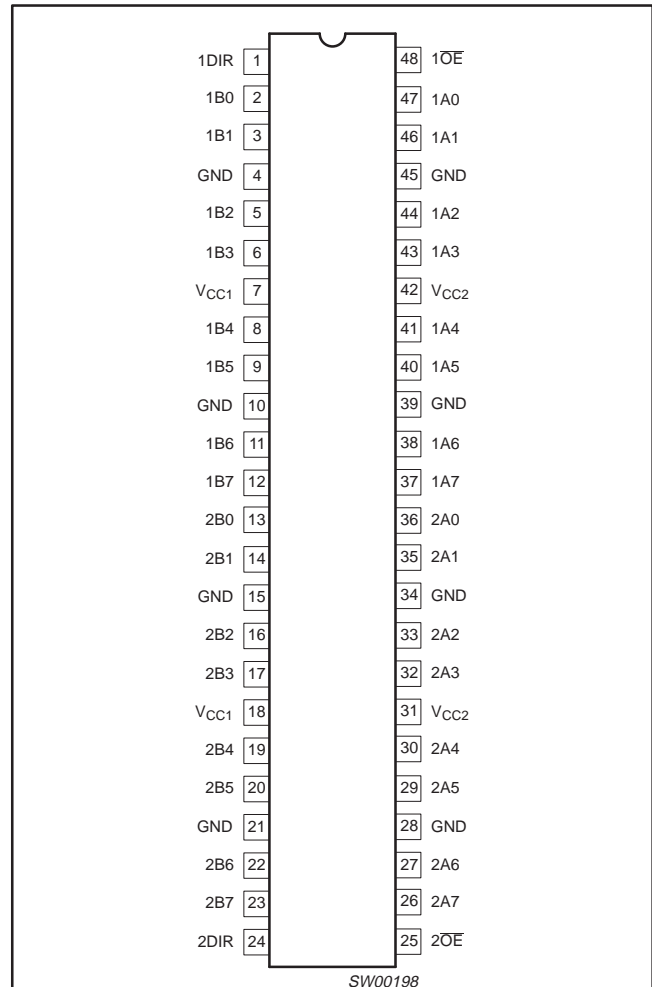

### ORDERING INFORMATION

| PACKAGES                     | TEMPERATURE RANGE | OUTSIDE NORTH AMERICA | NORTH AMERICA | DWG NUMBER |
|------------------------------|-------------------|-----------------------|---------------|------------|
| 48-Pin Plastic SSOP Type III | -40°C to +85°C    | 74LVC16245A DL        | VC16245A DL   | SOT370-1   |
| 48-Pin Plastic TSSOP Type II | -40°C to +85°C    | 74LVC16245A DGG       | VC16245A DGG  | SOT362-1   |
| 48-Pin Plastic SSOP Type III | -40°C to +85°C    | 74LVCH16245A DL       | VCH16245A DL  | SOT370-1   |
| 48-Pin Plastic TSSOP Type II | -40°C to +85°C    | 74LVCH16245A DGG      | VCH16245A DGG | SOT362-1   |

### QUICK REFERENCE DATA

GND = 0V;  $T_{amb} = 25^\circ\text{C}$ ;  $t_r = t_f \leq 2.5\text{ns}$

| SYMBOL            | PARAMETER                                  | CONDITIONS                                    | TYPICAL | UNIT |
|-------------------|--|---|---------|------|
| $t_{PHL}/t_{PLH}$ | Propagation delay<br>An to Bn;<br>Bn to An | $C_L = 50\text{pF}$<br>$V_{CC} = 3.3\text{V}$ | 3.0     | ns   |
| $C_I$             | Input capacitance                          |   | 5.0     | pF   |
| $C_{I/O}$         | Input/output capacitance                   |   | 10      | pF   |
| $C_{PD}$          | Power dissipation capacitance per buffer   | $V_I = \text{GND to } V_{CC}^1$               | 30      | pF   |

### NOTES:

- $C_{PD}$  is used to determine the dynamic power dissipation ( $P_D$  in  $\mu\text{W}$ ):  
 $P_D = C_{PD} \times V_{CC}^2 \times f_i + \sum (C_L \times V_{CC}^2 \times f_o)$  where:  
 $f_i$  = input frequency in MHz;  $C_L$  = output load capacity in pF;  
 $f_o$  = output frequency in MHz;  $V_{CC}$  = supply voltage in V;  
 $\sum (C_L \times V_{CC}^2 \times f_o)$  = sum of the outputs.

# 16-bit bus transceiver with direction pin; 5V tolerant (3-State)

## 74LVC16245A/ 74LVCH16245A

### PIN DESCRIPTION

| PIN NUMBER                     | SYMBOL          | NAME AND FUNCTION                |
|--------------------------------|-----------------|----------------------------------|
| 1                              | 1DIR            | Direction control                |
| 2, 3, 5, 6, 8, 9, 11, 12       | 1B0 to 1B7      | Data inputs/outputs              |
| 4, 10, 15, 21, 28, 34, 39, 45  | GND             | Ground (0V)                      |
| 7, 18, 31, 42                  | V <sub>CC</sub> | Positive supply voltage          |
| 13, 14, 16, 17, 19, 20, 22, 23 | 2B0 to 2B7      | Data inputs/outputs              |
| 24                             | 2DIR            | Direction control                |
| 25                             | 2OE             | Output enable input (active LOW) |
| 36, 35, 33, 32, 30, 29, 27, 26 | 2A0 to 2A7      | Data inputs/outputs              |
| 47, 46, 44, 43, 41, 40, 38, 37 | 1A0 to 1A7      | Data inputs/outputs              |
| 48                             | 1OE             | Output enable input (active LOW) |

### LOGIC SYMBOL

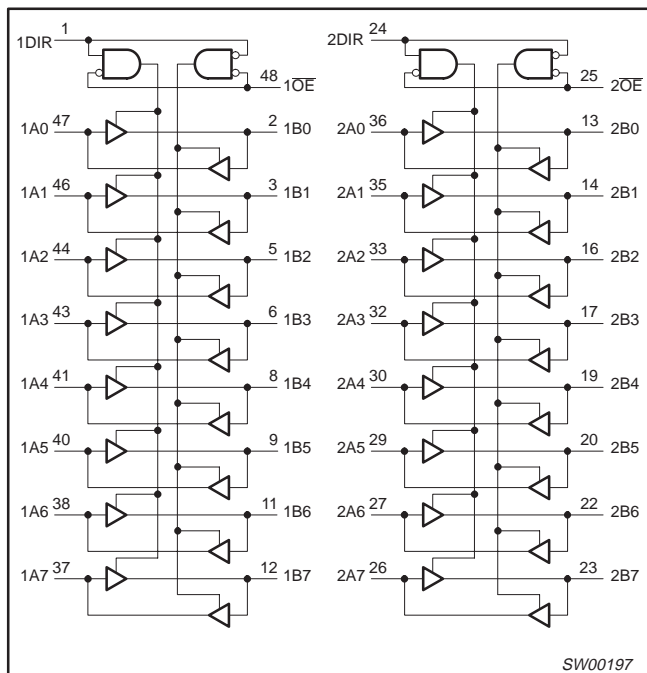

### LOGIC SYMBOL (IEEE/IEC)

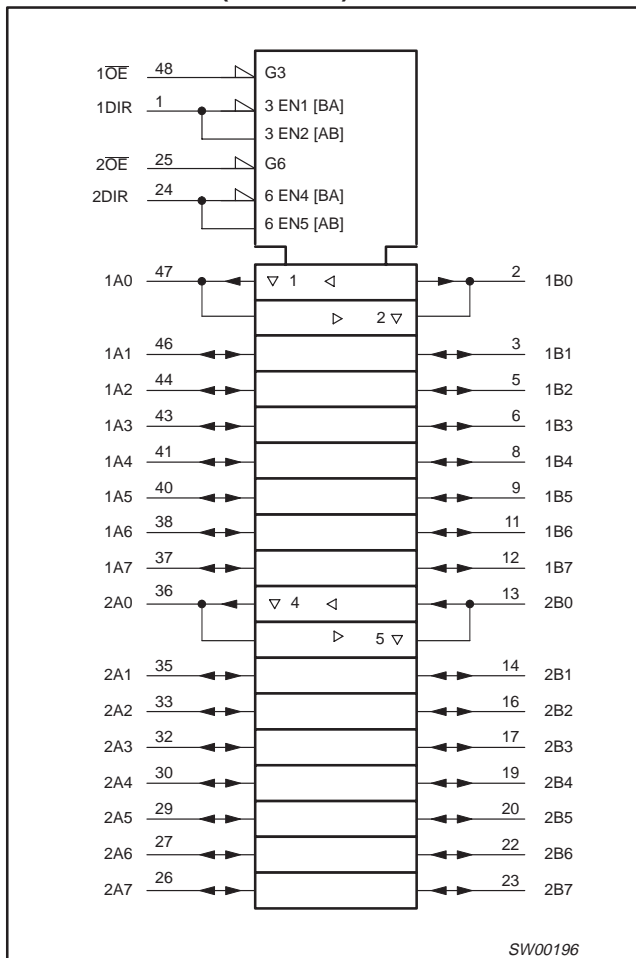

SW00196

### FUNCTION TABLE

| INPUTS |      | INPUTS/OUTPUT |        |
|--------|------|---------------|--------|
| nOE    | nDIR | nAn           | nBn    |
| L      | L    | A = B         | inputs |
| L      | H    | inputs        | B = A  |
| H      | X    | Z             | Z      |

H = HIGH voltage level  
L = LOW voltage level  
X = don't care  
Z = high impedance OFF-state

### BUS HOLD CIRCUIT

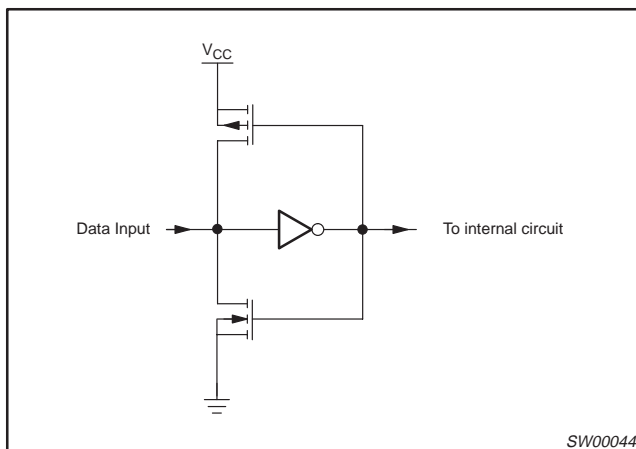

SW00044

# 16-bit bus transceiver with direction pin; 5V tolerant (3-State)

## 74LVC16245A/ 74LVCH16245A

### RECOMMENDED OPERATING CONDITIONS

| SYMBOL     | PARAMETER   | CONDITIONS   | LIMITS |          | UNIT |
|------------|---|--|--------|----------|------|
|            |   |  | MIN.   | MAX.     |      |
| $V_{CC}$   | DC supply voltage (for max. speed performance)    |  | 2.7    | 3.6      | V    |
| $V_{CC}$   | DC supply voltage (for low-voltage applications)  |  | 1.2    | 3.6      | V    |
| $V_I$      | DC Input voltage range                            |  | 0      | 5.5      | V    |
| $V_O$      | DC output voltage range; output HIGH or LOW state |  | 0      | $V_{CC}$ | V    |
| $V_O$      | DC output voltage range; output 3-State           |  | 0      | 5.5      | V    |
| $T_{amb}$  | Operating ambient temperature range in free air   |  | -40    | +85      | °C   |
| $t_r, t_f$ | Input rise and fall times                         | $V_{CC} = 1.2$ to $2.7V$<br>$V_{CC} = 2.7$ to $3.6V$ | 0<br>0 | 20<br>10 | ns/V |

### ABSOLUTE MAXIMUM RATINGS<sup>1</sup>

In accordance with the Absolute Maximum Rating System (IEC 134) Voltages are referenced to GND (ground = 0V)

| SYMBOL            | PARAMETER   | CONDITIONS   | LIMITS |                | UNIT |
|-------------------|---|--|--------|----------------|------|
|                   |   |  | MIN    | MAX            |      |
| $V_{CC}$          | DC supply voltage   |  | -0.5   | +6.5           | V    |
| $I_{IK}$          | DC input diode current  | $V_I < 0$  | -      | -50            | mA   |
| $V_I$             | DC input voltage  | Note 2   | -0.5   | +6.5           | V    |
| $I_{OK}$          | DC output diode current   | $V_O > V_{CC}$ or $V_O < 0$  | -      | ±50            | mA   |
| $V_O$             | DC output voltage; output HIGH or LOW state                               | Note 2   | -0.5   | $V_{CC} + 0.5$ | V    |
| $V_O$             | DC output voltage; output 3-State   | Note 2   | -0.5   | 6.5            | V    |
| $I_O$             | DC output source or sink current  | $V_O = 0$ to $V_{CC}$  | -      | ±50            | mA   |
| $I_{GND}, I_{CC}$ | DC $V_{CC}$ or GND current  |  | -      | ±100           | mA   |
| $T_{stg}$         | Storage temperature range   |  | -65    | +150           | °C   |
| $P_{tot}$         | Power dissipation per package<br>– SO package<br>– SSOP and TSSOP package | Above +70°C derate linearly 8mW/K<br>Above +60°C derate linearly 5.5mW/K |        | 500<br>500     | mW   |

#### NOTES:

- Stresses beyond those listed may cause permanent damage to the device. These are stress ratings only and functional operation of the device at these or any other conditions beyond those indicated under "recommended operating conditions" is not implied. Exposure to absolute-maximum-rated conditions for extended periods may affect device reliability.
- The input and output voltage ratings may be exceeded if the input and output clamp current ratings are observed.

# 16-bit bus transceiver with direction pin; 5V tolerant (3-State)

## 74LVC16245A/ 74LVCH16245A

### DC ELECTRICAL CHARACTERISTICS

Over recommended operating conditions. Voltages are referenced to GND (ground = 0V)

| SYMBOL            | PARAMETER   | TEST CONDITIONS  | LIMITS                |                  |      | UNIT |
|-------------------|---|--|-----------------------|------------------|------|------|
|                   |   |  | Temp = -40°C to +85°C |                  |      |      |
|                   |   |  | MIN                   | TYP <sup>1</sup> | MAX  |      |
| V <sub>IH</sub>   | HIGH level Input voltage                          | V <sub>CC</sub> = 1.2V   | V <sub>CC</sub>       |                  |      | V    |
|                   |   | V <sub>CC</sub> = 2.7 to 3.6V  | 2.0                   |                  |      |      |
| V <sub>IL</sub>   | LOW level Input voltage                           | V <sub>CC</sub> = 1.2V   |                       |                  | GND  | V    |
|                   |   | V <sub>CC</sub> = 2.7 to 3.6V  |                       |                  | 0.8  |      |
| V <sub>OH</sub>   | HIGH level output voltage                         | V <sub>CC</sub> = 2.7V; V <sub>I</sub> = V <sub>IH</sub> or V <sub>IL</sub> ; I <sub>O</sub> = -12mA       | V <sub>CC</sub> - 0.5 |                  |      | V    |
|                   |   | V <sub>CC</sub> = 3.0V; V <sub>I</sub> = V <sub>IH</sub> or V <sub>IL</sub> ; I <sub>O</sub> = -100μA      | V <sub>CC</sub> - 0.2 | V <sub>CC</sub>  |      |      |
|                   |   | V <sub>CC</sub> = 3.0V; V <sub>I</sub> = V <sub>IH</sub> or V <sub>IL</sub> ; I <sub>O</sub> = -18mA       | V <sub>CC</sub> - 0.6 |                  |      |      |
|                   |   | V <sub>CC</sub> = 3.0V; V <sub>I</sub> = V <sub>IH</sub> or V <sub>IL</sub> ; I <sub>O</sub> = -24mA       | V <sub>CC</sub> - 0.8 |                  |      |      |
| V <sub>OL</sub>   | LOW level output voltage                          | V <sub>CC</sub> = 2.7V; V <sub>I</sub> = V <sub>IH</sub> or V <sub>IL</sub> ; I <sub>O</sub> = 12mA        |                       |                  | 0.40 | V    |
|                   |   | V <sub>CC</sub> = 3.0V; V <sub>I</sub> = V <sub>IH</sub> or V <sub>IL</sub> ; I <sub>O</sub> = 100μA       |                       |                  | 0.20 |      |
|                   |   | V <sub>CC</sub> = 3.0V; V <sub>I</sub> = V <sub>IH</sub> or V <sub>IL</sub> ; I <sub>O</sub> = 24mA        |                       |                  | 0.55 |      |
| I <sub>I</sub>    | Input leakage current                             | V <sub>CC</sub> = 3.6V; V <sub>I</sub> = 5.5V or GND   |                       | ± 0.1            | ± 5  | μA   |
| I <sub>OZ</sub>   | 3-State output OFF-state current <sup>7</sup>     | V <sub>CC</sub> = 3.6V; V <sub>I</sub> = V <sub>IH</sub> or V <sub>IL</sub> ; V <sub>O</sub> = 5.5V or GND |                       | 0.1              | ± 5  | μA   |
| I <sub>off</sub>  | Power off leakage supply                          | V <sub>CC</sub> = 0.0V; V <sub>I</sub> or V <sub>O</sub> = 5.5V  |                       | 0.1              | ± 10 | μA   |
| I <sub>CC</sub>   | Quiescent supply current                          | V <sub>CC</sub> = 3.6V; V <sub>I</sub> = V <sub>CC</sub> or GND; I <sub>O</sub> = 0                        |                       | 0.1              | 20   | μA   |
| ΔI <sub>CC</sub>  | Additional quiescent supply current per input pin | V <sub>CC</sub> = 2.7V to 3.6V; V <sub>I</sub> = V <sub>CC</sub> - 0.6V; I <sub>O</sub> = 0                |                       | 5                | 500  | μA   |
| I <sub>BHL</sub>  | Bus hold LOW sustaining current                   | V <sub>CC</sub> = 3.0V; V <sub>I</sub> = 0.8V <sup>2, 3, 4</sup>   | 75                    |                  |      | μA   |
| I <sub>BHH</sub>  | Bus hold HIGH sustaining current                  | V <sub>CC</sub> = 3.0V; V <sub>I</sub> = 2.0V <sup>2, 3, 4</sup>   | -75                   |                  |      | μA   |
| I <sub>BHLO</sub> | Bus hold LOW overdrive current                    | V <sub>CC</sub> = 3.6V <sup>2, 3, 5</sup>  | 500                   |                  |      | μA   |
| I <sub>BHHO</sub> | Bus hold HIGH overdrive current                   | V <sub>CC</sub> = 3.6V <sup>2, 3, 5</sup>  | -500                  |                  |      | μA   |

#### NOTES:

- All typical values are at V<sub>CC</sub> = 3.3V and T<sub>amb</sub> = 25°C.
- Valid for data inputs of bus hold parts (LVCH16-A) only.
- For data inputs only, control inputs do not have a bus hold circuit.
- The specified sustaining current at the data input holds the input below the specified V<sub>I</sub> level.
- The specified overdrive current at the data input forces the data input to the opposite logic input state.
- For bus hold parts, the bus hold circuit is switched off when V<sub>I</sub> exceeds V<sub>CC</sub> allowing 5.5V on the input terminal.
- For I/O ports the parameter I<sub>OZ</sub> includes the input leakage current.

### AC CHARACTERISTICS

GND = 0V; t<sub>R</sub> = t<sub>F</sub> = 2.5ns; C<sub>L</sub> = 50pF; R<sub>L</sub> = 500Ω; T<sub>amb</sub> = -40°C to +85°C.

| SYMBOL                               | PARAMETER  | WAVEFORM | LIMITS                        |                  |     |                        |     |                        | UNIT |
|--------------------------------------|--|----------|-------------------------------|------------------|-----|------------------------|-----|------------------------|------|
|                                      |  |          | V <sub>CC</sub> = 3.3V ± 0.3V |                  |     | V <sub>CC</sub> = 2.7V |     | V <sub>CC</sub> = 1.2V |      |
|                                      |  |          | MIN                           | TYP <sup>1</sup> | MAX | MIN                    | MAX | TYP                    |      |
| t <sub>PHL</sub><br>t <sub>PLH</sub> | Propagation delay<br>nAn to nBn;<br>nBn to nAn           | 1        | 1.5                           | 3                | 4.5 | 1.5                    | 5.5 | 13                     | ns   |
| t <sub>PZH</sub><br>t <sub>PZL</sub> | 3-State output enable time<br>nOE to nAn;<br>nOE to nBn  | 2, 3     | 1.5                           | 4                | 6.1 | 1.5                    | 7.1 | 15                     | ns   |
| t <sub>PHZ</sub><br>t <sub>PLZ</sub> | 3-State output disable time<br>nOE to nAn;<br>nOE to nBn | 2, 3     | 1.5                           | 4                | 5.6 | 1.5                    | 6.6 | 11                     | ns   |

#### NOTE:

- All typical values are at V<sub>CC</sub> = 3.3V and T<sub>amb</sub> = 25°C.

# 16-bit bus transceiver with direction pin; 5V tolerant (3-State)

## 74LVC16245A/ 74LVCH16245A

### AC WAVEFORMS

$V_M = 1.5V$  at  $V_{CC} \geq 2.7V$ ;  $V_M = 0.5 V_{CC}$  at  $V_{CC} < 2.7V$ .  
 $V_{OL}$  and  $V_{OH}$  are the typical output voltage drop that occur with the output load.  
 $V_X = V_{OL} + 0.3V$  at  $V_{CC} \geq 2.7V$ ;  $V_X = V_{OL} + 0.1 V_{CC}$  at  $V_{CC} < 2.7V$   
 $V_Y = V_{OH} - 0.3V$  at  $V_{CC} \geq 2.7V$ ;  $V_Y = V_{OH} - 0.1 V_{CC}$  at  $V_{CC} < 2.7V$

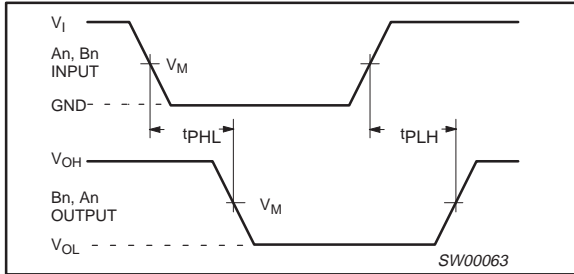

**Waveform 1. Input (nAn, nBn) to output (nBn, nAn) propagation delay times**

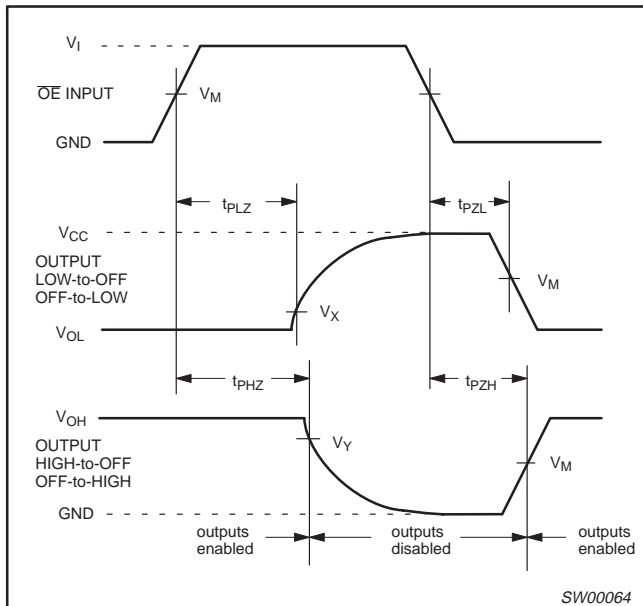

**Waveform 2. 3-State enable and disable times**

### TEST CIRCUIT

**Test Circuit for 3-State Outputs**

**SWITCH POSITION**

| TEST              | SWITCH       |
|-------------------|--------------|
| $t_{PLH}/t_{PHL}$ | Open         |
| $t_{PLZ}/t_{PZL}$ | $2 * V_{CC}$ |
| $t_{PHZ}/t_{PZH}$ | GND          |

| $V_{CC}$     | $V_{IN}$ |
|--------------|----------|
| $< 2.7V$     | $V_{CC}$ |
| $2.7 - 3.6V$ | $2.7V$   |

**DEFINITIONS**  
 $R_L$  = Load resistor  
 $C_L$  = Load capacitance includes jig and probe capacitance  
 $R_T$  = Termination resistance should be equal to  $Z_{OUT}$  of pulse generators.

SW00047

**Waveform 3. Load circuitry for switching times**

16-bit bus transceiver with direction pin; 5V tolerant  
(3-State)

74LVC16245A/  
74LVCH16245A

SSOP48: plastic shrink small outline package; 48 leads; body width 7.5 mm

SOT370-1

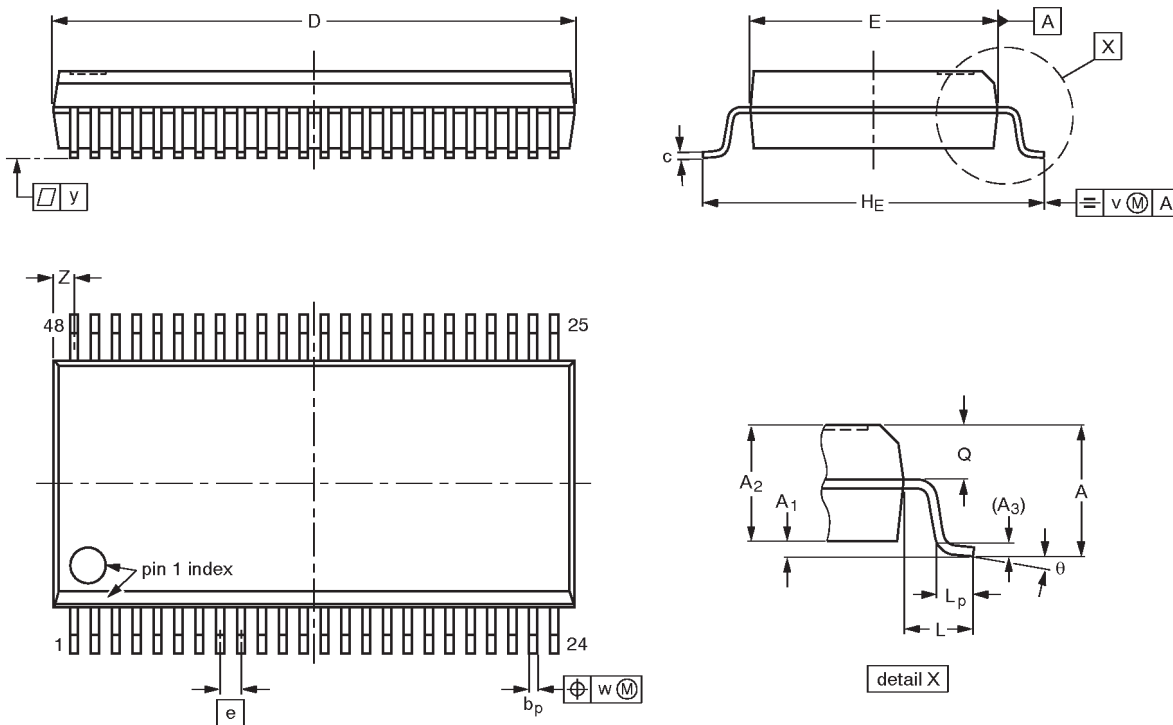

DIMENSIONS (mm are the original dimensions)

| UNIT | A max. | A <sub>1</sub> | A <sub>2</sub> | A <sub>3</sub> | b <sub>p</sub> | c            | D <sup>(1)</sup> | E <sup>(1)</sup> | e     | H <sub>E</sub> | L   | L <sub>p</sub> | Q          | v    | w    | y   | Z <sup>(1)</sup> | θ        |
|------|--------|----------------|----------------|----------------|----------------|--------------|------------------|------------------|-------|----------------|-----|----------------|------------|------|------|-----|------------------|----------|
| mm   | 2.8    | 0.4<br>0.2     | 2.35<br>2.20   | 0.25           | 0.3<br>0.2     | 0.22<br>0.13 | 16.00<br>15.75   | 7.6<br>7.4       | 0.635 | 10.4<br>10.1   | 1.4 | 1.0<br>0.6     | 1.2<br>1.0 | 0.25 | 0.18 | 0.1 | 0.85<br>0.40     | 8°<br>0° |

Note

1. Plastic or metal protrusions of 0.25 mm maximum per side are not included.

| OUTLINE VERSION | REFERENCES |          |      |  | EUROPEAN PROJECTION | ISSUE DATE            |
|-----------------|------------|----------|------|--|---------------------|-----------------------|
|                 | IEC        | JEDEC    | EIAJ |  |                     |                       |
| SOT370-1        |            | MO-118AA |      |  |                     | 93-11-02-<br>95-02-04 |

# 16-bit bus transceiver with direction pin; 5V tolerant (3-State)

## 74LVC16245A/ 74LVCH16245A

**TSSOP48:** plastic thin shrink small outline package; 48 leads; body width 6.1mm

**SOT362-1**

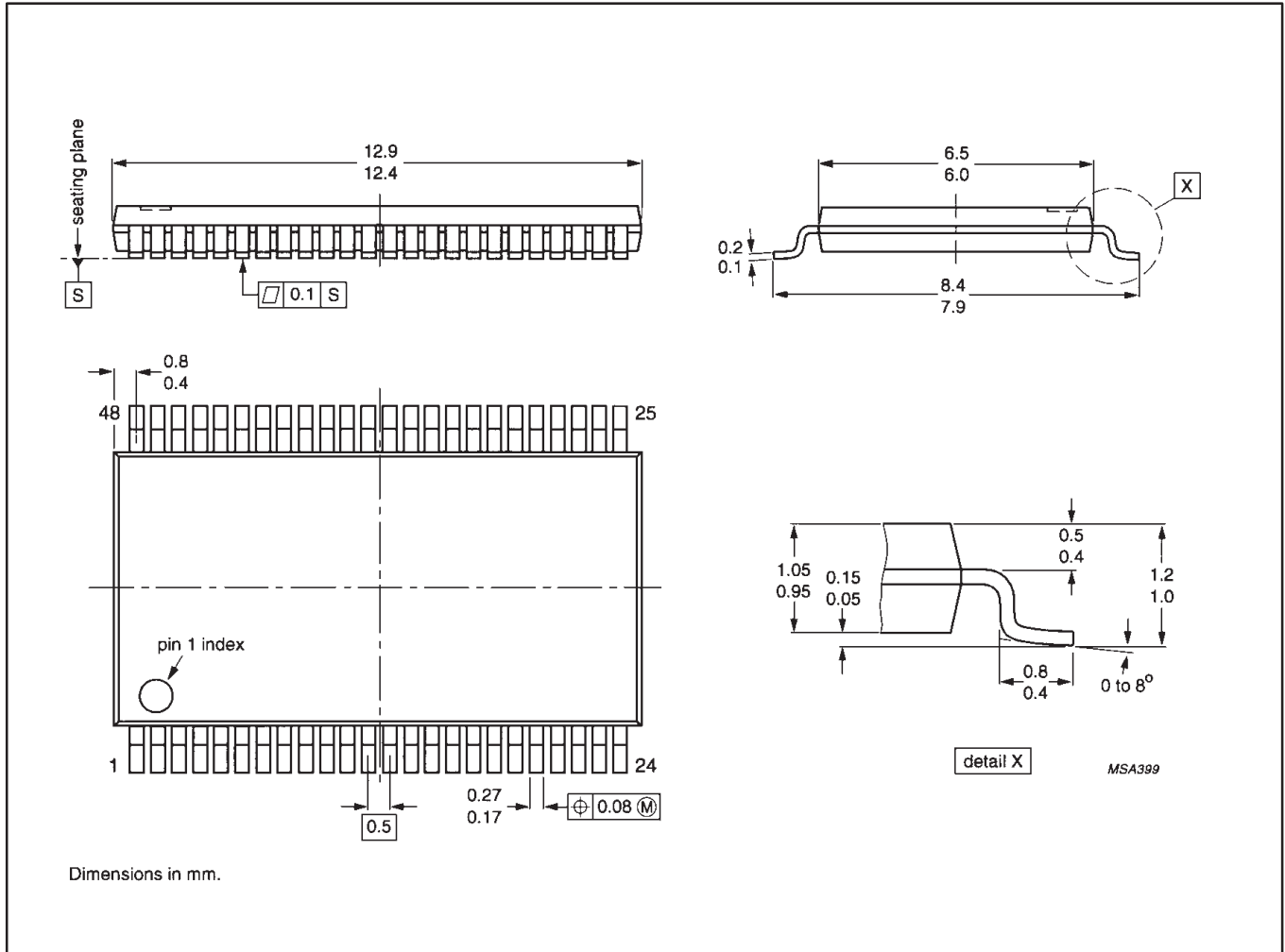

---

16-bit bus transceiver with direction pin; 5V tolerant  
(3-State)

---

74LVC16245A/  
74LVCH16245A

---

**NOTES**

16-bit bus transceiver with direction pin; 5V tolerant  
(3-State)

74LVC16245A/  
74LVCH16245A

## DEFINITIONS

| Data Sheet Identification        | Product Status                | Definition   |
|----------------------------------|-------------------------------|--|
| <i>Objective Specification</i>   | <b>Formative or in Design</b> | This data sheet contains the design target or goal specifications for product development. Specifications may change in any manner without notice.   |
| <i>Preliminary Specification</i> | <b>Preproduction Product</b>  | This data sheet contains preliminary data, and supplementary data will be published at a later date. Philips Semiconductors reserves the right to make changes at any time without notice in order to improve design and supply the best possible product. |
| <i>Product Specification</i>     | <b>Full Production</b>        | This data sheet contains Final Specifications. Philips Semiconductors reserves the right to make changes at any time without notice, in order to improve design and supply the best possible product.  |

Philips Semiconductors and Philips Electronics North America Corporation reserve the right to make changes, without notice, in the products, including circuits, standard cells, and/or software, described or contained herein in order to improve design and/or performance. Philips Semiconductors assumes no responsibility or liability for the use of any of these products, conveys no license or title under any patent, copyright, or mask work right to these products, and makes no representations or warranties that these products are free from patent, copyright, or mask work right infringement, unless otherwise specified. Applications that are described herein for any of these products are for illustrative purposes only. Philips Semiconductors makes no representation or warranty that such applications will be suitable for the specified use without further testing or modification.

### LIFE SUPPORT APPLICATIONS

Philips Semiconductors and Philips Electronics North America Corporation Products are not designed for use in life support appliances, devices, or systems where malfunction of a Philips Semiconductors and Philips Electronics North America Corporation Product can reasonably be expected to result in a personal injury. Philips Semiconductors and Philips Electronics North America Corporation customers using or selling Philips Semiconductors and Philips Electronics North America Corporation Products for use in such applications do so at their own risk and agree to fully indemnify Philips Semiconductors and Philips Electronics North America Corporation for any damages resulting from such improper use or sale.

**Philips Semiconductors**  
811 East Arques Avenue  
P.O. Box 3409  
Sunnyvale, California 94088-3409  
Telephone 800-234-7381

© Copyright Philips Electronics North America Corporation 1997  
All rights reserved. Printed in U.S.A.

print code

Date of release: 05-96

Document order number:

9397-750-04531

*Let's make things better.*



LittleDiode supplies new, hard to find or obsolete electronic components and semiconductors all over the world.

With over two million different components listed you are sure to find the part you need.

Feel free to visit us today at our online store:

[LittleDiode.com](http://LittleDiode.com)

Looking forward to providing you with the best possible service.