

AS2702 (SAP4.1)

AS-Interface Slave IC

Data Sheet

Rev. C, January 2001

Key Features

- Interface Device to connect Actuators and Sensors to an AS-Interface Bus
- Conforms to AS-Interface Spec. V2.11
- DC Power Extraction from the AS-Interface Bus
- Serial bidir. Data Communication with the Bus
- Data Communication Watchdog
- 4-Bit bidir. Data Port plus Strobe to poll the Sensors and control the Actuators connected
- 4-Bit Parameter Port plus Strobe to provide Settings to the Sensors and Actuators
- 24V Power Supply for the Sensors and Actuators
- Periphery Fault Input to signal Hardware Failure of the Sensors and Actuators
- Integrated 16 x 8 Bit EEPROM to store (5 + 1)-Bit Slave Address and Settings
- 2 LED Outputs to optically flag Slave Unit Operation Status
- Operating Temperature T_a : - 25 °C ... + 85 °C
- Operating Supply Voltage / Bus DC Voltage: typ. 30 V
- Operating Current (Osc. on, Outputs idle): ≤ 6 mA
- Supply for Sensors / Actuators: typ. 24 V, ≤ 50 mA
- Package: SOIC 20 for full Functionality;
SOIC 16 for Applications not requiring the Parameter Port

General Description

AS2702 (SAP4.1) is a new generation AS-interface slave device conforming to AS-interface-specification V2.11, which supports AS-interface bus systems with up to 62 slave modules.

Each slave module is equipped with an AS2702 device, which interfaces the module to the unshielded 2-wire AS-interface bus for serial bidirectional data communication and power extraction.

Data communication over the AS-interface bus takes place in master slave fashion, which foresees that all slave devices AS2702 connected to the bus are sequentially and cyclicly addressed by a single, central master unit. Data on the AS-interface bus are Manchester encoded and can be found as sin2-pulses with a V_{pp} of between 3V and 8V on top of the bus' dc voltage of nominally 30V.

AS2702 regulates the nominal dc bus voltage of 30V internally down to 5V to supply it's internal circuitry including a 16 x 8 bits EEPROM, as well as down to a nominal supply level 24V with a max. loading of 50 mA for the actuators and sensors connected to it at the field side.

Each slave device AS2702 may interface to up to 4 sensors or 3 actuators. An AS-interface bus system based on AS2702 may hence link as many as 248 sensors or 186 actuators to a single master unit.

Slave device AS2702 (SAP4.1) is system compatible with predecessor device AS2701A (ISA3+): slave modules equipped with AS2702 (SAP4.1) will run in existing AS-interface bus systems based on AS2701A (ISA3+).

The AS-interface concept is well established as a standardized digital bus system for industrial automation.

Block Diagram

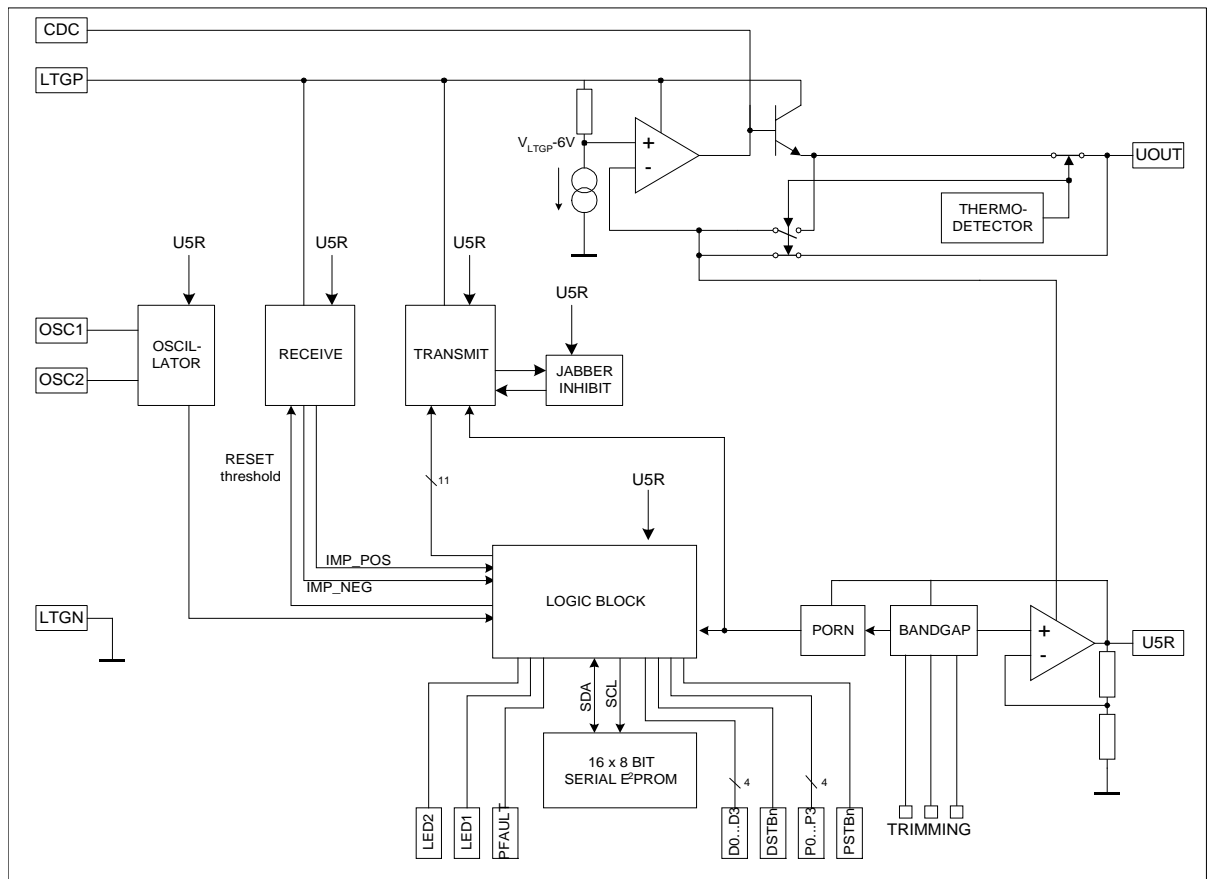

Pin Assignment and Description

SOIC 20 Pin Nr.:	SOIC 16 Pin Nr.:	Name	Type	Note	Description
1	--	P1	I/O, digital, pull-up	1, 2	Bidir. parameter port bit 1
2	--	P0	I/O, digital, pull-up	1, 2	Bidir. parameter port bit 0
3	1	D1	I/O, digital		Bidir. data port bit 1
4	2	D0	I/O, digital		Bidir. data port bit 0
5	3	DSTBn	I/O, digital, pull-up	1	Data port strobe output; reset-input
6	4	LED1	I/O, digital, pull-up	1	LED output 1 (IC test input)
7	5	OSC2	O, analog		Output to quartz crystal
8	6	OSC1	I, analog		Input from quartz crystal
9	7	U5R	O, power		Nom. 5V power supply output
10	8	LTGN	I, power		Neg. supply pin, connected

					to neg. AS-interface bus line; ground reference.
11	9	LTGP	I, power		Pos. supply pin, connected to pos. AS-interface bus line
12	10	CDC	I/O, analog		Pin for ext. buffer capacitor
13	11	UOUT	O, power		Nom. 24V power supply output
14	12	PFAULT	I, digital, pull-up	1	Low-active input to flag failure of the sensors / actuators circuitry con- nected
15	13	LED2	I/O, digital, pull-up	1	LED output 2 (IC test input)
16	14	PSTBn	I/O, digital, pull-up	1	Parameter port strobe output (IC test input)
17	15	D3	I/O, digital		Bidir. data port bit 3
18	16	D2	I/O, digital		Bidir. data port bit 2
19	--	P3	I/O, digital, pull-up	1, 2	Bidir. parameter port bit 3
20	--	P2	I/O, digital, pull-up	1, 2	Bidir. parameter port bit 2

Notes:

- 1 The pull-up structure is a passive high-side current source with a nom. 10 μ A current
- 2 The passive pull-up current source as per note 1 on these parameter port pins is off, if the slave device is programmed with I/O-configuration code 7 and a master data call is present

Functional, electrical and timing characteristics

All voltages are referenced to ground pin LTGN. Timing is valid for a quartz crystal frequency of 5.333 MHz.

a) Absolute maximum ratings

Symbol	Parameter	Min.	Max.	Unit	Note
VLTGP	Voltage at the positive supply pin	- 0.3	40	V	1
VCDC	Voltage at pin for ext. buffer capacitor	- 0.3	VLTGP + 0.3V	V	
VU5R	Voltage at pins U5R, OSC1, OSC2	- 0.3	7	V	
IIN	Input current at any pin, except for LTGP, CDC	- 50	50	mA	2
ESD1	Electrostatic discharge voltage	1500		V	3
ESD2	Electrostatic discharge voltage	200		V	4
θ STG	Storage temperature	- 55	125	V	
θ LEAD	Solder temperature		260	$^{\circ}$ C	5
PTOT	Max. power dissipation		1	W	6
RTHJA	Thermal resistance SOIC 16	61.2	74.8	$^{\circ}$ K / W	7
RTHJA	Thermal resistance SOIC 20	58.5	71.5	$^{\circ}$ K / W	7

Notes:

- 1 50 V during $t > 50 \mu\text{s}$; repetition rate $< 0.5 \text{ Hz}$
- 2 Latch-up immunity test. Pls. observe max. power dissipation allowed.
- 3 Human body model: $R = 1.5 \text{ k}\Omega$; $C = 100 \text{ pF}$
- 4 Machine model; applies only for LTGP-LTGN
- 5 $260 \text{ }^\circ\text{C}$ during 10 s (reflow and wave soldering); $360 \text{ }^\circ\text{C}$ during 3 s for manual soldering. Twofold reflow soldering is acceptable.
- 6 Free convection, see fig. 1
- 7 No forced cooling. PCB-surface: 21 cm^2 ; still air volume around the device: 10 cm^3

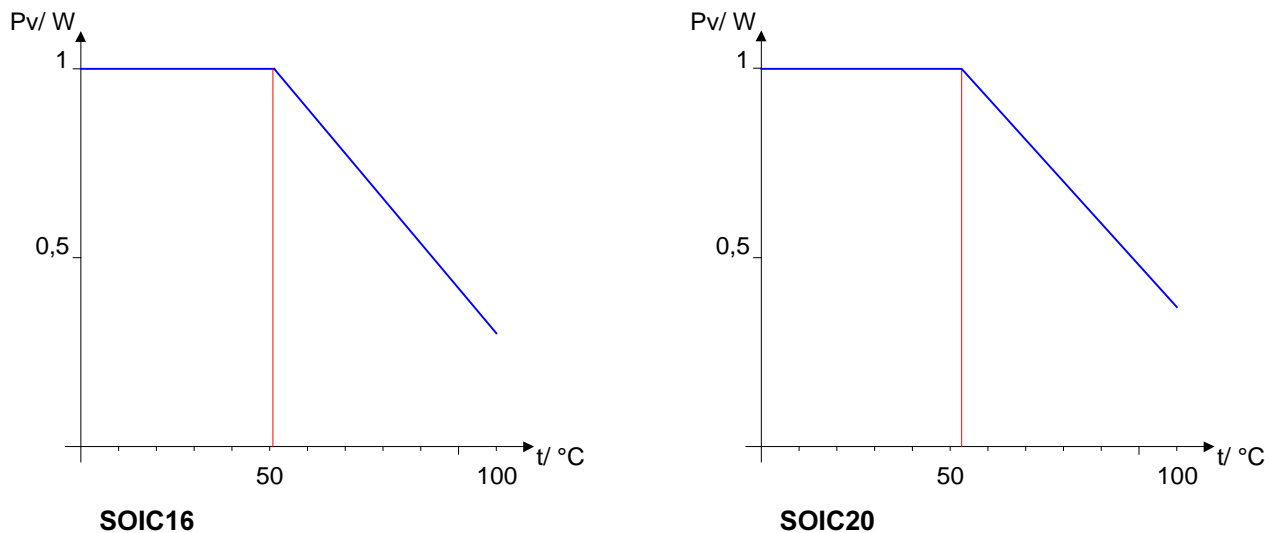

Fig. 1: Max. acceptable power dissipation relative to ambient temperature

b) Recommended Operating Conditions

Symbol	Parameter	min.	nom.	max.	Unit	Note
VLTGP	Positive supply voltage / dc portion	17.5		34	V	1
ILTG	Supply current consumption			6	mA	2
OA	Ambient temperature	- 25	25	85	°C	3
FC	Quartz frequency		5.3333 33		MHz	4
	Sensitivity against moisture					5

Notes:

- 1 False-poling protection diode to be inserted between pos. AS-interface bus line and LTGP-pin. LTGP-pin to be protected furthermore with a voltage clamp between LTGP and LTGN.
- 2 Oscillator on; data transmission stage off; no loads connected
- 3 Power dissipation restrictions as per fig. 1 to be observed
- 4 ASI Quarz
- 5 Level 5 acc. to JEDEC-standard JESD22-A112, Table 1

c) Supply pin LTGP

Positive supply pin connected to positive AS-interface bus line and clamped relative to neg. supply pin / ground LTGN as described under Recommended Operating Conditions. VLTGP and ILTG specified under Recommended Operating Conditions as well.

Symbol	Parameter	min.	max.	Unit	Note
VSIG	VPP of sin2-data-pulses on top of dc supply voltage	3	8	V	
Z	Input impedance between 50 kHz and 300 kHz		40	pF	CCDC = 100 nF 1
		18		kOhm	1
		50		mH	1

Note:

- 1 Input equivalent circuit is parallel arrangement of C, R and L

d) Buffer pin CDC

An external buffer capacitor with a recommended value of 100 nF should be connected to this pin to ensure a sufficiently high input impedance Z at power supply pin LTGP. Voltage at this pin can be as high as VLTGP.

e) Nom. 24V power supply output UOUT

The supply output voltage at UOUT is directly derived from VLTGP and regulated to a level with an offset of about - 6V relative to VLTGP.

UOUT provides bias to the sensors and actuators circuitry connected to the slave device as well as to the LEDs connected to outputs LED1 and LED2.

UOUT is equipped with a thermal overload protection, which foresees that VUOUT is switched off as soon as the slave device's substrate temperature TJ passes a threshold value in the range of (155 +- 20)°C.

After TJ has come down and has passed a temperature threshold about (15 +- 5)°C lower than (155 +- 20)°C and after a consecutive minimum delay of 1 s has elapsed, VUOUT is switched on again.

Symbol	Parameter	min.	max.	Unit	Note
VUOUT	Power supply output voltage	VLTGP - 6.3V	VLTGP - 5.3V	V	
IUOUT	Load current		50	mA	1
VCOMOFF	UOUT voltage level below which data transmission is inhibited	9.5	10.5	V	
CUOUT	Buffer capacitor	10		µF	2

Notes:

- 1 In case IUOUT > 40 mA and presence of sin2-data pulses on LTGP

- with VSIG > 3V, VUOUT may drop as much as 1V below it's level in unloaded condition
- 2 Electrolythic and rf filter capacitor in parallel

f) Nom. 5V power supply output U5R

The voltage at U5R is derived from the voltage present at UOUT, as long as UOUT is not switched off due to overload. In the latter case U5R is derived from an alternative voltage out of the UOUT voltage regulator, which is more or less similar to VUOUT in non switched off condition of UOUT. As a result VU5R is not affected by overload condition at UOUT and will remain.

Symbol	Parameter	min.	max.	Unit
VU5R	Power supply output voltage	4.85	5.15	V
IU5R	Load current		1	mA
CU5R	Buffer capacitor	100		nF

g) Oscillatorpins OSC1 and OSC2

The only component to be connected to these pins is a quartz crystal with a resonance frequency of 5.333333 MHz (AS-Interface quartz crystal).

Symbol	Parameter	min.	max.	Unit
CX2	Stray capacitance		10	pF

h) Data port pins D3, ..., D0 and data strobe pin DSTBn

Basically data port D3, ..., D0 is designed for bidirectional data transfer out of and into the slave device. Each data port pin is equipped with both a low-side open-drain output stage as well as an input stage to this purpose.

Depending on the so called IO-configuration code, written into and stored in the slave device, each data port pin is individually set to behave as

- output, or
- output / input, or
- input.

The timing of the data transfer is presented in fig. 2.

Strobe signal DSTBn flags and governs the data transfer as follows:

ha) data port pin is set 'output':

output data become valid upon the HL-edge of the strobe and will remain so until the next HL-edge, hence during the entire strobe cycle;

hb) data port pin is set 'output / input':

output data become valid upon the HL-edge of the strobe and will remain so until it's LH-edge; input data to be valid within a specific time window relative to the HL-edge, after completion of the strobe's L-phase;

hc) data port pin is set 'input':

input data to be valid within a specific time window relative to the HL-edge of the strobe, after completion of the strobe's L-phase.

If necessary, output data as per ha) and hb) can be easily latched with the LH-edge of strobe DSTBn as they will remain valid for about 0.4 μs beyond as a minimum. Care must be taken however, that signal delay added by external circuitry is lower for the strobe than for the data.

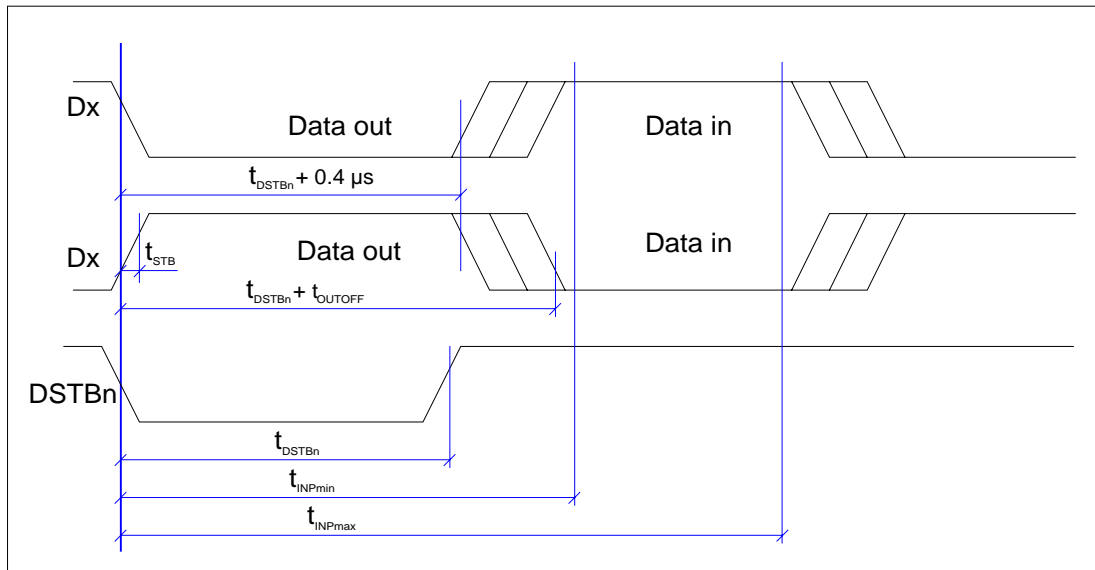

Fig. 2: Timing of data transfer at data port D3, ..., D0 relative to strobe DSTBn

The following table specifies the timing parameters relating to fig. 2:

Symbol	Parameter	min.	max.	Unit	Note
t_{STB}	Delay DSTBn HL-edge to Dx output data valid		1.5	μs	
t_{DSTBn}	DSTBn strobe width	6	6.8	μs	1
t_{OUTOFF}	Delay DSTBn LH-edge to Dx output off	0.2	1	μs	2
t_{INP}	Input data valid time window	10.5	12.5	μs	3

Notes:

- 1 Pulse width depends substantially on value of external pull-up resistor
- 2 Applies only to data port pins set to 'output / input' operation
- 3 Timing reference is DSTBn HL-edge.
Applies only to data port pins set to either 'output / input' or 'input' operation

The dc-parameters of the data port pins D3, ..., D0 are specified as follows:

Symbol	Parameter	min.	max.	Unit	Note
IOUTLO	Sink current @ output L	10		mA	VOUT = 1V
IOUTH1	Leakage current @ output off	- 1	1	µA	1
VSCHLT	Input threshold voltage	2.5	3.5	V	2
VIN	Acceptable input voltage @ output off	- 0.3	40	V	

Notes:

- 1 Output stage is low-side open-drain; ext. pull-up resistor required as no pull-up structure on chip
- 2 No hysteresis implemented

To govern the data transfer at data port D3, ...,D0 strobe pin DSTBn is equipped with a low-side open-drain output switch plus a passive high-side current source with a nom. 10 µA pull-up current capability.

However a second function is assigned to the DSTBn pin which requires it to be input as well: if a low-pulse is imposed on DSTBn by external means with a pulse width of at least 50 to 100 ms, the slave device will be put in RESET condition, as described in section "Reset".

The dc-and timing parameters of strobe pin DSTBn are specified as follows:

Symbol	Parameter	min.	max.	Unit	Note
IOUTLO	Sink current @ output L	10		mA	VOUT = 1V
IOUTH1	Leakge current @ output off	- 10	10	µA	VOUT = 5V
IINLO	Input current @ VIN = 1V	- 5	- 20	µA	1
VSCHLT	Input threshold voltage	1.5	3.5	V	2
VIN	Acceptable input voltage @ output off	- 0.3	40	V	
tNORESET	DSTBn L-phase width, not triggering RESET		50	ms	
tRESET	DSTBn L-phase width, triggering RESET	100		ms	
CPINEXT	Stray capacitance		20	pF	

Notes:

- 1 DSTBn is equipped with an on-chip pull-up current source, which ensures a sufficiently fast LH-edge upon output switch-off in open-pin condition, to prevent erroneous RESET triggering.
If DSTBn has an external load connected to it, an additional external pull-up resistor may be needed to prevent erroneous RESET triggering upon output switch-off
- 2 No hysteresis implemented

i) Parameter port pins P3, ..., P0 and parameter strobe pin PSTBn

(Note that parameter port pins P3, ..., P0 are only available on AS2702 package option SOIC 20, not on the SOIC 16 option.)

The transfer of data at P3, ..., P0 and the supporting strobe action at pin PSTBn takes place similarly as at D3, ..., D0 resp. DSTBn.

Each parameter port pin P3, ..., P0 is equipped with both a low-side open-drain output switch plus a passive, but switchable high-side current source with a nom. 10 μ A pull-up current capability, and with an input stage.

Though equipped for bidirectional data transfer as D3, ..., D0, the parameter port is less flexible than the data port.

Basically the parameter port is set to behave portwise as

- output, or
- input

depending on the IO-configuration code, written into and stored in the slave device.

The timing of the data transfer is presented in fig. 3.

Strobe signal PSTBn flags and governs the data transfer as follows:

ia) parameter port is set 'output':

output data become valid upon the HL-edge of the strobe and will remain so until the next HL-edge, hence during the entire strobe cycle;

ib) parameter port is set 'input':

input data to be valid within a specific time window relative to the HL-edge of the strobe, after completion of the strobe's L-phase.

Output data as per ia) could be easily latched with the LH-edge of strobe PSTBn, if at all necessary.

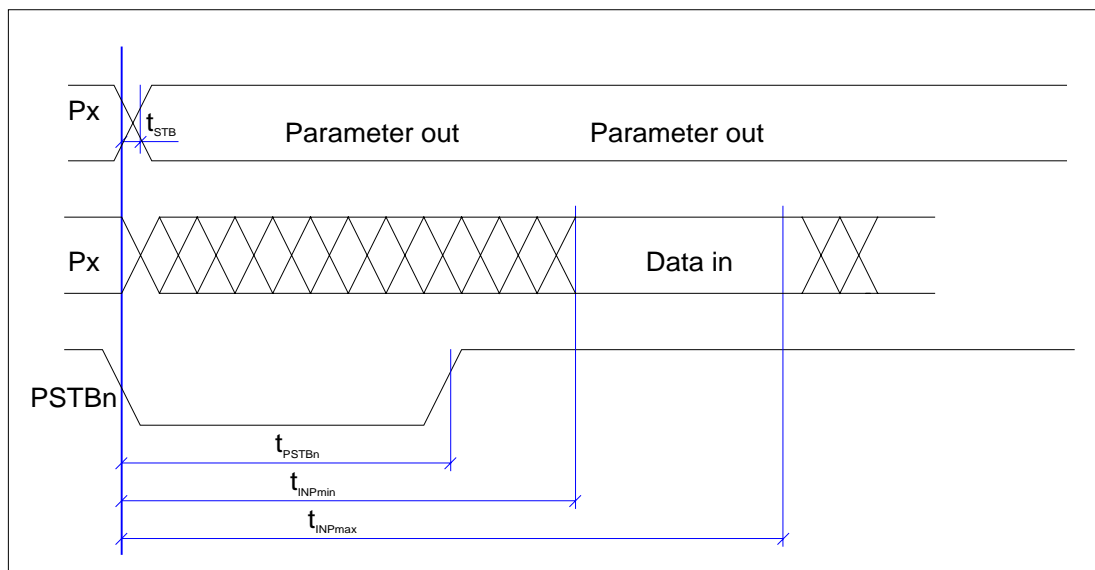

Fig. 3: Timing of data transfer at parameter port P3, ..., P0 relative to strobe PSTBn

The following table specifies the timing parameters relating to fig. 3:

Symbol	Parameter	min.	max.	Unit	Note
tSTB	Delay PSTBn HL-edge to Px output data valid		1.5	µs	
tPSTBn	PSTBn strobe width	6	6.8	µs	1
tINP	Input data valid time window	10.5	12.5	µs	2

Notes:

- 1 Pulse width depends substantially on value of external pull-up resistor
- 2 Timing reference is PSTBn HL-edge.
Applies only to parameter port set to 'input' operation

The dc-parameters of the parameter port pins P3, ..., P0 are specified as follows:

Symbol	Parameter	min.	max.	Unit	Note
IOUTLO	Sink current @ output L	10		mA	VOUT = 1V
IOUTH1	Leakage current @ output off	- 10	10	µA	VOUT = 5V
IOUTH17	Leakage current @ output off; pull-up current source off	- 1	1	µA	VOUT = 5V; IO-conf. = 7
IINLO	Input current @ VIN = 1V	- 5	- 20	µA	1
VSCHLT	Input threshold voltage	2.5	3.5	V	2
VIN	Acceptable input voltage @ output off	- 0.3	40	V	

Notes:

- 1 The passive high-side current-source provides an about constant input current @
0V <= VIN <= 4V
- 2 No hysteresis implemented

Though equipped for bidirectional data transfer as D3, ..., D0, the parameter port is nevertheless less flexible than the data port.

Note the following differences:

- ik) The parameter port is set portwise, the data port bitwise by the IO-configuration code;
- il) The parameter port can only be set to either 'output' or 'input'. A bidirectional behaviour within a strobe cycle is not possible;
- im) The parameter port is set to 'output' as a rule; the only exception occurs in case of IO-configuration 7 and a master data request, which set it to 'input'.

To govern the data transfer at the parameter port P3, ..., P0 strobe pin PSTBn is equipped with a low-side open-drain output switch plus a passive high-side current source with a nom. 10 µA pull-up current capability. Typically the PSTBn-strobe width is about 6 µs, see fig. 3. (However to simplify and shorten the component test time of the slave device, the PSTBn pin is also used as an input. Input low pulses of more than 50 µs each will step and cycle the device through 3 different testmodes beyond the regular operation as described in this datasheet.)

The dc- and timing parameters of strobe pin PSTBn are specified as follows:

Symbol	Parameter	min.	max.	Unit	Note
IOUTLO	Sink current @ output L	10		mA	VOUT = 1V
IOUTH1	Leakage current @ output off	- 10	10	µA	VOUT = 5V
IINLO	Input current @ VIN = 1V	- 5	- 20	µA	1
VSCHLT	Input threshold voltage	1.5	3.5	V	2
VIN	Acceptable input voltage @ output off	- 0.3	40	V	
tNOTM	PSTBn L-phase width, not triggering testmode		35	µs	
tTM	PSTBn L-phase width, triggering testmode	50		µs	
CPINEXT	Stray capacitance		20	pF	

Notes:

- 1 PSTBn is equipped with an on-chip pull-up current source, which ensures a sufficiently fast LH-edge upon output switch-off in open-pin condition, to prevent erroneous testmode triggering.
If PSTBn has an external load connected to it, an additional external pull-up resistor may be needed to prevent erroneous testmode triggering upon output switch-off
- 2 No hysteresis implemented

Operation status pins LED1 and LED2

Pins LED1 and LED2 are both equipped with a low-side open-drain output switch plus a passive high-side current source with a nom. 10 µA pull-up current capability. They will each have an LED load connected to UOUT, which will flag the operation status of the slave device, according to the following table:

Output LED1	Output LED2	Flagging Priority	Slave Device Operation Status	Reason
(green LED connected)	(red LED connected)	(1 = highest, ..., 4 = lowest)		
off	off		Supply voltage off	No supply voltage
on	off		Regular operation	
off	on	4	No Data Communication	Regular, non-zero slave address coded; data comm. watchdog triggered
blinks	on	3	No regular slave address coded	Slave address = default zero
blinks	blinks (alternating with LED1)	2	Hardware failure in sensor / acuator circuitry	Input PFAULT = L
off	blinks	1	External RESET or Overload at UOUT pin	DSTBn = L to RESET, or UOUT switched-off due to overload

(LED1 and LED2 both also feature an input stage, to simplify component test and shorten test time of the slave device.)

The dc- and timing parameters of pins LED1 and LED2 are specified as follows:

Symbol	Parameter	min.	max.	Unit	Note
I _{LED}	Sink current @ output L	10		mA	V _{OUT} = 1V
I _{OUTH1}	Leakage current @ output off	- 10	10	µA	V _{OUT} = 5V
V _{IN}	Acceptable input voltage @ output off	- 0.3	40	V	
f _{BLINK}	Blinking frequency	2	3	Hz	

Data Communication Watchdog

AS2702 is equipped with a watchdog timer to supervise data communication by monitoring the strobe signals at pins DSTB_n and PSTB_n.

If a parameter or data strobe is not followed by a consecutive strobe within a time period of 50 ... 100 ms, the watchdog is triggered and initiates a 'soft' reset, see section 'Reset'

RESET

There are 2 categories of reset-events, leading to 2 slightly different reset-conditions of the slave device:

- 1) a 'hard' reset taking place at power-up and power-down of supply-voltages U_{5R} and U_{OUT}.
At power-up the slave device leaves reset-condition as soon as U_{5R} has passed 3.75V and U_{OUT} has passed V_{COMOFF} = nom. 10V.
At power-down the slave device is forced into reset-condition as soon as U_{5R} drops below 3.75V.
(Tolerance of the threshold voltages referred to is -/+ 5%.)
- 2) a 'soft' reset, resulting from one of the following events:
 - 2.1) Data strobe pin DSTB_n is kept L for more than 100 ms;
 - 2.2) Master command 'RESET SLAVE' is received;
 - 2.3) Master command 'RESET BROADCAST' is received;
 - 2.4) The communication watchdog is triggered.

A 'hard' reset event conditions the slave device as follows:

- Internal states (counters, flags, ...) are reset
- The slave device's receiver is desynchronized from the AS-interface bus
- The low-side open-drain output stages at ports D3, ..., D0 and ports P3, ..., P0 are switched off
- Any test-mode will be cancelled.

A 'soft' reset has the following consequences:

- A regular, nominal 6µs L-phase strobe is generated on both the DSTB_n and PSTB_n pin
- The low-side open-drain output stages at ports D3, ..., D0 and ports P3, ..., P0 are switched off
- Internal states (counters, flags, ...) are reset, however the following states and operations are not affected:
 - the timer function which controls blinking of LED1 and LED2
 - the data communication watchdog
 - any testmode
 - any EEPROM write operation.

Remark:

If UOUT drops below $V_{COMOFF} = \text{nom. } 10V$ data communication with the AS-interface bus is aborted by the receiver or transmitter of the slave device. As long as U5R does not drop below 3.75V in this situation, no 'hard' reset takes place; however the data communication watchdog will be triggered (unless disabled) and a 'soft' reset will result.

EEPROM

AS2702 has a 16 x 8 Bits serial interface EEPROM on board to store the slave unit's address and set-up data in a non-volatile fashion.

The EEPROM stores the following data:

EEPROM-Address	Data	Relevant Nr. of bits	Programmed by	Note
0, 1	Slave Address	5 + 1	Master (Initialization)	1
2	Settings (EID1)	4	Master (Initialization)	
3	Settings (IO-Conf.)	5	Slave unit manufacturer	
4	Settings (ID)	5	Slave unit manufacturer	
5	Settings (EID2)	5	Slave unit manufacturer	
6	Settings (Control-Code)	5	Slave unit manufacturer	

Note

- 1 6 Bits (A4, ..., A0 + Sel-bit) in extended address mode: 62 slaves addressable;
5 Bits (A4, ..., A0) in non-extended address mode: 31 slaves addressable

Obviously the capacity of the EEPROM is only partially used.

Reading and writing of the EEPROM is performed bitwise and through temporary, volatile registers.

Writing of data from the volatile register into the EEPROM takes about 10 ms per byte, whereas reading takes less than 1 ms per byte.

Upon RESET the EEPROM info is read into temporary registers, including the slave's address which has been written redundantly into EEPROM locations 0 and 1 before.

The temporary registers receiving the address are compared for similarity; in case of non-similarity – which e.g. may have been caused by a supply voltage dip during address writing – the slave will flag non-regular operation status / slave address zero.

AS-Interface Bus Communication

All slaves connected to an AS-interface bus are sequentially and cyclicly called by the master in a string of individual transactions between the master and each slave unit.

A transaction consists of a 14 bits master request, typically containing the slave's address as well as data or parameter info, and an immediate acknowledging slave response of 7 bits.

The 14 bits master request - apart from Start Bit ST = 0 and End Bit EB = 1 – has the following contents:

- 1 Control Bit CB: CB = 0 stands for data transfer (typ. data or parameters)
CB = 1 identifies command-type requests
- 5 Address Bits: A4, ..., A0
- 5 Information Bits: I4, ..., I0 (typ. data or parameters)
- 1 Parity Bit PB.

AS2702 allows for up to 62 slaves on the same AS-interface bus; this requires a slave address extended to 6 bits, hence an extra bit beyond A4, ..., A0.

Information bit I3 is used as the 6th address bit in this so-called extended address mode. It is called Sel-bit, as it is perceived as to select between A-slave (Sel = 0) and B-slave (Sel = 1) at address location A4, ..., A0.

In non-extended address mode AS2702 is addressed with A4, ..., A0 only - for a max. total of 31 slaves per AS-interface bus system, and is system compatible with existing slave device AS2701A.

The 7 bits slave response – apart from Start Bit ST = 0 and End Bit EB = 1 – has the following contents:

- 4 Information Bits: I4, ..., I0 (typ. data or parameters)
- 1 Parity Bit PB.

Detailed descriptions of all types of master requests and corresponding slave responses can be found in AS-Interface Specification V2.11, obtainable from the AS-International Association (D) or its local representative, see section "Application Support".

Application Example

Sensor/actuator circuit supplied by the ASI Slave IC (UOUT) for supply current needs ≤ 50 mA.

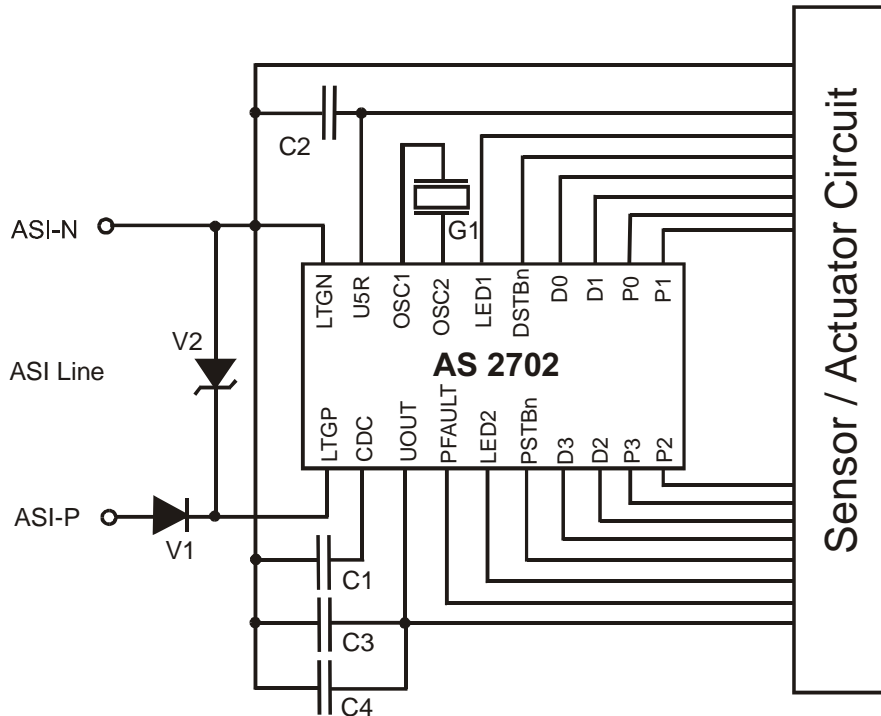

- C1 = 100 nF / 35 V
- C2 = 100 nF / 6 V
- C3 = 10...470 μ F / 30 V
- C4 = 22...100 nF / 30 V
- V1 = 1N4002 or equivalent
- V2 = TGL 41-39A or equivalent
- G1 = AS-Interface Crystal 5.333 MHz

AS-Interface Quartz 5.333 MHz

AS2702 works fine with the following crystal types:

Citizen CM 309
Philips SQ 4849

AS-Interface quartz crystals are available from:

Endrich GmbH
Contact: Axel Gensler
Hauptstr. 56
D-72202 Nagold
Tel.: +49-7452-6007-31
Fax: +49-7452-6007-70
Email: a.gensler@endrich.com

Geyer electronic
Contact: Jürgen Blank
Camerloherstr. 71
D-80689 München
Tel.: +49-89-546868-13
Fax: +49-89-546868-90

Kinseki Europe GmbH
Contact: Dirk Holstein
Schirmer Str. 76
D-40211 Düsseldorf
Tel.: +49-211-36815-33
Fax: +49-211-36815-10
Email: dholstein@kinseki.de

Rutronik Elektronische Bauelemente GmbH
Contact: Jürgen Tischhauser
Industriestrasse 2
D-75228 Ispringen / Pforzheim
Tel.: +49-7231-801-543
Fax: +49-7231-801-633
Email: juergen_tischhauser@rutronik.com

Application Support

For general information and documentation on the AS-Interface concept you may contact one of the following AS-Interface Associations:

AS-International Association
Contact: Rolf Becker
Zum Taubengarten 52
D-63571 Gelnhausen
Tel.: +49-6051-473212
Fax: +49-6051-473282
Email: as-interface@t-online.de

AS-Interface Switzerland
Contact: Rainer Schnaidt
Bittertenstraße 15
CH-4702 Oensingen
Tel.: +41-62-388-2567
Fax: +41-62-388-2525
Email: rainer.schnaidt@fho.ch

AS-Interface France
Contact: Gilles Mazet
5 rue Nadar
F-92566 Rueil Malmaison cedex
Tel.: +33-1-41-298294
Fax: +33-1-41-298482
Email: gilles_mazet@mail.schneider.fr

AS-Interface Italy
Contact: Maurizio Ghizzoni
Via G.B. Barinetti, 1
I-20145 Milano
Tel.: +39-02-66761
Fax: +39-02-6676-3491
Email: maurizio.ghizzoni@siemens.it

AS-Interface The Netherlands
Contact: Andre Braakman
Boerhaavelaan 40
NL-2700 AD Zoetermeer
Tel.: +31-79-353-1269
Fax: +31-79-353-1365
Email: ABA@FME.NL

AS-Interface Great Britain
Contact: Geoff Hodgkinson
1 West Street
GB-PO 14 4DH Titchfield, Hampshire
Tel.: +44-1329-511882
Fax: +44-1329-512063
Email: asi_uk@gghcomms.demon.co.uk

AS-Interface USA
Contact: Michael Bryant
16101 N. 82nd Street, Suite 3B
USA-85260 Scottsdale, Arizona
Tel.: +1-480-368-9091
Fax: +1-480-483-7202
Email: mbryant@goodnet.com

AS-Interface Belgium
Contact: Maurice de Smedt
Avenue Paul Hymanslaan 47
B-1200 Bruxelles-Brussel
Tel.: +32-2-771-3912
Fax: +32-2-771-1264
Email: m.desmedt@udias.be

AS-Interface Sweden
Contact: Lars Mattsson
Karl Nordströms väg 31
SE-43253 Varberg
Tel.: +46-3406-29270
Fax: +46-3406-77190
Email: lars-mattsson@marknadspartnermol.se

Bibliography

ASI: The Actuator-Sensor-Interface for Automation
Edts.: Werner Kriesel, Otto W. Madelung
Carl Hanser Verlag, Munich and Vienna, 1995
ISBN: 3-446-18265-9

Ordering Information

AS2702-20T Package: SOIC 20; delivery: tape & reel
AS2702-16T Package: SOIC 16 W; delivery: tape & reel; no parameter port available
AS2702-20 Package: SOIC 20; delivery: tubes
AS2702-16 Package: SOIC 16 W; delivery: tubes; no parameter port available

This datasheet has been downloaded from:

www.DatasheetCatalog.com

Datasheets for electronic components.



LittleDiode supplies new, hard to find or obsolete electronic components and semiconductors all over the world.

With over two million different components listed you are sure to find the part you need.

Feel free to visit us today at our online store:

LittleDiode.com

Looking forward to providing you with the best possible service.