

## NPN POWER SILICON TRANSISTOR

Qualified per MIL-PRF-19500/412

### Devices

2N3846

2N3847

### Qualified Level

JAN  
JANTX  
JANTXV

### MAXIMUM RATINGS

Ratings	Symbol	2N3846	2N3847	Units
Collector-Emitter Voltage	$V_{CEO}$	200	300	Vdc
Collector-Base Voltage	$V_{CBO}$	300	400	Vdc
Emitter-Base Voltage	$V_{EBO}$	10		Vdc
Collector Current	$I_C$	20		Adc
Total Power Dissipation	$P_T$	@ $T_A = +25^{\circ}\text{C}$ <sup>(1)</sup>	4.0	W
		@ $T_C = +100^{\circ}\text{C}$ <sup>(2)</sup>	150	W
Operating & Storage Temperature Range	$T_{op}, T_{stg}$	-65 to +200		$^{\circ}\text{C}$

### THERMAL CHARACTERISTICS

Characteristics	Symbol	Max.	Unit
Thermal Resistance, Junction-to-Case	$R_{\theta JC}$	0.5	$^{\circ}\text{C}/\text{W}$

1) Derate linearly 26.6 mW/ $^{\circ}\text{C}$  to +175 $^{\circ}\text{C}$

2) Derate linearly 2 W/ $^{\circ}\text{C}$  to +175 $^{\circ}\text{C}$

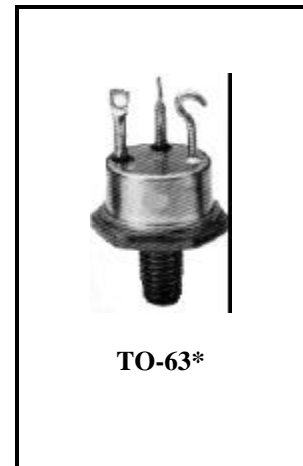

\*See Appendix A for Package Outline

### ELECTRICAL CHARACTERISTICS

Characteristics	Symbol	Min.	Max.	Unit
-----------------	--------	------	------	------

### OFF CHARACTERISTICS

Collector-Emitter Breakdown Voltage $I_C = 200 \text{ mAdc}; I_B = 0$	2N3846 2N3847	$V_{(BR)CEO}$	200 300	Vdc
Collector-Emitter Cutoff Current $V_{CE} = 300 \text{ Vdc}; V_{BE} = 0$ $V_{CE} = 400 \text{ Vdc}; V_{BE} = 0$	2N3846 2N3847	$I_{CES}$	2 2	mAdc
Collector-Emitter Cutoff Current $V_{CE} = 200 \text{ Vdc}; I_B = 0$ $V_{CE} = 300 \text{ Vdc}; I_B = 0$	2N3846 2N3847	$I_{CEO}$	5 5	mAdc
Emitter-Base Cutoff Current $V_{BE} = 10 \text{ Vdc}; I_C = 0$		$I_{EBO}$	250	$\mu\text{Adc}$

**ELECTRICAL CHARACTERISTICS (con't)**

Characteristics	Symbol	Min.	Max.	Unit
<b>ON CHARACTERISTICS</b> <sup>(3)</sup>				
Forward-Current Transfer Ratio $I_C = 1 \text{ Adc}; V_{CE} = 3.0 \text{ Vdc}$ $I_C = 5 \text{ Adc}; V_{CE} = 3.0 \text{ Vdc}$ $I_C = 10 \text{ Adc}; V_{CE} = 3.0 \text{ Vdc}$	$h_{FE}$	70 40 12	240 60	
Base-Emitter Voltage $V_{CE} = 3 \text{ Vdc}; I_C = 10 \text{ Adc}$	$V_{BE}$		1.20	Vdc
Base-Emitter Saturated Voltage $I_B = 1.6 \text{ Adc}; I_C = 10 \text{ Adc}$	$V_{BE(sat)}$		1.30	Vdc
Collector-Emitter Saturated Voltage $I_B = 1.6 \text{ Adc}; I_C = 10 \text{ Adc}$	$V_{CE(sat)}$		0.75	Vdc

**DYNAMIC CHARACTERISTICS**

Magnitude of Common-Emitter Small-Signal Short-Circuit Forward Current Transfer Ratio $I_C = 1.0 \text{ Adc}, V_{CE} = 10 \text{ Vdc}, f = 1 \text{ MHz}$	$ h_{fe} $	10	35	
Small-Signal Short-Circuit Forward Current Transfer Ratio $I_C = 5 \text{ Adc}, V_{CE} = 10 \text{ Vdc}, f = 1 \text{ kHz}$	$h_{fe}$	50	250	
Output Capacitance $V_{CB} = 10 \text{ Vdc}, I_E = 0, 100 \text{ kHz} \leq f \leq 1.0 \text{ MHz}$	$C_{obo}$		750	pF

**SWITCHING CHARACTERISTICS**

Turn-On Time $V_{BE(off)} \sim -7.5 \text{ Vdc}; I_C = 10 \text{ Adc};$ $I_{B1} = 2 \text{ Adc}; I_{B2} = -2 \text{ Adc}; R_L = 15\Omega$	$t_{on}$		4	$\mu\text{s}$
Turn-Off Time $V_{BE(off)} \sim -7.5 \text{ Vdc}; I_C = 10 \text{ Adc};$ $I_{B1} = 2 \text{ Adc}; I_{B2} = 2 \text{ Adc}; R_L = 15\Omega$	$t_{off}$		7	$\mu\text{s}$

**SAFE OPERATING AREA**

<b>DC Tests</b> $T_C = +100^\circ\text{C}; V_{CE} = 0 \text{ Vdc}, I_C = 0 \text{ Adc}$ (See Figure 3 on Mil-PRF-19500/412)
<b>Test 1</b> $V_{CE} = 7.5 \text{ Vdc}; I_C = 20 \text{ Adc}; t_p = 1.0 \text{ s}; 1 \text{ cycle}$
<b>Test 2</b> $V_{CE} = 200 \text{ Vdc}; I_C = 100 \text{ mAdc}; t_p = 1.0 \text{ s}, 1 \text{ cycle}$
<b>Test 3</b> $V_{CE} = 58 \text{ Vdc}; I_C = 1.0 \text{ Adc}; t_p = 1.0 \text{ s}, 1 \text{ cycle}$
<b>Burnout by Pulsing (2N3847 only)</b> $T_C = +100^\circ\text{C}; V_{CE} = 300 \text{ Vdc}; I_C = 20 \text{ mAdc}; t_p = 1.0 \text{ s}, 1 \text{ cycle}$
<b>Unclamped Inductive Sweep</b> $T_C = +100^\circ\text{C}; I_C = 20 \text{ Adc}; I_B = 2 \text{ Adc}$ (See Figure 4 on Mil-PRF-19500/412)
<b>Clamped Inductive Sweep</b> $T_C = +100^\circ\text{C}; I_C = 20 \text{ Adc}; I_B = 2 \text{ Adc}$ (See Figure 5 on Mil-PRF-19500/412)

3) Pulse Test: Pulse Width = 300 $\mu\text{s}$ , Duty Cycle  $\leq 2.0\%$ .



LittleDiode supplies new, hard to find or obsolete electronic components and semiconductors all over the world.

With over two million different components listed you are sure to find the part you need.

Feel free to visit us today at our online store:

[LittleDiode.com](http://LittleDiode.com)

Looking forward to providing you with the best possible service.