



**3507J**

3507J

2

OPERATIONAL AMPLIFIERS

## **Fast-Slewing OPERATIONAL AMPLIFIER**

### **FEATURES**

- 120V/ $\mu$ sec SLEW RATE
- 20MHz GAIN-BANDWIDTH PRODUCT
- INTERCHANGEABLE WITH 741 TYPES

### **DESCRIPTION**

Burr-Brown model 3507J is intended for use in circuits requiring fast transient response-pulse amplifiers, D/A converters, comparators, fast followers, etc. Key parameters such as slew rate, settling time and bandwidth are orders of magnitude better than for most other IC op amps.

The 3507J is compensated to allow faster slewing and greater bandwidth for gains of 3 or more. For gains greater than 3, the gain rolloff is 6dB/octave. By use of a single external 20pF compensation capacitor the 3507J can be stabilized at all gains including unity. In addition, by use of an alternate compensation technique, it is possible to stabilize the 3507J at unity gain without sacrificing its faster slew rate.

The 3507J is pin-compatible with other standard IC op amps while offering greater speed and higher output current. It also is input-and output-protected to prevent damage if the output is shorted to common, or the input is shorted to supply voltage.

# SPECIFICATIONS

## ELECTRICAL

Typical at  $\pm 15\text{VDC}$  and  $+25^\circ\text{C}$  unless otherwise noted.

MODEL	3507J	
	TYPICAL	GUARANTEED
<b>OPEN-LOOP GAIN, DC</b>		
No Load	90dB	
2k $\Omega$ Load	83dB	77dB
<b>RATED OUTPUT</b>		
Voltage (1k $\Omega$ load)	$\pm 12\text{V}$	$\pm 10\text{V}$
Current	$\pm 20\text{mA}$	$\pm 10\text{mA}$
<b>DYNAMIC RESPONSE</b>		
Small Signal Bandwidth (0dB)	—	—
Gain-Bandwidth Product ( $A_{CL} = 10$ )	20MHz	1.2MHz
Full Power Bandwidth	1.6MHz	80V/ $\mu\text{sec}$
Slew Rate	120V/ $\mu\text{sec}$	80V/ $\mu\text{sec}$
Settling Time (0.1%)	200nsec	50nsec
Rise Time (10-90%, small signal)	25nsec	50nsec
Overshoot	—	—
<b>INPUT OFFSET VOLTAGE</b>		
Initial (without adjust) at $+25^\circ\text{C}$	$\pm 5\text{mV}$	$\pm 10\text{mV}$
Over Temperature (avg. $0^\circ\text{C}$ to $+70^\circ\text{C}$ ) vs Supply Voltage vs Time	$\pm 30\mu\text{V}/^\circ\text{C}$ $\pm 30\mu\text{V}/\text{V}$ $\pm 50\mu\text{V}/\text{mo}$	$\pm 14\text{mV}$ $200\mu\text{V}/\text{V}$
<b>INPUT BIAS CURRENT</b>		
Initial at $+25^\circ\text{C}$	$+50\text{nA}$	$+250\text{nA}$
Over Temperature (avg. $0^\circ\text{C}$ to $+70^\circ\text{C}$ )	$\pm 0.5\text{nA}/^\circ\text{C}$	$+500\text{nA}$
<b>INPUT DIFFERENCE CURRENT</b>		
Initial at $+25^\circ\text{C}$	$\pm 20\text{nA}$	$\pm 50\text{nA}$
Over Temperature (avg. $0^\circ\text{C}$ to $+70^\circ\text{C}$ )	$\pm 0.1\text{nA}/^\circ\text{C}$	$\pm 100\text{nA}$
<b>INPUT IMPEDANCE</b>		
Differential	100M $\Omega$    3pF	40M $\Omega$
Common-Mode	1000M $\Omega$    3pF	
<b>INPUT VOLTAGE RANGE</b>		
Common-Mode (linear operation)	$\pm 12\text{V}$	$\pm 10\text{V}$
Differential (between inputs)	$\pm 15\text{V}$	$\pm \text{Supply}$
Absolute Max (either input)		$\pm \text{Supply}$
Common-Mode Rejection	90dB	74dB
<b>POWER SUPPLY</b>		
Rated Voltage		$\pm 15\text{VDC}$
Voltage Range, derated	$\pm 8\text{V}$ to $\pm 20\text{V}$	
Current, quiescent	$\pm 4\text{mA}$	$\pm 8\text{mA}$
<b>TEMPERATURE RANGE</b>		
Specifications		$0^\circ\text{C}$ to $+70^\circ\text{C}$
Operating		$-25^\circ\text{C}$ to $+85^\circ\text{C}$
Storage		$-65^\circ\text{C}$ to $+150^\circ\text{C}$

## MECHANICAL

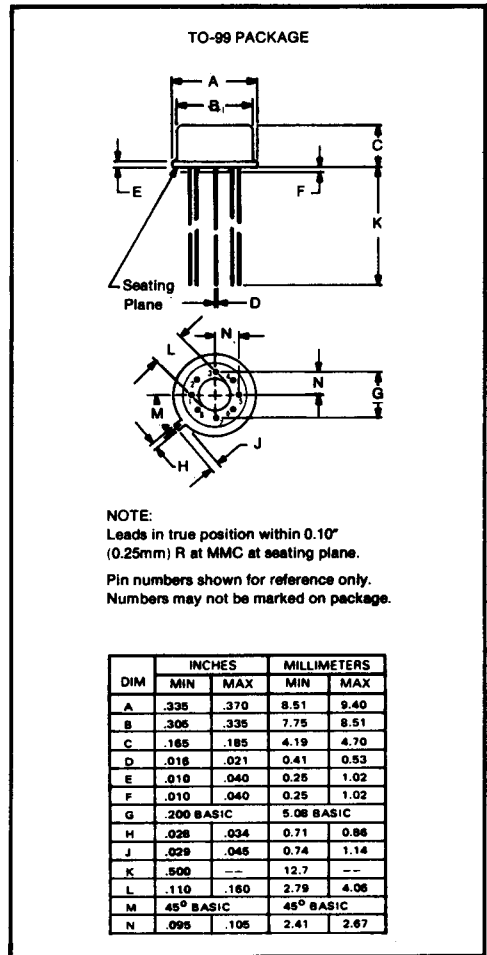

## CONNECTION DIAGRAM

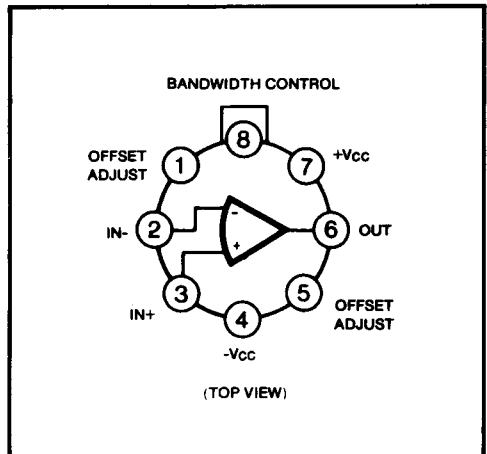

This datasheet has been downloaded from:

[www.DatasheetCatalog.com](http://www.DatasheetCatalog.com)

Datasheets for electronic components.



LittleDiode supplies new, hard to find or obsolete electronic components and semiconductors all over the world.

With over two million different components listed you are sure to find the part you need.

Feel free to visit us today at our online store:

[LittleDiode.com](http://LittleDiode.com)

Looking forward to providing you with the best possible service.