

March 1996

Features

- Devices QML Qualified in Accordance with MIL-PRF-38535
- Detailed Electrical and Screening Requirements are Contained in SMD# 5962-9XXXX and Intersil' QM Plan
- Radiation Hardened EPI-CMOS
 - Total Dose 1×10^5 RAD(Si)
 - Latch-Up Immune $> 1 \times 10^{12}$ RAD (Si)/s (Note 1)
- Low Propagation Delay Time
 - Typical CMOS to TTL Pre-RAD 40ns
 - Typical CMOS to TTL Post 100K RAD 40ns
 - Typical TTL to CMOS Pre-RAD 50ns
 - Typical TTL to CMOS Post 100K RAD 50ns
- Low Standby Power
- +10V CMOS and +5V TTL Power Supply Inputs
- Eight Non-inverting Three-State Input/Output Channels
- No External TTL Input Pull-Up Resistors Required
- High TTL Sink Current
- Equivalent to Sandia SA2996
- Military Temperature Range -55°C to $+125^{\circ}\text{C}$

Description

The Intersil HS-3374RH is a radiation hardened 8-bit bidirectional level converter designed to interface CMOS logic levels with TTL logic levels in radiation hardened bus oriented systems. The HS-3374RH is fabricated using a radiation hardened EPI-CMOS process and features eight parallel bidirectional buffer/level converters.

Two control inputs, ENABLE and DISABLE, are used to determine the direction of data flow, and to set both the inputs and outputs in the high impedance state. The control inputs may be driven by either TTL or CMOS logic drivers capable of sinking one standard TTL load.

The HS-3374RH is a non-inverting version of the industry standard CD40116. The non-inverting outputs of the HS-3374RH reduce PC board chip count by eliminating the need to restore data back to a non-inverted format.

NOTE:

1. For operation at 10V and transient levels above 1×10^{10} RAD (Si)/s, please refer to Application Note 401.

Pinout

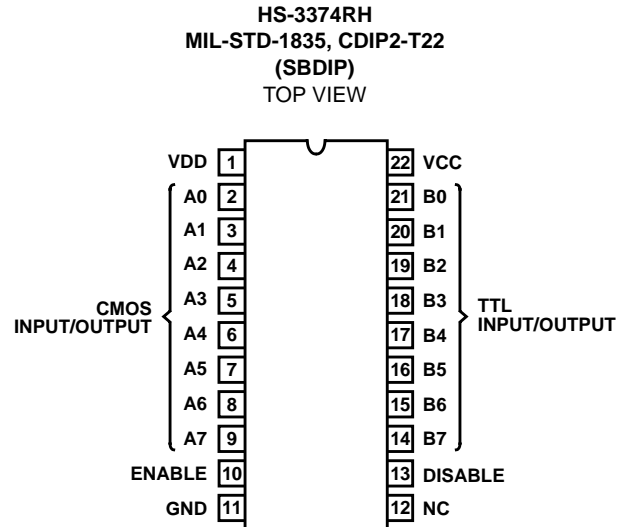

Functional Diagram

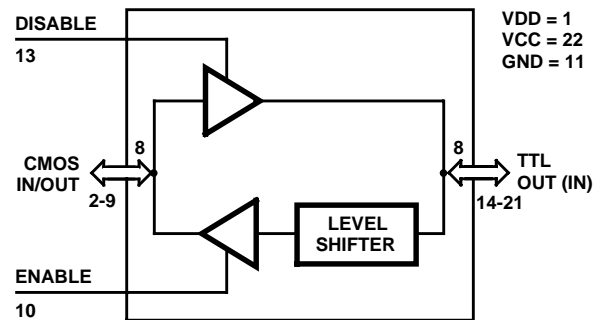

Ordering Information

PART NUMBER	TEMPERATURE RANGE	SCREENING LEVEL	PACKAGE
5962R9XXXX01QRC	-55°C to $+125^{\circ}\text{C}$	MIL-PRF-38535 Level Q	22 Lead SBDIP
5962R9XXXX01VRC	-55°C to $+125^{\circ}\text{C}$	MIL-PRF-38535 Level V	22 Lead SBDIP
HS1-3374 (SAMPLE)	$+25^{\circ}\text{C}$	Sample	22 Lead SBDIP

Specifications HS-3374RH

Absolute Maximum Ratings

Supply Voltage+11.0V
I/O Voltage Applied GND-0.3V to VDD+0.3V
Storage Temperature Range -65°C to +150°C
Junction Temperature +175°C
Lead Temperature (Soldering 10s) +300°C
ESD Classification Class 1

Thermal Information

Thermal Resistance (Typical)	θ_{JA} (°C/W)	θ_{JC} (°C/W)
SBDIP Package	74.8	12.3
Maximum Package Power Dissipation at +125°C		
SBDIP Package	.067W	
If Device Power Exceeds Package Dissipation Capability, Provide Heat Sinking or Derate Linearly at the Following Rate:		
SBDIP Package	13.4mW/°C	

CAUTION: Stresses above those listed in "Absolute Maximum Ratings" may cause permanent damage to the device. This is a stress only rating and operation of the device at these or any other conditions above those indicated in the operational sections of this specification is not implied.

Operating Conditions

Operating Voltage Range	VDD +9.5V to +10.5V	Input Low Voltage (CMOS) GND to 1V
	VCC +4.75V to +5.25V	Input High Voltage (CMOS) VDD-1.0V to VDD
Operating Temperature Range	 -55°C to +125°C	Input Low Voltage (TTL) 0.8V
Input Voltage Range			Input High Voltage (TTL) 2.8V
Data Inputs (CMOS)	GND-0.3 to VDD+0.3		
Data Inputs (TTL)	GND-0.3 to VCC+0.3		
Enable, Disable Inputs	GND-0.3 to VDD+0.3		

TABLE 1. DC ELECTRICAL PERFORMANCE CHARACTERISTICS

PARAMETER	SYMBOL	CONDITIONS	GROUP A SUBGROUPS	TEMPERATURE	LIMITS		UNITS
					MIN	MAX	
ENABLE AND DISABLE IINPUTS							
Input Leakage Current	I _{IH} CMOS	VDD = 10.5V, VCC = 5.25V, VIN = 10.5V, Floating Outputs	1, 2, 3	-55°C, +25°C, +125°C	-	1	μA
TTL INPUT TO CMOS OUTPUTS							
Input Leakage Current	I _{IH} I _{IH}	VDD = 10.5V, VCC = 5.25V, VIN = 0.8V, Other Inputs at 2.8V	1, 2, 3	-55°C, +25°C, +125°C	-1	-	μA
		VDD = 10.5V, VCC = 5.25V, VIN = 2.8V, other Inputs = 0.8V	1, 2, 3	-55°C, +25°C, +125°C	-	1	μA
High Level Output Voltage	VOH	VDD = 9.5V, VCC = 4.75V, VIH = 2.8V, VIL = 0.8V, IOH = -2.0mA	1, 2, 3	-55°C, +25°C, +125°C	9	-	V
Low level output Voltage	VOL	VDD = 10.5V, VCC = 5.25V, VIH = 2.8V, VIL 0.8V, IOL = 2.0mA	1, 2, 3	-55°C, +25°C, +125°C	-	0.5	V
CMOS to TTL OUTPUTS							
High Level Output Voltage	VOH	VDD = 9.5, VCC = 4.75V, VIH = 8.5V, VIL = 1.0V, IOH = -2.0mA	1, 2, 3	-55°C, +25°C, +125°C	3	-	V
Low Level Output Voltage	VOL	VDD = 10.5V, VCC = 5.25V, VIH = 9.5V, VIL = 1.0V, IOL = 11mA	1, 2, 3	-55°C, +25°C, +125°C	-	0.4	V
Output Leakage Current	IOZL	VDD = 10.5V, VCC = 5.25V, VIN = 0V, All other pins high	1, 2, 3	-55°C, +25°C, +125°C	-10	-	μA
	IOZH	VDD = 10.5V, VCC = 5.25V, VIN = 2.8V, All other pins at GND	1, 2, 3	-55°C, +25°C, +125°C	-	10	μA

Specifications HS-3374RH

TABLE 1. DC ELECTRICAL PERFORMANCE CHARACTERISTICS (Continued)

PARAMETER	SYMBOL	CONDITIONS	GROUP A SUBGROUPS	TEMPERATURE	LIMITS		UNITS
					MIN	MAX	
Functional Tests	FT	CMOS: 1.) VDD = 10.5V, VCC = 5.25V 2.) VDD = 9.5V, VCC = 4.75V, VIH = VDD-1V, VIL = 1V TTL: 1.) VDD = 10.5V, VCC = 5.25V 2.) VDD = 9.5V, VCC = 4.75V, VIH = 2.8V, VIL = 0.8V	7, 8A, 8B	-55°C, +25°C, +125°C	-	-	-
Static Current 1	SIDD1	VDD = 10.5V, VCC = 5.25V, EN = 2.8V, DISABLE = 2.8V, Floating Outputs	1, 2, 3	-55°C, +25°C, +125°C	-	300	μA
Static Current 2	SIDD2	VDD = 10.5V, VCC = 5.25V, EN = 0V, DISABLE = 2.8V, Floating Outputs	1, 2, 3	-55°C, +25°C, +125°C	-	100	μA
Static Current	SICC	VDD = 10.5, VCC = 5.25V, EN = 0V, DISABLE = 2.8V, Floating Output, Measure VCC pin	1, 2, 3	-55°C, +25°C, +125°C	-	5	μA

TABLE 2. AC ELECTRICAL PERFORMANCE CHARACTERISTICS

PARAMETER	SYMBOL	GROUP A SUB-GROUPS	TEMPERATURE	LIMITS		UNITS
				MIN	MAX	
Propagation Delay Times CMOS/TTL Data In to Data Out	TPHLC	9, 10, 11	-55°C, +25°C, +125°C	-	40	ns
Propagation Delay Times CMOS Data In to Data Out	TPHCT	9, 10, 11	-55°C, +25°C, +125°C	-	50	ns
Propagation Delay Times CMOS/TTL Data In to Data Out	TPHLC	9, 10, 11	-55°C, +25°C, +125°C	-	85	ns
Propagation Delay Time TTL/CMOS Data In to Data Out	TPHCT	9, 10, 11	-55°C, +25°C, +125°C	-	70	ns
Transition Time CMOS/TTL Input/Output	TTHLC	9, 10, 11	-55°C, +25°C, +125°C	-	20	ns
Transition Time CMOS/TTL Input/Output	TTHCT	9, 10, 11	-55°C, +25°C, +125°C	-	70	ns
Transition Time CMOS/TTL Input/Output	TTHLC	9, 10, 11	-55°C, +25°C, +125°C	-	50	ns
Transition Time CMOS/TTL Input/Output	TTHCT	9, 10, 11	-55°C, +25°C, +125°C	-	50	ns
Propagation Delay Time TTL/CMOS Enable to CMOS Out	TPHZC	9, 10, 11	-55°C, +25°C, +125°C	-	90	ns
Propagation Delay Time TTL/CMOS Enable to CMOS Out	TPHZC	9, 10, 11	-55°C, +25°C, +125°C	-	90	ns
Propagation Delay Time TTL/CMOS Enable to CMOS Out	TPHZC	9, 10, 11	-55°C, +25°C, +125°C	-	85	ns

Specifications HS-3374RH

TABLE 2. AC ELECTRICAL PERFORMANCE CHARACTERISTICS (Continued)

PARAMETER	SYMBOL	GROUP A SUB-GROUPS	TEMPERATURE	LIMITS		UNITS
				MIN	MAX	
Propagation Delay Time TTL/CMOS Enable to CMOS Out	TPZLTC	9, 10, 11	-55°C, +25°C, +125°C	-	90	ns
Propagation Delay Time CMOS/TTL Disable to TTL Out	TPHZCT	9, 10, 11	-55°C, +25°C, +125°C	-	70	ns
Propagation Delay Time CMOS/TTL Disable to TTL Out	TPZHCT	9, 10, 11	-55°C, +25°C, +125°C	-	130	ns
Propagation Delay Time CMOS/TTL Disable to TTL Out	TPLZCT	9, 10, 11	-55°C, +25°C, +125°C	-	120	ns
Propagation Delay Time CMOS/TTL Disable to TTL Out	TPZLCT	9, 10, 11	-55°C, +25°C, +125°C	-	125	ns

NOTE: Timings are measured with the following conditions: CL = 100pF, VDD = 9.5V, VCC = 4.75V, VIH = 8.5V (2.8V), VIL = 1.0V (0.8V).

TABLE 3. ELECTRICAL PERFORMANCE CHARACTERISTICS

PARAMETER	SYMBOL	CONDITIONS	TEMPERATURE	LIMITS		UNITS
				MIN	MAX	
Input, Output Capacitance	CMOS CI/O	VDD = Open, f = 1MHz, All Measurements Referenced to Device Ground	+25°C	-	13	pF
Input Capacitance	CIN	VDD = Open, f = 1MHz, All Measurements Referenced to Device Ground	+25°C	-	15	pF
Input, Output Capacitance	TTL CI/O	VDD = Open, f = 1MHz, All Measurements Referenced to Device Ground	+25°C	-	17	pF

NOTE: The parameters listed in Table 3 are controlled via design or process parameters and are not directly tested. These parameters are characterized upon initial design release and upon design changes which would affect these characteristics.

Functional Block Diagram

1 OF 8 IDENTICAL CIRCUITS

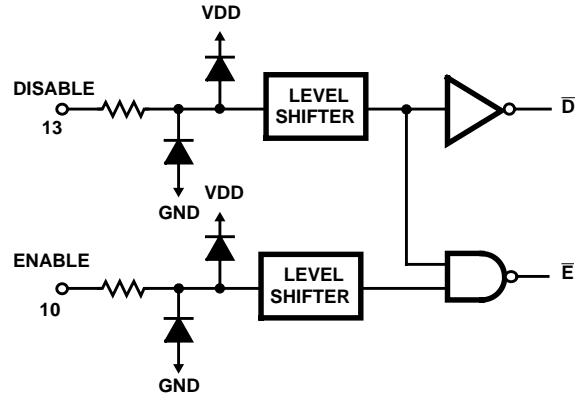
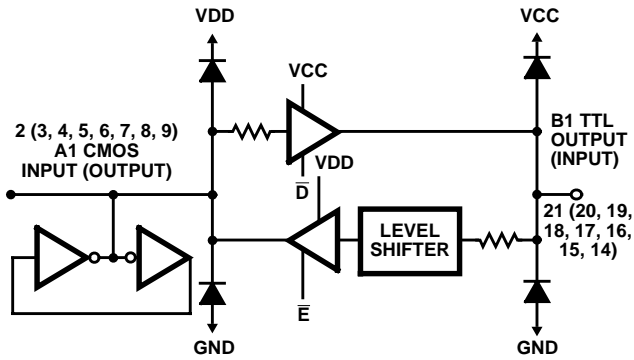

NOTES:

1. Enable and disable are TTL type inputs
2. D and E outputs are common to all 8 channels

INPUT (OUTPUT)		OUTPUT (INPUT)	
DATA	TERMINAL NUMBER	DATA	TERMINAL NUMBER
A0	2	B0	21
A1	3	B1	20
A2	4	B2	19
A3	5	B3	18
A4	6	B4	17
A5	7	B5	16
A6	8	B6	15
A7	9	B7	14

TRUTH TABLE

ENABLE	DISABLE	FUNCTION
X	0	Convert CMOS Level to TTL Level
1	1	Convert TTL Level to CMOS Level
0	1	High Impedance (Z)

0 = Low Level 1 = High Level X = Don't Care
Z = High Impedance on Both CMOS and TTL sides.

NOTE: An important caveat that is applicable to CMOS devices in general is that unused inputs should never be left floating. This rule applies to inputs connected to a three-state bus. The need for external pull-up resistors during three-state bus conditions is eliminated by the presence of regenerative latches on the following HS-3374RH pins: A0 - 7.

The functional block diagram depicts one of these pins with the regenerative latch. When the CMOS driver assumes the high impedance state, the latch holds the bus in whatever logic state (high or low) it was before the three-state condition. A transient drive current of $\pm 1.5\text{mA}$ at $V_{DD}/2 \pm 0.5\text{V}$ for 10ns is required to switch the latch. Thus, CMOS device inputs connected to the bus are not allowed to float during three-state conditions.

* WARNING: Do not activate the Disable input by hardwiring to any TTL input pins. This is an incorrect mode of operation.

HS-3374RH

Metallization Topology

DIE DIMENSIONS:

89.4 mils x 76.0 mils x 14 mils \pm 1 mil

METALLIZATION:

Type: AlSi

Thickness: $8\text{k}\text{\AA} \pm 1\text{k}\text{\AA}$

GLASSIVATION:

Type: SiO₂

Thickness: $11\text{k}\text{\AA} \pm 2\text{k}\text{\AA}$

Metallization Mask Layout

HS-3374RH

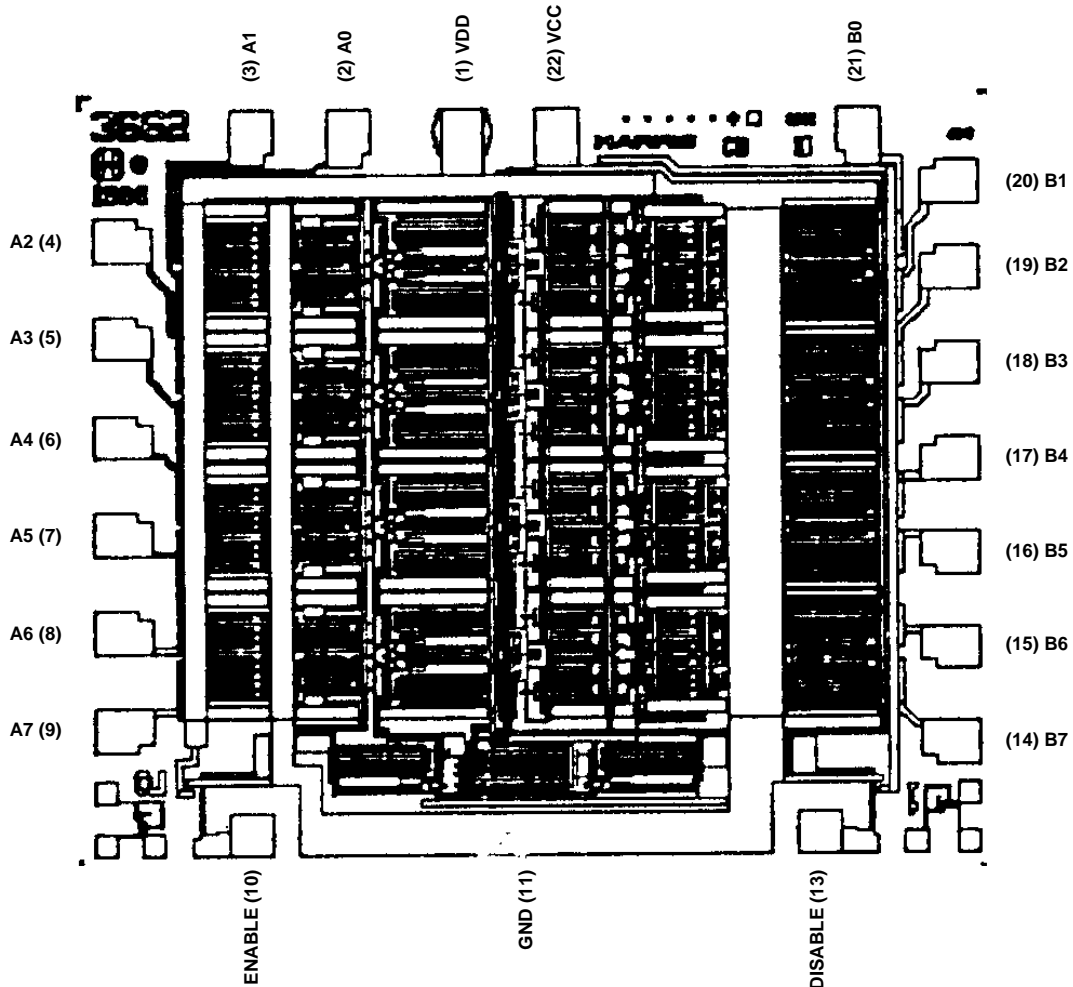

All Intersil semiconductor products are manufactured, assembled and tested under **ISO9000** quality systems certification.

Intersil products are sold by description only. Intersil Corporation reserves the right to make changes in circuit design and/or specifications at any time without notice. Accordingly, the reader is cautioned to verify that data sheets are current before placing orders. Information furnished by Intersil is believed to be accurate and reliable. However, no responsibility is assumed by Intersil or its subsidiaries for its use; nor for any infringements of patents or other rights of third parties which may result from its use. No license is granted by implication or otherwise under any patent or patent rights of Intersil or its subsidiaries.

For information regarding Intersil Corporation and its products, see web site <http://www.intersil.com>

This datasheet has been downloaded from:

www.DatasheetCatalog.com

Datasheets for electronic components.



LittleDiode supplies new, hard to find or obsolete electronic components and semiconductors all over the world.

With over two million different components listed you are sure to find the part you need.

Feel free to visit us today at our online store:

LittleDiode.com

Looking forward to providing you with the best possible service.