

# DATA SHEET

## **74LVT273** 3.3V Octal D flip-flop

Product specification  
Supersedes data of 1994 May 11  
IC23 Data Handbook

1998 Feb 19

# 3.3V Octal D flip-flop

# 74LVT273

## FEATURES

- Eight edge-triggered D-type flip-flops
- Buffered common clock
- Buffered asynchronous Master Reset
- Output capability: +64mA/-32mA
- TTL input and output switching levels
- Input and output interface capability to systems at 5V supply
- Bus-hold data inputs eliminate the need for external pull-up resistors to hold unused inputs
- Power-up reset
- Live insertion/extraction permitted
- No bus current loading when output is tied to 5V bus
- Latchup protection exceeds 500 mA per JEDEC Std 17
- ESD protection exceeds 2000V per Mil Std 883 Method 3015 and 200V per Machine Model.

## DESCRIPTION

The LVT273 is a high-performance BiCMOS product designed for  $V_{CC}$  operation at 3.3V.

This device has eight edge-triggered D-type flip-flops with individual D inputs and Q outputs. The common buffered Clock (CP) and Master Reset ( $\overline{MR}$ ) inputs load and reset (clear) all flip-flops simultaneously.

The register is fully edge-triggered. The state of each D input, one setup time before the Low-to-High clock transition, is transferred to the corresponding flip-flop's Q output.

All outputs will be forced Low independent of Clock or Data inputs by a Low voltage level on the  $\overline{MR}$  input. The device is useful for applications where the true output only is required and the CP and  $\overline{MR}$  are common elements.

## QUICK REFERENCE DATA

SYMBOL	PARAMETER	CONDITIONS $T_{amb} = 25^{\circ}\text{C}; \text{GND} = 0\text{V}$	TYPICAL	UNIT
$t_{PLH}$ $t_{PHL}$	Propagation delay CP to Qn	$C_L = 50\text{pF}; V_{CC} = 3.3\text{V}$	3.5 3.5	ns
$C_{IN}$	Input capacitance	$V_I = 0\text{V}$ or $3.0\text{V}$	4	pF

## ORDERING INFORMATION

PACKAGES	TEMPERATURE RANGE	OUTSIDE NORTH AMERICA	NORTH AMERICA	DWG NUMBER
20-Pin Plastic SOL	-40°C to +85°C	74LVT273 D	74LVT273 D	SOT163-1
20-Pin Plastic SSOP Type II	-40°C to +85°C	74LVT273 DB	74LVT273 DB	SOT339-1
20-Pin Plastic TSSOP Type I	-40°C to +85°C	74LVT273 PW	74LVT273PW DH	SOT360-1

## PIN CONFIGURATION

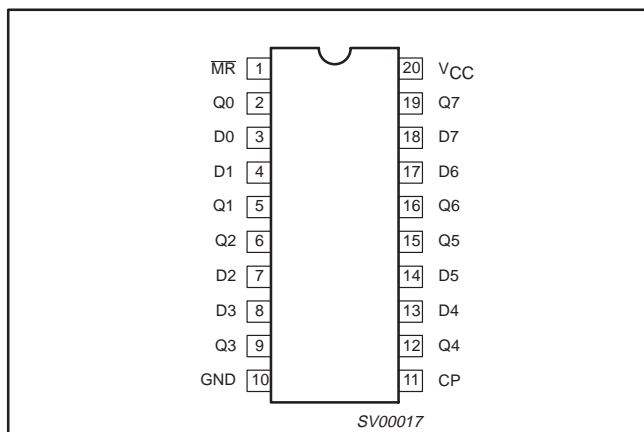

## LOGIC SYMBOL

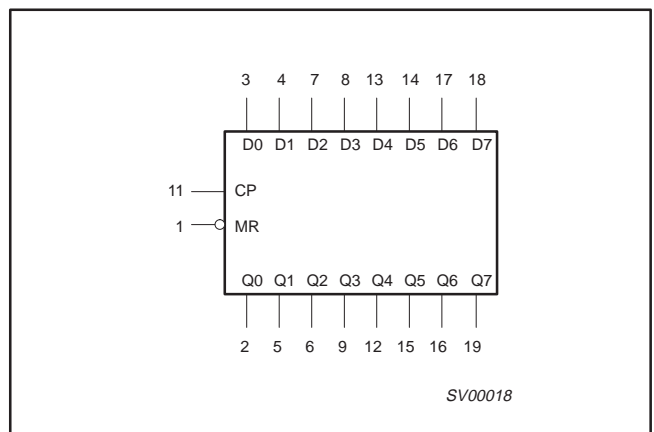

# 3.3V Octal D flip-flop

# 74LVT273

### LOGIC SYMBOL (IEEE/IEC)

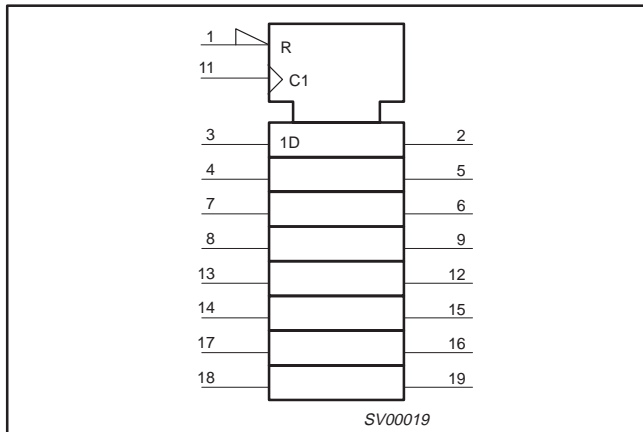

### FUNCTION TABLE

INPUTS			OUTPUTS	OPERATING MODE
MR	CP	D <sub>n</sub>	Q <sub>0</sub> – Q <sub>7</sub>	
L	X	X	L	Reset (clear)
H	↑	h	H	Load "1"
H	↑	l	L	Load "0"
H	L	X	Q <sub>0</sub>	Retain state

H = High voltage level  
 h = High voltage level one set-up time prior to the Low-to-High clock transition  
 L = Low voltage level  
 l = Low voltage level one set-up time prior to the Low-to-High clock transition  
 X = Don't care  
 ↑ = Low-to-High clock transition  
 Q<sub>0</sub> = Output as it was

### PIN DESCRIPTION

PIN NUMBER	SYMBOL	NAME AND FUNCTION
11	CP	Clock pulse input (active rising edge)
3, 4, 7, 8, 13, 14, 17, 18	D <sub>0</sub> – D <sub>7</sub>	Data inputs
2, 5, 6, 9, 12, 15, 16, 19	Q <sub>0</sub> – Q <sub>7</sub>	Data outputs
1	MR	Master Reset input (active-Low)
10	GND	Ground (0V)
20	V <sub>CC</sub>	Positive supply voltage

### LOGIC DIAGRAM

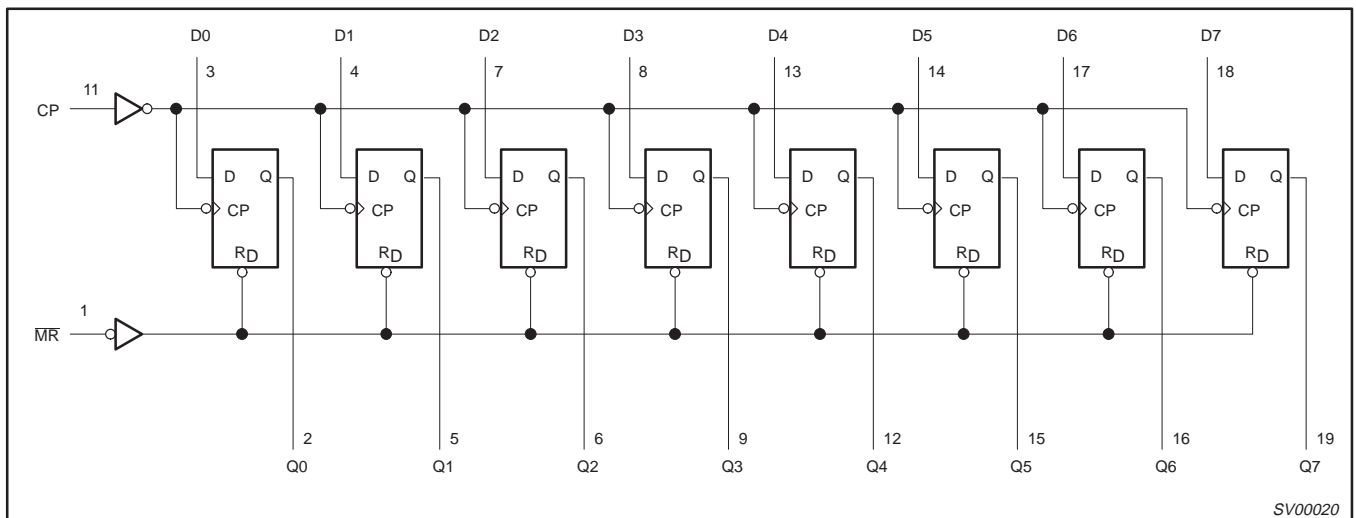

## 3.3V Octal D flip-flop

74LVT273

**ABSOLUTE MAXIMUM RATINGS<sup>1, 2</sup>**

SYMBOL	PARAMETER	CONDITIONS	RATING	UNIT
V <sub>CC</sub>	DC supply voltage		-0.5 to +4.6	V
I <sub>IK</sub>	DC input diode current	V <sub>I</sub> < 0	-50	mA
V <sub>I</sub>	DC input voltage <sup>3</sup>		-0.5 to +7.0	V
I <sub>OK</sub>	DC output diode current	V <sub>O</sub> < 0	-50	mA
V <sub>OUT</sub>	DC output voltage <sup>3</sup>	output in Off or High state	-0.5 to +7.0	V
I <sub>OUT</sub>	DC output current	Output in Low state	128	mA
		Output in High State	-64	
T <sub>stg</sub>	Storage temperature range		-65 to 150	°C

**NOTES:**

- Stresses beyond those listed may cause permanent damage to the device. These are stress ratings only and functional operation of the device at these or any other conditions beyond those indicated under "recommended operating conditions" is not implied. Exposure to absolute-maximum-rated conditions for extended periods may affect device reliability.
- The performance capability of a high-performance integrated circuit in conjunction with its thermal environment can create junction temperatures which are detrimental to reliability. The maximum junction temperature of this integrated circuit should not exceed 150°C.
- The input and output voltage ratings may be exceeded if the input and output current ratings are observed.

**RECOMMENDED OPERATING CONDITIONS**

SYMBOL	PARAMETER	LIMITS		UNIT
		MIN	MAX	
V <sub>CC</sub>	DC supply voltage	2.7	3.6	V
V <sub>I</sub>	Input voltage	0	5.5	V
V <sub>IH</sub>	High-level input voltage	2.0		V
V <sub>IL</sub>	Low-level Input voltage		0.8	V
I <sub>OH</sub>	High-level output current		-32	mA
I <sub>OL</sub>	Low-level output current		64	mA
Δt/Δv	Input transition rise or fall rate; Outputs enabled		10	ns/V
T <sub>amb</sub>	Operating free-air temperature range	-40	+85	°C

## 3.3V Octal D flip-flop

74LVT273

## DC ELECTRICAL CHARACTERISTICS

SYMBOL	PARAMETER	TEST CONDITIONS	LIMITS			UNIT
			Temp = -40°C to +85°C			
			MIN	TYP <sup>1</sup>	MAX	
V <sub>IK</sub>	Input clamp voltage	V <sub>CC</sub> = 2.7V; I <sub>IK</sub> = -18mA		-0.9	-1.2	V
V <sub>OH</sub>	High-level output voltage	V <sub>CC</sub> = 2.7 to 3.6V; I <sub>OH</sub> = -100μA	V <sub>CC</sub> -0.2	V <sub>CC</sub> -0.1		V
		V <sub>CC</sub> = 2.7V; I <sub>OH</sub> = -8mA	2.4	2.5		
		V <sub>CC</sub> = 3.0V; I <sub>OH</sub> = -32mA	2.0	2.2		
V <sub>OL</sub>	Low-level output voltage	V <sub>CC</sub> = 2.7V; I <sub>OL</sub> = 100μA		0.1	0.2	V
		V <sub>CC</sub> = 2.7V; I <sub>OL</sub> = 24mA		0.3	0.5	
		V <sub>CC</sub> = 3.0V; I <sub>OL</sub> = 16mA		0.25	0.4	
		V <sub>CC</sub> = 3.0V; I <sub>OL</sub> = 32mA		0.3	0.5	
		V <sub>CC</sub> = 3.0V; I <sub>OL</sub> = 64mA		0.4	0.55	
V <sub>RST</sub>	Power-up output low voltage <sup>4</sup>	V <sub>CC</sub> = 3.6V; I <sub>O</sub> = 1mA; V <sub>I</sub> = GND or V <sub>CC</sub>		0.13	0.55	V
I <sub>I</sub>	Input leakage current	V <sub>CC</sub> = 0 or 3.6V; V <sub>I</sub> = 5.5V		1	10	μA
		V <sub>CC</sub> = 3.6V; V <sub>I</sub> = V <sub>CC</sub> or GND	Control pins	±0.1	±1	
		V <sub>CC</sub> = 3.6V; V <sub>I</sub> = V <sub>CC</sub>	Data pins <sup>3</sup>	0.1	1	
		V <sub>CC</sub> = 3.6V; V <sub>I</sub> = 0		-1	-5	
I <sub>OFF</sub>	Output off current	V <sub>CC</sub> = 0V; V <sub>I</sub> or V <sub>O</sub> = 0 to 4.5V		1	±100	μA
I <sub>HOLD</sub>	Bus Hold current A inputs <sup>5</sup>	V <sub>CC</sub> = 3V; V <sub>I</sub> = 0.8V	75	150		μA
		V <sub>CC</sub> = 3V; V <sub>I</sub> = 2.0V	-75	-150		
		V <sub>CC</sub> = 0V to 3.6V; V <sub>CC</sub> = 3.6V	±500			
I <sub>EX</sub>	Current into an output in the High state when V <sub>O</sub> > V <sub>CC</sub>	V <sub>O</sub> = 5.5V; V <sub>CC</sub> = 3.0V		60	125	μA
I <sub>CCH</sub>	Quiescent supply current	V <sub>CC</sub> = 3.6V; Outputs High, V <sub>I</sub> = GND or V <sub>CC</sub> , I <sub>O</sub> = 0		0.13	0.19	mA
I <sub>CCL</sub>		V <sub>CC</sub> = 3.6V; Outputs Low, V <sub>I</sub> = GND or V <sub>CC</sub> , I <sub>O</sub> = 0		3	12	
ΔI <sub>CC</sub>	Additional supply current per input pin <sup>2</sup>	V <sub>CC</sub> = 3V to 3.6V; One input at V <sub>CC</sub> -0.6V, Other inputs at V <sub>CC</sub> or GND		0.1	0.2	mA

## NOTES:

- All typical values are at V<sub>CC</sub> = 3.3V and T<sub>amb</sub> = 25°C.
- This is the increase in supply current for each input at the specified voltage level other than V<sub>CC</sub> or GND
- Unused pins at V<sub>CC</sub> or GND.
- For valid test results, data must not be loaded into the flip-flops (or latches) after applying the power.
- This is the bus hold overdrive current required to force the input to the opposite logic state.

## AC CHARACTERISTICS

GND = 0V; t<sub>R</sub> = t<sub>F</sub> = 2.5ns; C<sub>L</sub> = 50pF, R<sub>L</sub> = 500Ω; T<sub>amb</sub> = -40°C to +85°C.

SYMBOL	PARAMETER	WAVEFORM	LIMITS				UNIT
			V <sub>CC</sub> = 3.3V ±0.3V			V <sub>CC</sub> = 2.7V	
			MIN	TYP <sup>1</sup>	MAX	MAX	
f <sub>MAX</sub>	Maximum clock frequency	1	150				MHz
t <sub>PLH</sub> t <sub>PHL</sub>	Propagation delay CP to Qn	1	1.7	3.5	5.5	6.3	ns
			1.9	3.5	5.5	5.9	
t <sub>PHL</sub>	Propagation delay MR to Qn	2	1.3	3.2	6.2	6.2	ns

## NOTE:

- All typical values are at V<sub>CC</sub> = 3.3V and T<sub>amb</sub> = 25°C.

# 3.3V Octal D flip-flop

74LVT273

## AC SETUP REQUIREMENTS

GND = 0V;  $t_R = t_F = 2.5\text{ns}$ ;  $C_L = 50\text{pF}$ ,  $R_L = 500\Omega$ ,  $T_{\text{amb}} = -40^\circ\text{C}$  to  $+85^\circ\text{C}$ .

SYMBOL	PARAMETER	WAVEFORM	LIMITS			UNIT
			$V_{CC} = +3.3 \pm 0.3\text{V}$		$V_{CC} = 2.7\text{V}$	
			MIN	TYP	MIN	
$t_{s(H)}$ $t_{s(L)}$	Setup time, High or Low Dn to CP	3	2.3 2.3	1.0 1.0	2.7 2.7	ns
$t_{h(H)}$ $t_{h(L)}$	Hold time, High or Low Dn to CP	3	0 0	-0.6 -0.6	0 0	ns
$t_{w(H)}$ $t_{w(L)}$	Clock pulse width High or Low	1	3.3 3.3	1.5 1.5	3.3 3.3	ns
$t_{w(L)}$	Master Reset pulse width, Low	2	3.3	1.5	3.3	ns
$t_{\text{REC}}$	Recovery time MR to CP	2	2.7	1.0	3.2	ns

## AC WAVEFORMS

$V_M = 1.5\text{V}$ ,  $V_{\text{IN}} = \text{GND to } 2.7\text{V}$

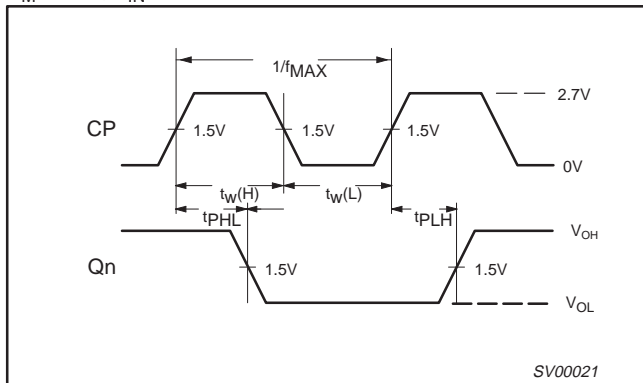

**Waveform 1. Propagation Delay, Clock Input to Output, Clock Pulse Width, and Maximum Clock Frequency**

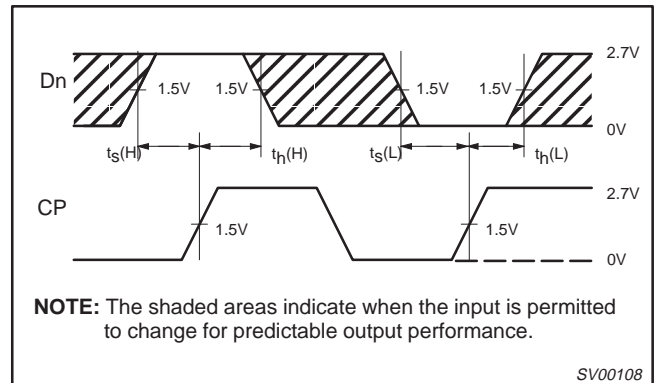

**NOTE:** The shaded areas indicate when the input is permitted to change for predictable output performance.

**Waveform 3. Data Setup and Hold Times**

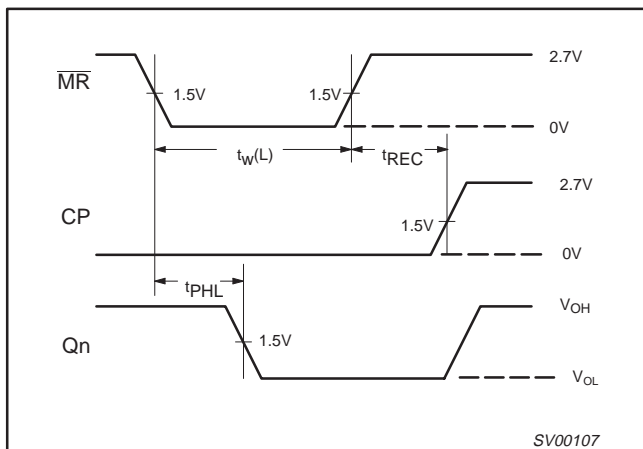

**Waveform 2. Master Reset Pulse Width, Master Reset to Output Delay and Master Reset to Clock Recovery Time**

# 3.3V Octal D flip-flop

# 74LVT273

## TEST CIRCUIT AND WAVEFORMS

Test Circuit for Outputs

$V_M = 1.5V$   
Input Pulse Definition

**DEFINITIONS**

$R_L$  = Load resistor; see AC CHARACTERISTICS for value.

$C_L$  = Load capacitance includes jig and probe capacitance; see AC CHARACTERISTICS for value.

$R_T$  = Termination resistance should be equal to  $Z_{OUT}$  of pulse generators.

SV00022

FAMILY	INPUT PULSE REQUIREMENTS				
	Amplitude	Rep. Rate	$t_w$	$t_r$	$t_f$
74LVT	2.7V	$\leq 10\text{MHz}$	500ns	$\leq 2.5\text{ns}$	$\leq 2.5\text{ns}$

# 3.3V Octal D flip-flop

# 74LVT273

**SO20:** plastic small outline package; 20 leads; body width 7.5 mm

**SOT163-1**

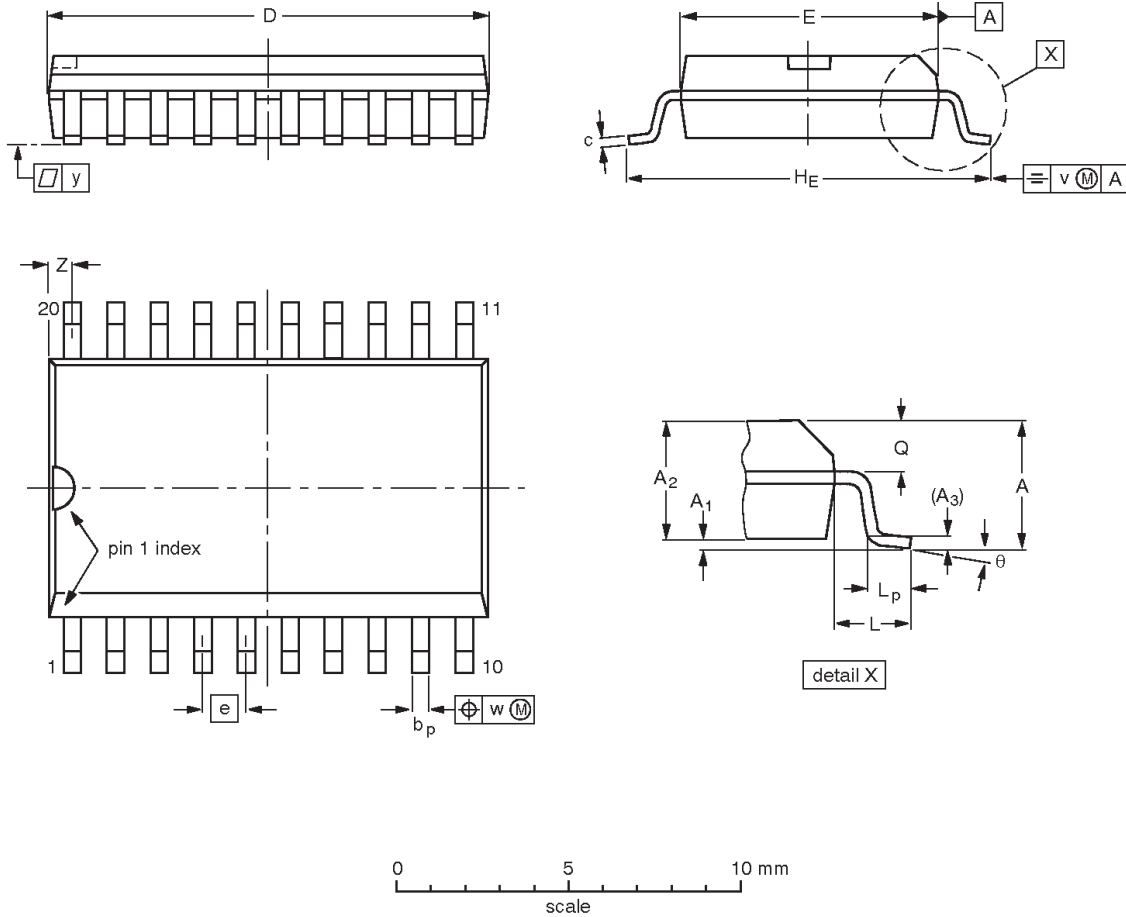

**DIMENSIONS (inch dimensions are derived from the original mm dimensions)**

UNIT	A max.	A <sub>1</sub>	A <sub>2</sub>	A <sub>3</sub>	b <sub>p</sub>	c	D <sup>(1)</sup>	E <sup>(1)</sup>	e	HE	L	L <sub>p</sub>	Q	v	w	y	z <sup>(1)</sup>	θ
mm	2.65	0.30 0.10	2.45 2.25	0.25	0.49 0.36	0.32 0.23	13.0 12.6	7.6 7.4	1.27	10.65 10.00	1.4	1.1 0.4	1.1 1.0	0.25	0.25	0.1	0.9 0.4	8° 0°
inches	0.10	0.012 0.004	0.096 0.089	0.01	0.019 0.014	0.013 0.009	0.51 0.49	0.30 0.29	0.050	0.419 0.394	0.055	0.043 0.016	0.043 0.039	0.01	0.01	0.004	0.035 0.016	

**Note**

1. Plastic or metal protrusions of 0.15 mm maximum per side are not included.

OUTLINE VERSION	REFERENCES				EUROPEAN PROJECTION	ISSUE DATE
	IEC	JEDEC	EIAJ			
SOT163-1	075E04	MS-013AC				95-01-24 97-05-22

# 3.3V Octal D flip-flop

# 74LVT273

**SSOP20:** plastic shrink small outline package; 20 leads; body width 5.3 mm

**SOT339-1**

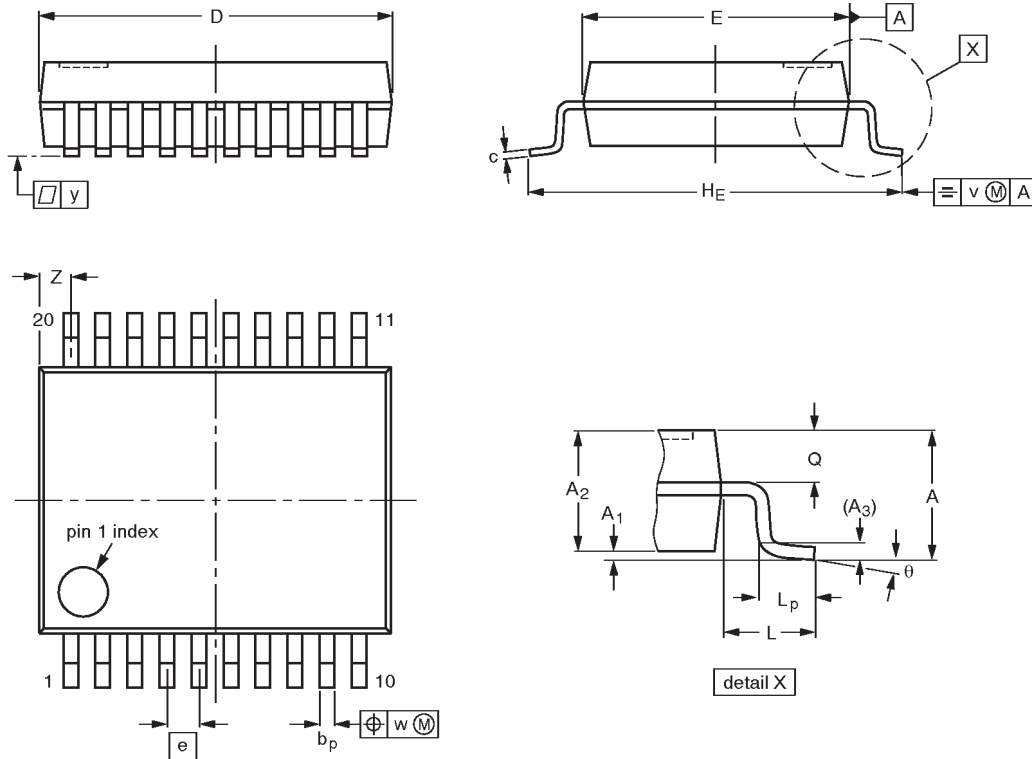

**DIMENSIONS (mm are the original dimensions)**

UNIT	A max.	A <sub>1</sub>	A <sub>2</sub>	A <sub>3</sub>	b <sub>p</sub>	c	D <sup>(1)</sup>	E <sup>(1)</sup>	e	H <sub>E</sub>	L	L <sub>p</sub>	Q	v	w	y	Z <sup>(1)</sup>	θ
mm	2.0	0.21 0.05	1.80 1.65	0.25	0.38 0.25	0.20 0.09	7.4 7.0	5.4 5.2	0.65	7.9 7.6	1.25	1.03 0.63	0.9 0.7	0.2	0.13	0.1	0.9 0.5	8° 0°

**Note**

1. Plastic or metal protrusions of 0.20 mm maximum per side are not included.

OUTLINE VERSION	REFERENCES				EUROPEAN PROJECTION	ISSUE DATE
	IEC	JEDEC	EIAJ			
SOT339-1		MO-150AE				93-09-08 95-02-04

# 3.3V Octal D flip-flop

# 74LVT273

**TSSOP20:** plastic thin shrink small outline package; 20 leads; body width 4.4 mm

**SOT360-1**

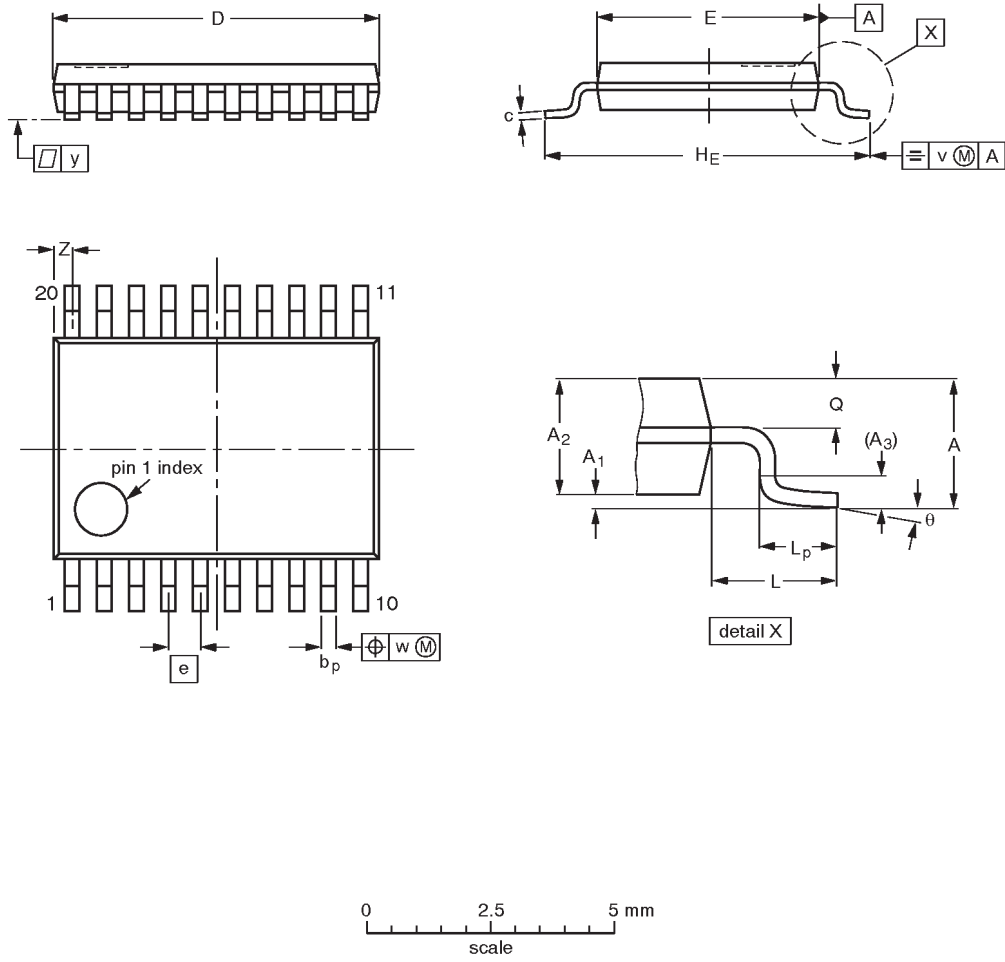

**DIMENSIONS (mm are the original dimensions)**

UNIT	A max.	A <sub>1</sub>	A <sub>2</sub>	A <sub>3</sub>	b <sub>p</sub>	c	D <sup>(1)</sup>	E <sup>(2)</sup>	e	H <sub>E</sub>	L	L <sub>p</sub>	Q	v	w	y	Z <sup>(1)</sup>	θ
mm	1.10	0.15 0.05	0.95 0.80	0.25	0.30 0.19	0.2 0.1	6.6 6.4	4.5 4.3	0.65	6.6 6.2	1.0	0.75 0.50	0.4 0.3	0.2	0.13	0.1	0.5 0.2	8° 0°

**Notes**

1. Plastic or metal protrusions of 0.15 mm maximum per side are not included.
2. Plastic interlead protrusions of 0.25 mm maximum per side are not included.

OUTLINE VERSION	REFERENCES				EUROPEAN PROJECTION	ISSUE DATE
	IEC	JEDEC	EIAJ			
SOT360-1		MO-153AC				93-06-16 95-02-04

## 3.3V Octal D flip-flop

74LVT273

## Data sheet status

Data sheet status	Product status	Definition [1]
Objective specification	Development	This data sheet contains the design target or goal specifications for product development. Specification may change in any manner without notice.
Preliminary specification	Qualification	This data sheet contains preliminary data, and supplementary data will be published at a later date. Philips Semiconductors reserves the right to make changes at any time without notice in order to improve design and supply the best possible product.
Product specification	Production	This data sheet contains final specifications. Philips Semiconductors reserves the right to make changes at any time without notice in order to improve design and supply the best possible product.

[1] Please consult the most recently issued datasheet before initiating or completing a design.

## Definitions

**Short-form specification** — The data in a short-form specification is extracted from a full data sheet with the same type number and title. For detailed information see the relevant data sheet or data handbook.

**Limiting values definition** — Limiting values given are in accordance with the Absolute Maximum Rating System (IEC 134). Stress above one or more of the limiting values may cause permanent damage to the device. These are stress ratings only and operation of the device at these or at any other conditions above those given in the Characteristics sections of the specification is not implied. Exposure to limiting values for extended periods may affect device reliability.

**Application information** — Applications that are described herein for any of these products are for illustrative purposes only. Philips Semiconductors make no representation or warranty that such applications will be suitable for the specified use without further testing or modification.

## Disclaimers

**Life support** — These products are not designed for use in life support appliances, devices or systems where malfunction of these products can reasonably be expected to result in personal injury. Philips Semiconductors customers using or selling these products for use in such applications do so at their own risk and agree to fully indemnify Philips Semiconductors for any damages resulting from such application.

**Right to make changes** — Philips Semiconductors reserves the right to make changes, without notice, in the products, including circuits, standard cells, and/or software, described or contained herein in order to improve design and/or performance. Philips Semiconductors assumes no responsibility or liability for the use of any of these products, conveys no license or title under any patent, copyright, or mask work right to these products, and makes no representations or warranties that these products are free from patent, copyright, or mask work right infringement, unless otherwise specified.

Philips Semiconductors  
811 East Arques Avenue  
P.O. Box 3409  
Sunnyvale, California 94088-3409  
Telephone 800-234-7381

© Copyright Philips Electronics North America Corporation 1998  
All rights reserved. Printed in U.S.A.

print code

Date of release: 05-96

Document order number:

9397-750-03534

*Let's make things better.*



LittleDiode supplies new, hard to find or obsolete electronic components and semiconductors all over the world.

With over two million different components listed you are sure to find the part you need.

Feel free to visit us today at our online store:

[LittleDiode.com](http://LittleDiode.com)

Looking forward to providing you with the best possible service.