

DUAL FULL-BRIDGE PWM MOTOR DRIVER

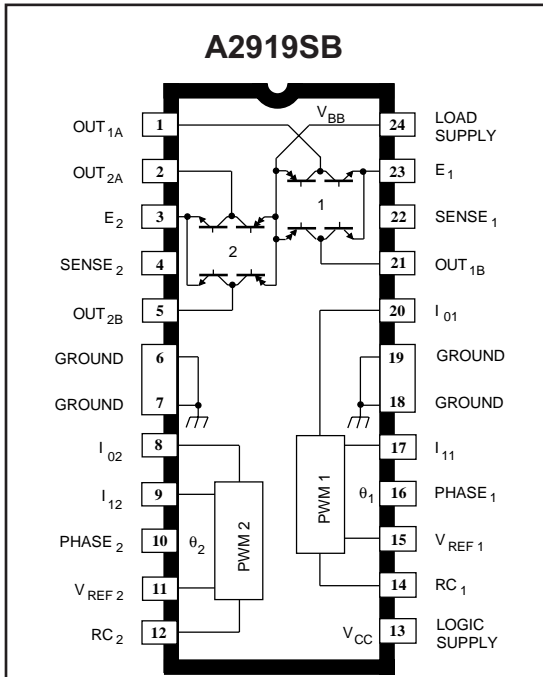

Dwg. PP-005

ABSOLUTE MAXIMUM RATINGS at $T_J \leq 150^\circ\text{C}$

- Motor Supply Voltage, V_{BB} **45 V**
- Output Current, I_{OUT}
(Peak, $t_w \leq 20 \mu\text{s}$) **$\pm 1.0 \text{ A}$**
(Continuous) **$\pm 750 \text{ mA}$**
- Logic Supply Voltage, V_{CC} **7.0 V**
- Logic Input Voltage Range,
 V_{IN} **-0.3 V to +7.0 V**
- Output Emitter Voltage, V_E **1.5 V**
- Package Power Dissipation,
 P_D **See Graph**
- Operating Temperature Range,
 T_A **-20°C to $+85^\circ\text{C}$**
- Storage Temperature Range,
 T_S **-55°C to $+150^\circ\text{C}$**

Output current rating may be limited by duty cycle, ambient temperature, and heat sinking. Under any set of conditions, do not exceed the specified peak current rating or a junction temperature of $+150^\circ\text{C}$.

The A2919SB and A2919SLB motor drivers are designed to drive both windings of a bipolar stepper motor or bidirectionally control two dc motors. Both bridges are capable of sustaining 45 V and include internal pulse-width modulation (PWM) control of the output current to 750 mA. The outputs have been optimized for a low output-saturation voltage drop (less than 1.8 V total source plus sink at 500 mA).

For PWM current control, the maximum output current is determined by the user's selection of a reference voltage and sensing resistor. Two logic-level inputs select output current limits of 0%, 41%, 67%, or 100% of the maximum level. A PHASE input to each bridge determines load current direction.

The bridges include both ground clamp and flyback diodes for protection against inductive transients. Internally generated delays prevent cross-over currents when switching current direction. Special power-up sequencing is not required. Thermal protection circuitry disables the outputs if the chip temperature exceeds safe operating limits.

The A2919SB is supplied in a 24-pin dual in-line plastic batwing package with a copper lead-frame and heat sinkable tabs for improved power dissipation capabilities. The A2919SLB is supplied in a 24-lead surface-mountable SOIC. Their batwing construction provides for maximum package power dissipation in the smallest possible construction. The A2919SB/SLB are available for operation from -40°C to $+85^\circ\text{C}$. To order, change the suffix from 'S-' to 'E-'. These devices are also available on special order for operation to $+125^\circ\text{C}$. For applications not requiring quarter-step operation, but desire lower detent or running current, the similar UDN2916B/EB/LB may be preferred.

FEATURES

- 750 mA Continuous Output Current
- 45 V Output Sustaining Voltage
- Internal Clamp Diodes
- Internal PWM Current Control
- Low Output Saturation Voltage
- Internal Thermal Shutdown Circuitry
- Half- or Quarter-Step Operation of Bipolar Stepper Motors

Always order by complete part number:

Part Number	Package	$R_{\theta JA}$	$R_{\theta JT}$
A2919SB	24-Pin DIP	40°C/W	6.0°C/W
A2919SLB	24-Lead SOIC	55°C/W	6.0°C/W

2919 DUAL FULL-BRIDGE MOTOR DRIVER

A2919SLB

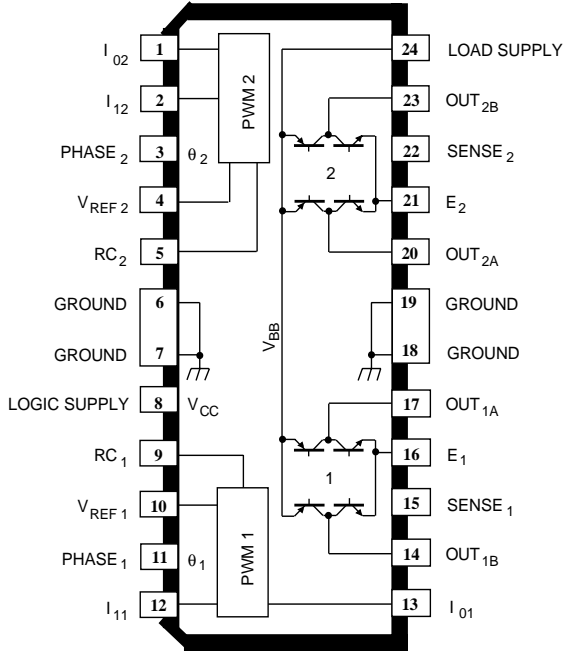

Dwg. PP-047

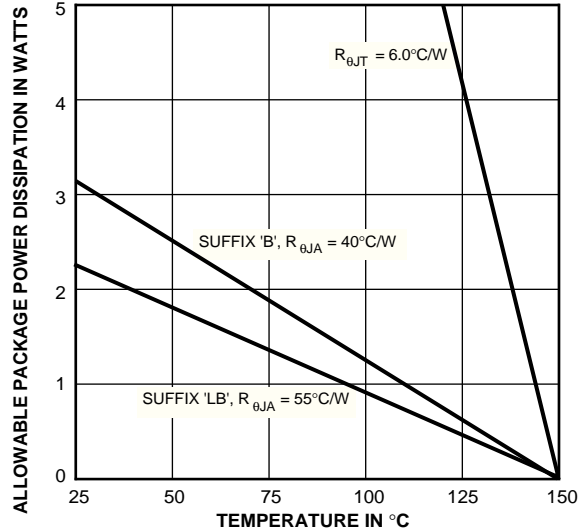

Dwg. GP-049A

TRUTH TABLE

PHASE	OUT _A	OUT _B
H	H	L
L	L	H

PWM CURRENT-CONTROL CIRCUITRY

'B' PACKAGE,
CHANNEL 1
PIN NUMBERS
SHOWN.

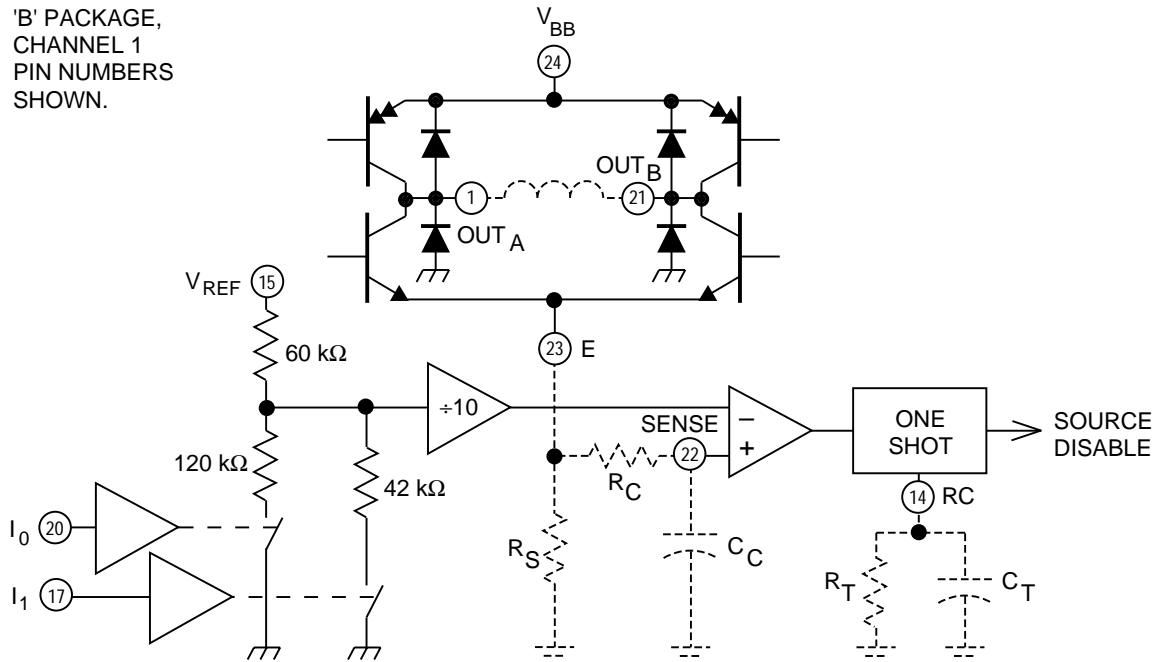

Dwg. EP-007-3

2919

DUAL FULL-BRIDGE MOTOR DRIVER

ELECTRICAL CHARACTERISTICS at $T_A = +25^\circ\text{C}$, $T_J \leq 150^\circ\text{C}$, $V_{BB} = 45\text{ V}$, $V_{CC} = 4.75\text{ V to } 5.25\text{ V}$, $V_{REF} = 5.0\text{ V}$ (unless otherwise noted).

Characteristic	Symbol	Test Conditions	Limits			
			Min.	Typ.	Max.	Units

Output Drivers (OUT_A or OUT_B)

Motor Supply Range	V_{BB}	Operating	10	—	45	V
Output Leakage Current	I_{CEX}	$V_{OUT} = V_{BB}$	—	< 1.0	50	μA
		$V_{OUT} = 0$	—	<-1.0	-50	μA
Output Sustaining Voltage	$V_{CE(sus)}$	$I_{OUT} = \pm 750\text{ mA}$, $L = 3.0\text{ mH}$	$45 + V_F$	—	—	V
Output Saturation Voltage	$V_{CE(SAT)}$	Sink Driver, $I_{OUT} = +500\text{ mA}$	—	0.4	0.6	V
		Sink Driver, $I_{OUT} = +750\text{ mA}$	—	1.0	1.2	V
		Source Driver, $I_{OUT} = -500\text{ mA}$	—	1.0	1.2	V
		Source Driver, $I_{OUT} = -750\text{ mA}$	—	1.3	1.5	V
Clamp Diode Leakage Current	I_R	$V_R = 45\text{ V}$	—	< 1.0	50	μA
Clamp Diode Forward Voltage	V_F	$I_F = 750\text{ mA}$	—	1.6	2.0	V
Driver Supply Current	$I_{BB(ON)}$	Both Bridges ON, No Load	—	20	25	mA
	$I_{BB(OFF)}$	Both Bridges OFF	—	5.0	10	mA

Control Logic

Input Voltage	$V_{IN(1)}$	All inputs	2.4	—	—	V
	$V_{IN(0)}$	All inputs	—	—	0.8	V
Input Current	$I_{IN(1)}$	$V_{IN} = 2.4\text{ V}$	—	<1.0	20	μA
		$V_{IN} = 0.8\text{ V}$	—	-3.0	-200	μA
Reference Voltage Range	V_{REF}		1.0	—	7.5	V
Current Limit Threshold (at trip point)	V_{REF}/V_{SENSE}	$I_0 = I_1 = 0.8\text{ V}$, $V_{REF} = 1.0\text{ V to } 7.5\text{ V}$	9.5	10	10.5	—
		$I_0 = 2.4\text{ V}$, $I_1 = 0.8\text{ V}$, $V_{REF} = 1.5\text{ V to } 7.5\text{ V}$	13.5	15	16.5	—
		$I_0 = 0.8\text{ V}$, $I_1 = 2.4\text{ V}$, $V_{REF} = 1.5\text{ V to } 7.5\text{ V}$	20.7	24.4	28.0	—
Thermal Shutdown Temperature	T_J		—	170	—	$^\circ\text{C}$
Total Logic Supply Current	$I_{CC(ON)}$	$I_0 = I_1 = 0.8\text{ V}$, No Load	—	40	50	mA
	$I_{CC(OFF)}$	$I_0 = I_1 = 2.4\text{ V}$, No Load	—	10	12	mA
Total Reference Current	$I_{REF1} + I_{REF2}$	$V_{REF1} = V_{REF2} = 7.5\text{ V}$, $I_0 = I_1 = 2.4\text{ V}$	140	185	250	μA

2919 DUAL FULL-BRIDGE MOTOR DRIVER

APPLICATIONS INFORMATION

PWM CURRENT CONTROL

The A2919SB/SLB dual bridges are designed to drive both windings of a bipolar stepper motor. Output current is sensed and controlled independently in each bridge by an external sense resistor (R_S), internal comparator, and monostable multivibrator.

When the bridge is turned ON, current increases in the motor winding and flows through the external sense resistor until the sense voltage (V_S) reaches the level set at the comparator's input:

$$I_{TRIP} = V_{REF} / 10 R_S$$

The comparator then triggers the monostable, which turns OFF the source driver of the bridge. The actual load current peak will be slightly higher than the trip point (especially for low-inductance loads) because of the internal logic and switching delays. This delay (t_d) is typically 2 μ s. After turn-off, the motor current decays, circulating through the ground-clamp diode and sink transistor. The source driver's OFF time (and therefore the magnitude of the current decrease) is determined by the monostable's external RC timing components, where $t_{off} = R_T C_T$ within the range of 20 k Ω to 100 k Ω and 100 pF to 1000 pF.

When the source driver is re-enabled, the winding current (the sense voltage) is again allowed to rise to the comparator's threshold. This cycle repeats itself, maintaining the average motor winding current at the desired level.

Loads with high distributed capacitances may cause current spikes capable of tripping the comparator, resulting in erroneous current control. An external $R_C C_C$ time delay should be used to delay the action of the comparator. Depending on load type, many applications will not require these external components (SENSE connected to E).

PWM OUTPUT CURRENT WAVE FORM

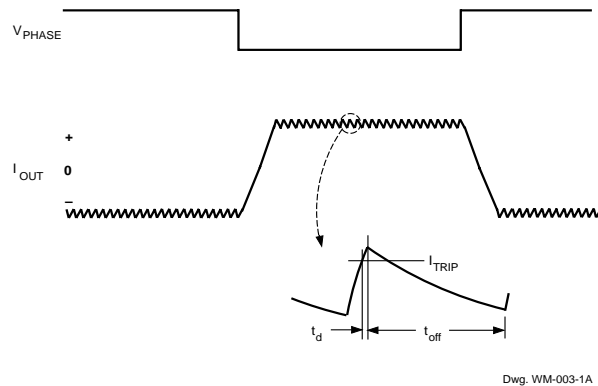

LOAD CURRENT PATHS

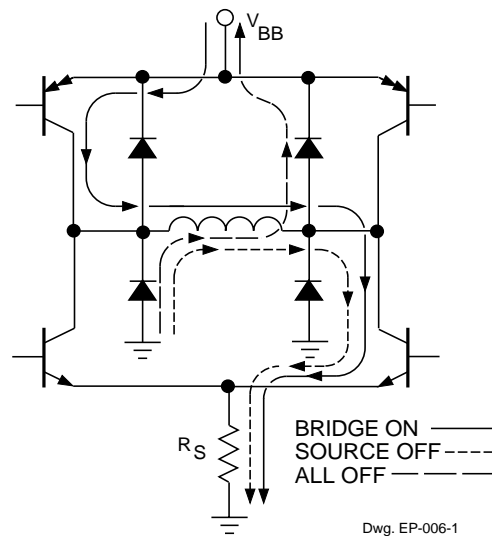

2919

DUAL FULL-BRIDGE MOTOR DRIVER

LOGIC CONTROL OF OUTPUT CURRENT

Two logic level inputs (I_0 and I_1) allow digital selection of the motor winding current at 100%, 67%, 41%, or 0% of the maximum level per the table. The 0% output current condition turns OFF all drivers in the bridge and can be used as an OUTPUT ENABLE function.

CURRENT-CONTROL TRUTH TABLE

I_0	I_1	Output Current
L	L	$V_{REF}/10 R_S = 100\% I_{TRIP}$
H	L	$V_{REF}/15 R_S = 67\% I_{TRIP}$
L	H	$V_{REF}/24.4 R_S = 41\% I_{TRIP}$
H	H	0

These logic level inputs greatly enhance the implementation of μ P-controlled drive formats.

During half-step operations, I_0 and I_1 allow the μ P to control the motor at a constant torque between all positions in an eight-step sequence. This is accomplished by digitally selecting 100% drive current when only one phase is ON and 67% drive current when two phases are ON. Logic highs on both I_0 and I_1 turn OFF all drivers to allow rapid current decay.

During quarter-step operation, I_0 and I_1 allow the μ P to control the motor position in a sixteen-step sequence. This is accomplished by digitally selecting drive current as shown in the table (for one quadrant of operation). Logic highs on both I_0 and I_1 turn OFF all drivers to allow rapid current decay.

The logic control inputs can also be used to select a reduced current level (and reduced power dissipation) for 'hold' conditions and/or increased current (and available torque) for start-up conditions.

QUARTER-STEPPING CURRENT CONTROL

Phase 1 Current Level	Phase 2 Current Level
100%	0%
100%	41%
67%	67%
41%	100%
0%	100%

GENERAL

The PHASE input to each bridge determines the direction motor winding current flows. An internally generated deadtime (approximately 2 μ s) prevents cross-over currents that can occur when switching the PHASE input.

All four drivers in the bridge output can be turned OFF between steps ($I_0 = I_1 \geq 2.4$ V) resulting in a fast current decay through the internal output clamp and flyback diodes. The fast current decay is desirable in half-step and high-speed applications. The PHASE, I_0 , and I_1 inputs float high.

Varying the reference voltage (V_{REF}) provides continuous control of the peak load current for micro-stepping applications.

Thermal protection circuitry turns OFF all drivers when the junction temperature reaches +170°C. It is only intended to protect the device from failures due to excessive junction temperature and should not imply that output short circuits are permitted. The output drivers are re-enabled when the junction temperature cools to +145°C.

The A2919SB/SLB output drivers are optimized for low output saturation voltages—less than 1.8 V total (source plus sink) at 500 mA. Under normal operating conditions, when combined with the excellent thermal properties of the batwing package design, this allows continuous operation of both bridges simultaneously at 500 mA.

2919 DUAL FULL-BRIDGE MOTOR DRIVER

TYPICAL APPLICATION

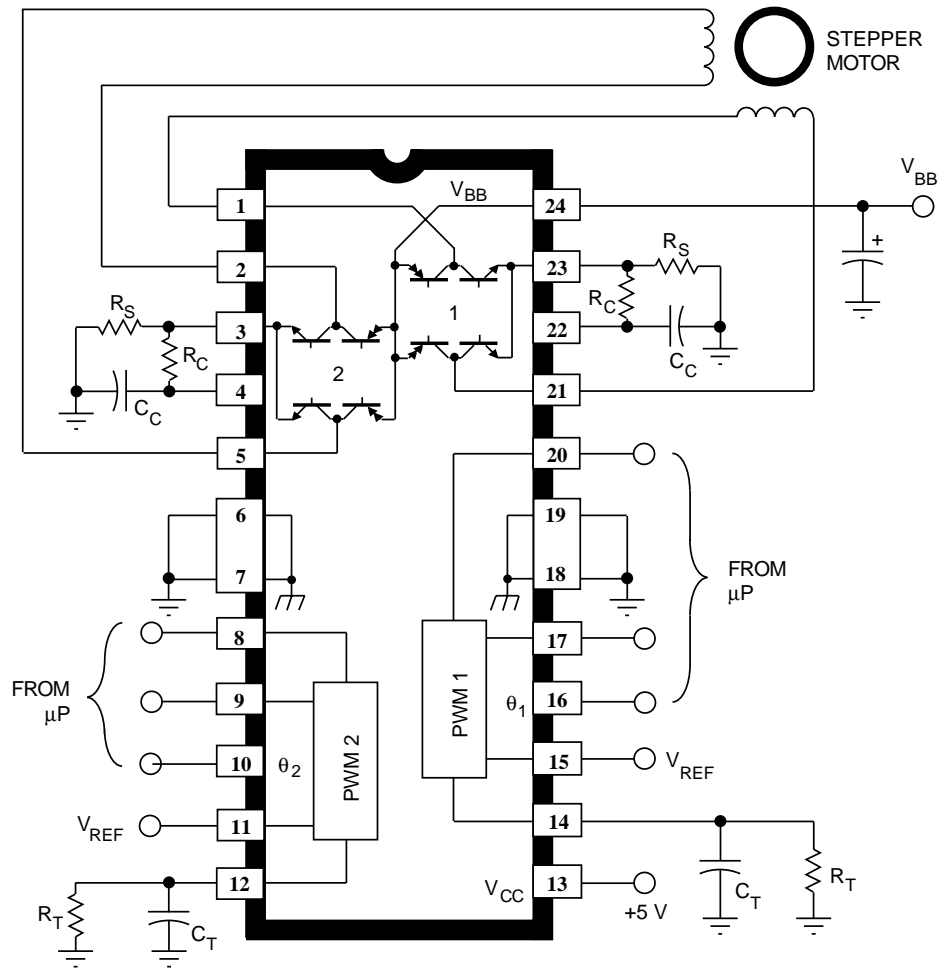

Dwg. EP-008B

2919 DUAL FULL-BRIDGE MOTOR DRIVER

A2919SB

Dimensions in Inches
(controlling dimensions)

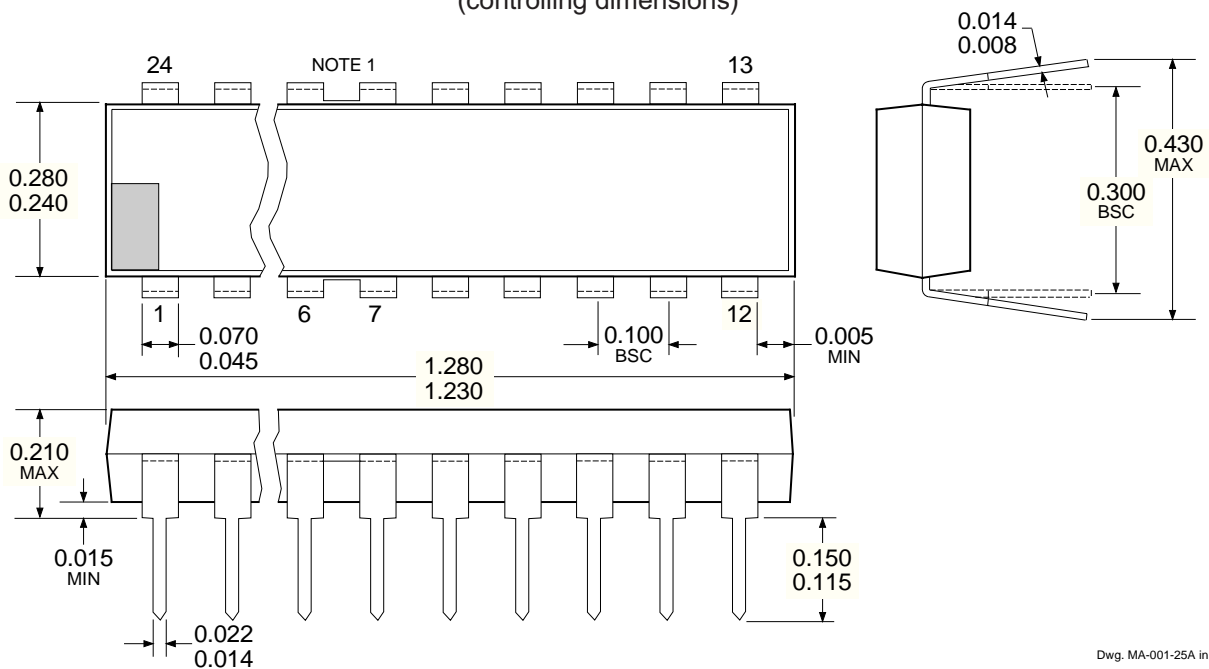

Dimensions in Millimeters
(for reference only)

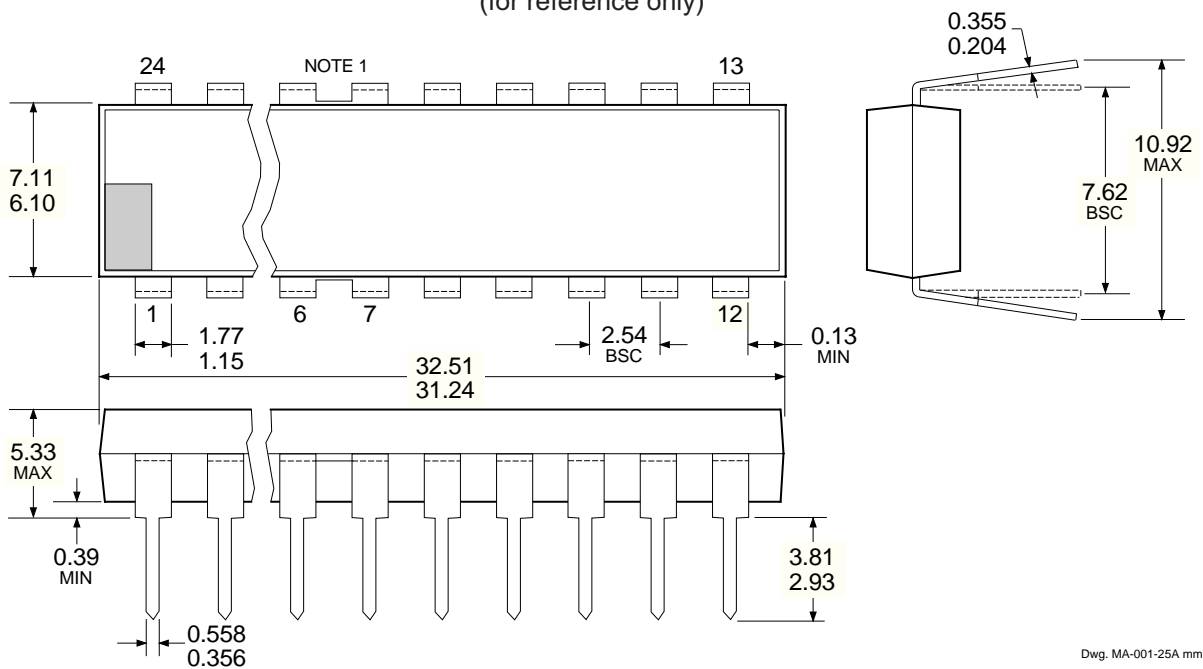

- NOTES:
1. Webbed lead frame. Leads 6, 7, 18, and 19 are internally one piece.
 2. Lead thickness is measured at seating plane or below.
 3. Lead spacing tolerance is non-cumulative.
 4. Exact body and lead configuration at vendor's option within limits shown.

2919 DUAL FULL-BRIDGE MOTOR DRIVER

A2919SLB Dimensions in Inches (for reference only)

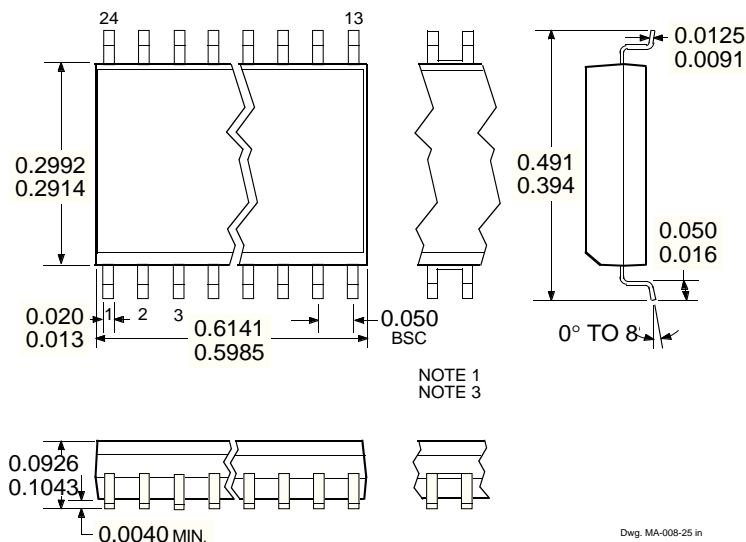

Dimensions in Millimeters (controlling dimensions)

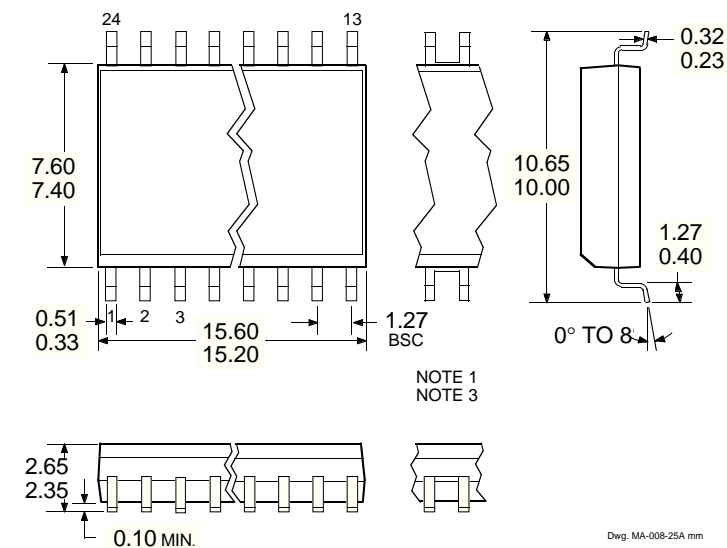

Allegro MicroSystems, Inc. reserves the right to make, from time to time, such departures from the detail specifications as may be required to permit improvements in the design of its products.

The information included herein is believed to be accurate and reliable. However, Allegro MicroSystems, Inc. assumes no responsibility for its use; nor for any infringements of patents or other rights of third parties which may result from its use.

- NOTES:
1. Webbed lead frame. Leads 6, 7, 18, and 19 are internally one piece.
 2. Lead spacing tolerance is non-cumulative.
 3. Exact body and lead configuration at vendor's option within limits shown.



LittleDiode supplies new, hard to find or obsolete electronic components and semiconductors all over the world.

With over two million different components listed you are sure to find the part you need.

Feel free to visit us today at our online store:

LittleDiode.com

Looking forward to providing you with the best possible service.