

# 3064

## HALL-EFFECT GEAR-TOOTH SENSOR —AC COUPLED

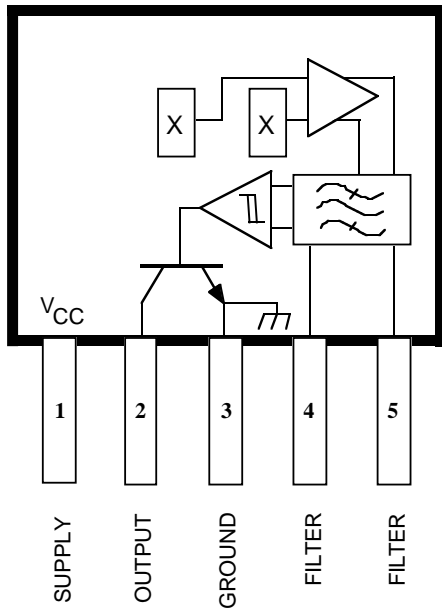

Dwg. PH-011-1

Pinning is shown viewed from branded side.

### ABSOLUTE MAXIMUM RATINGS at $T_A = +25^\circ\text{C}$

|   |   |
|---|---|
| Supply Voltage, $V_{CC}$ .....              | 24 V  |
| Reverse Battery Voltage, $V_{RCC}$ .....    | -30 V                                       |
| Magnetic Flux Density, $B$ .....            | Unlimited                                   |
| Output Off Voltage, $V_{OUT}$ .....         | 24 V  |
| Output Current, $I_{OUT}$ .....             | 25 mA                                       |
| Package Power Dissipation,<br>$P_D$ .....   | 500 mW                                      |
| Operating Temperature Range,<br>$T_A$ ..... | $-40^\circ\text{C}$ to $+150^\circ\text{C}$ |
| Storage Temperature Range,<br>$T_S$ .....   | $-65^\circ\text{C}$ to $+170^\circ\text{C}$ |

The A3064LKA ac-coupled Hall-effect gear-tooth sensor is a monolithic integrated circuit that switches in response to changing differential magnetic fields created by moving ferrous targets. This device is ideal for use in non-zero-speed, gear-tooth-based speed, position, and timing applications such as in anti-lock braking systems, transmissions, and crankshafts.

When coupled with a back-biasing magnet, the sensor can be configured to turn on or off with the leading or trailing edge of a gear-tooth or slot. Changes in fields on the magnet face caused by a moving ferrous mass are sensed by two integrated Hall transducers and are differentially amplified by on-chip electronics. This differential sensing design provides immunity to radial vibration within the device's operating air gap. Steady-state magnet and system offsets are eliminated using an on-chip differential band-pass filter. This filter also provides relative immunity to interference from RF and electromagnetic sources. The on-chip temperature compensation and Schmitt trigger circuitry minimizes shifts in effective working air gaps and switch points over temperature, allowing operation to low frequencies over a wide range of air gaps and temperatures.

Each Hall-effect digital Integrated circuit includes a voltage regulator, two quadratic Hall-effect sensing elements, temperature compensating circuitry, a low-level amplifier, band-pass filter, Schmitt trigger, and an open-collector output driver. The on-board regulator permits operation with supply voltages of 4.5 to 24 volts. The output stage can easily switch 20 mA over the full frequency response range of the sensor and is compatible with bipolar and MOS logic circuits.

The device is packaged in a 5-pin plastic SIP.

### FEATURES

- Senses Motion of Ferrous Targets
- Wide Operating Temperature Range
- Operation to 30 kHz
- Resistant to EMI
- Large Effective Air Gap
- 4.5 V to 24 V Operation
- Output Compatible With All Logic Families
- Reverse Battery Protection
- Resistant to Physical Stress

Always order by complete part number, e.g., **A3064LKA**.

# 3064 HALL-EFFECT GEAR-TOOTH SENSOR —AC COUPLED

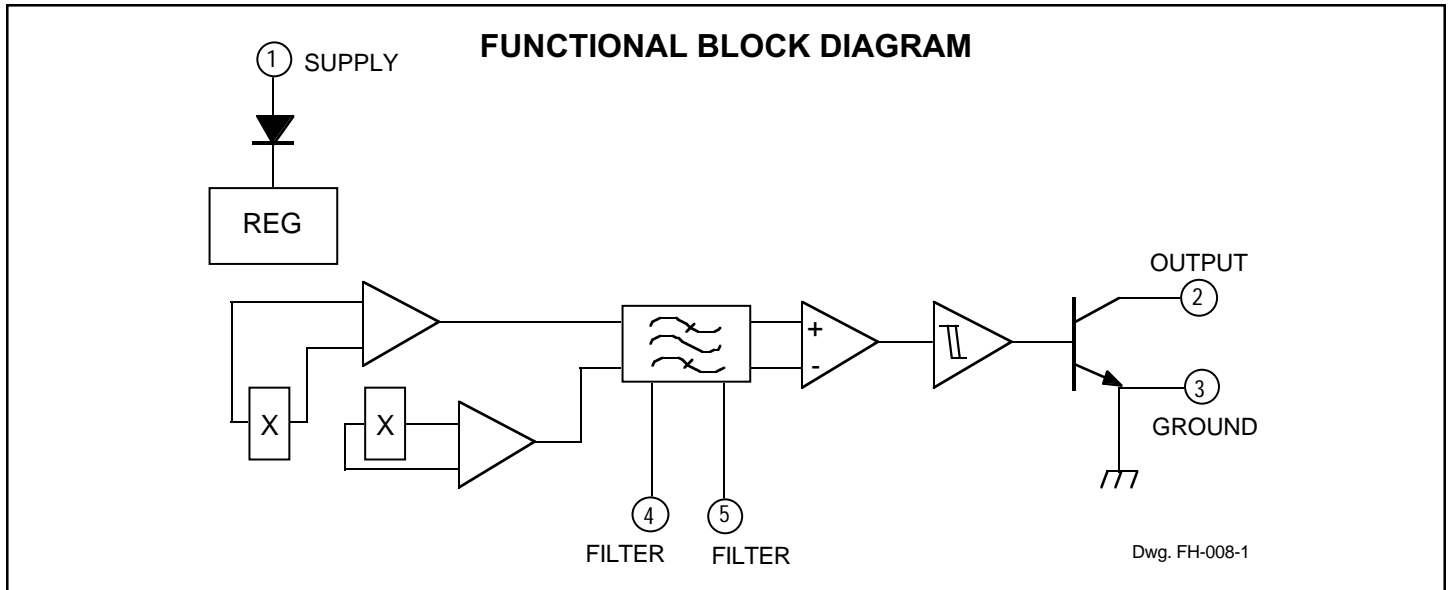

## ELECTRICAL CHARACTERISTICS over operating temperature and supply voltage range.

| Characteristic            | Symbol         | Test Conditions                               | Limits |      |      | Units         |
|---------------------------|----------------|---|--------|------|------|---------------|
|                           |                |   | Min.   | Typ. | Max. |               |
| Supply Voltage            | $V_{CC}$       | Operating                                     | 4.5    | —    | 24   | V             |
| Output Saturation Voltage | $V_{OUT(SAT)}$ | $I_{OUT} = 18 \text{ mA}$ , $B < B_{RP}$      | —      | 141  | 400  | mV            |
| Output Leakage Current    | $I_{OFF}$      | $V_{OUT} = 24 \text{ V}$ , $B > B_{OP}$       | —      | —    | 5.0  | $\mu\text{A}$ |
| Supply Current            | $I_{CC}$       | $B < B_{RP}$                                  | —      | 11   | 20   | mA            |
|                           |                | $B > B_{OP}$                                  | —      | 9.6  | —    | mA            |
| High-Frequency Cutoff     | $f_{coh}$      | -3 dB   | 30     | —    | —    | kHz           |
| Output Rise time          | $t_r$          | $V_{OUT} = 12 \text{ V}$ , $R_L = 820 \Omega$ | —      | 0.04 | 0.2  | $\mu\text{s}$ |
| Output Fall time          | $t_f$          | $V_{OUT} = 12 \text{ V}$ , $R_L = 820 \Omega$ | —      | 0.18 | 0.3  | $\mu\text{s}$ |

## MAGNETIC CHARACTERISTICS over operating temperature and supply voltage range.

| Characteristic | Symbol    | Test Conditions           | Limits |      |      | Units |
|----------------|-----------|---------------------------|--------|------|------|-------|
|                |           |                           | Min.   | Typ. | Max. |       |
| Operate Point  | $B_{OP}$  | Output switches on to off | 0      | 15   | 27.5 | G     |
| Release Point  | $B_{RP}$  | Output switches off to on | -12.5  | 0    | 7.5  | G     |
| Hysteresis     | $B_{hys}$ | $B_{OP} - B_{RP}$         | 5.0    | 15   | 35   | G     |

- NOTES: 1. Magnetic switch points are specified as the difference in magnetic fields at the two Hall elements.  
 2. As used here, negative flux densities are defined as less than zero (algebraic convention).  
 3. Typical values are at  $T_A = 25^\circ\text{C}$  and  $V_{CC} = 12 \text{ V}$ .  
 4. 1 gauss (G) is exactly equal to 0.1 millitesla (mT).

# 3064 HALL-EFFECT GEAR-TOOTH SENSOR —AC COUPLED

## TYPICAL OPERATING CHARACTERISTICS

### SWITCH POINTS

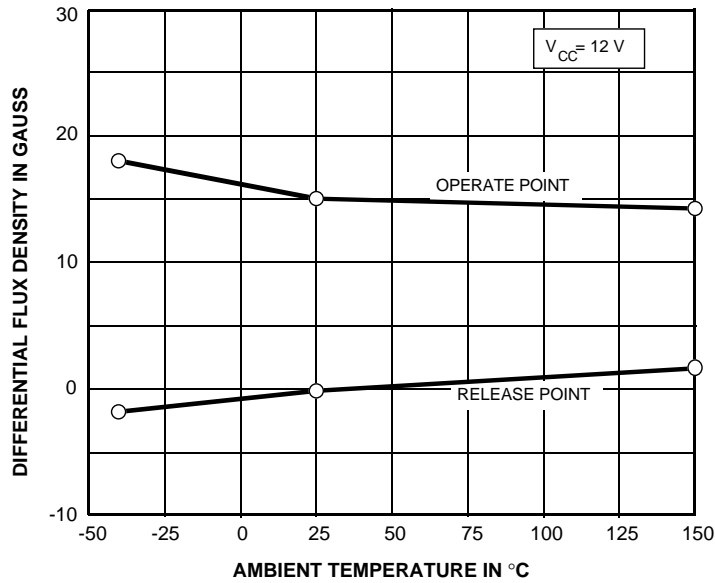

Dwg. GH-056-1

### OUTPUT SATURATION VOLTAGE

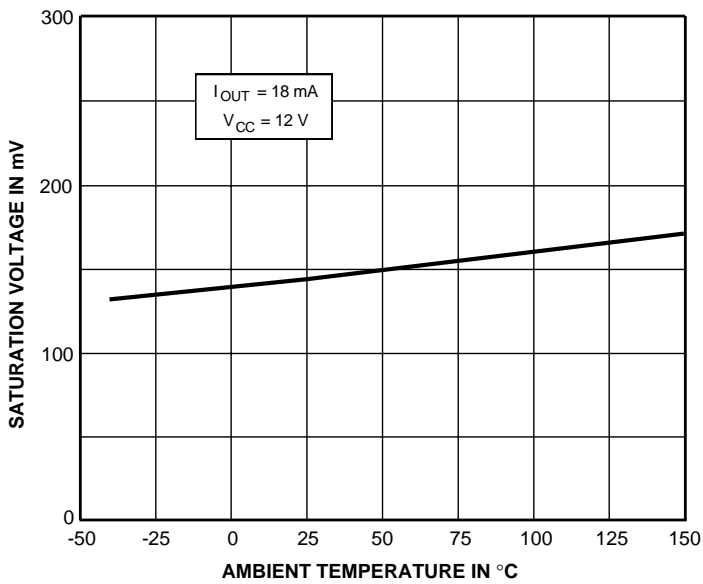

Dwg. GH-029-6

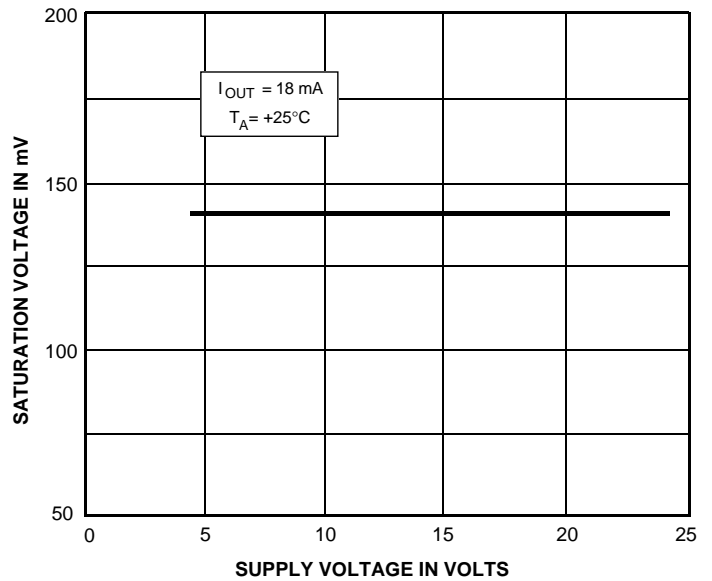

Dwg. GH-055-2

# 3064 HALL-EFFECT GEAR-TOOTH SENSOR —AC COUPLED

## TYPICAL OPERATING CHARACTERISTICS

### SUPPLY CURRENT

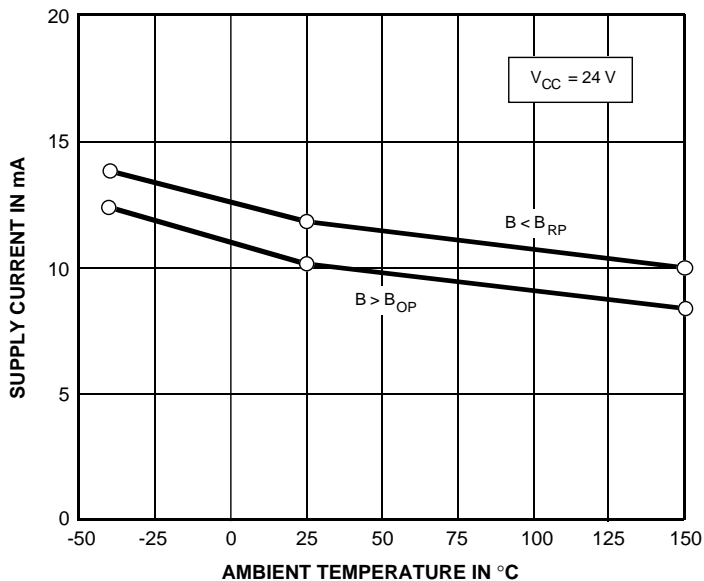

Dwg. GH-028-9

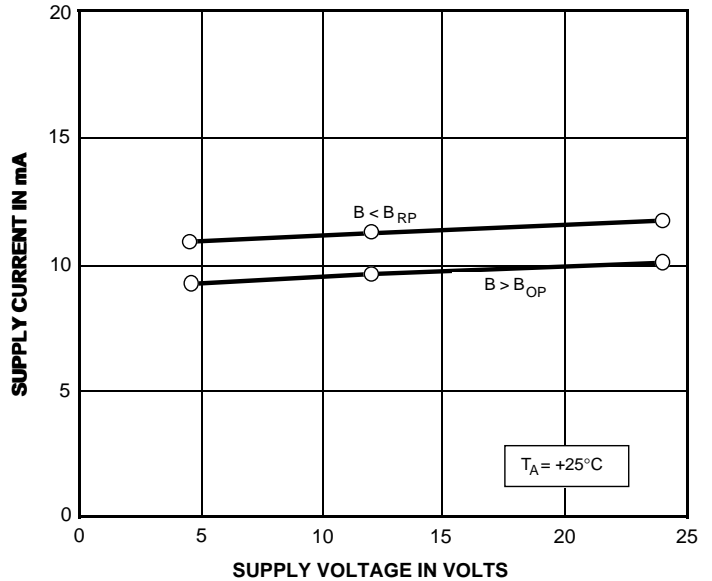

Dwg. GH-031-3

## APPLICATIONS INFORMATION

The A3064LKA is a versatile high-precision differential sensing device that can be used in a wide range of applications. Careful choice of the sensor IC, target material and shape, magnet material and shape, and assembly techniques enables large working air gaps and high switch-point accuracy over the system operating temperature range.

**Magnet Biasing.** To sense moving non-magnetized ferrous targets, these devices must be back biased by mounting the unbranded side on a small permanent magnet. Either magnetic pole (north or south) can be used.

The devices can be used without a back-biasing magnet. For example, the sensor can be used to detect a rotating ring magnet such as those found in brushless dc motors or in speed sensing applications.

**Sensor Operation.** These sensor ICs each contain two integrated Hall transducers (E1 and E2) that are used to sense a magnetic field differential across the face of the IC (see Sensor Location drawing). Referring to the Typical Transfer Characteristic (Figure 1), the trigger switches the output off (output high) when  $B_{E1} - B_{E2} > B_{OP}$  and switches the output on (output low) when  $B_{E1} - B_{E2} < -B_{OP}$ .

**Figure 1  
TYPICAL TRANSFER CHARACTERISTIC**

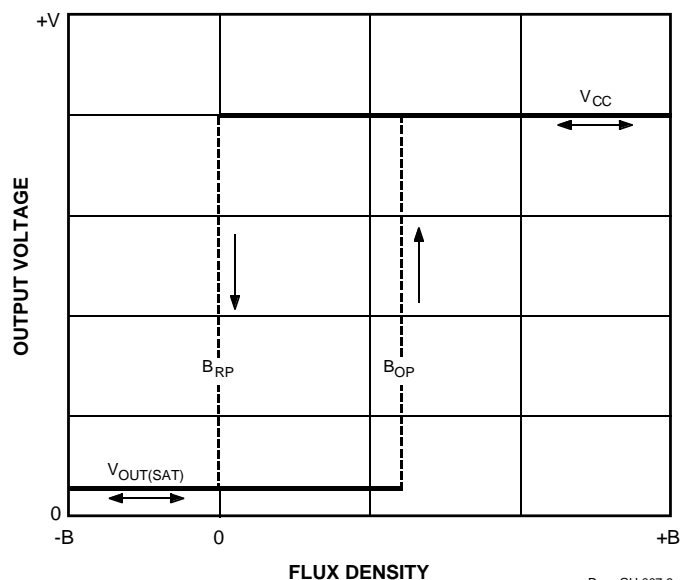

Dwg. GH-007-6

### APPLICATIONS INFORMATION (cont'd)

low) when  $B_{E1} - B_{E2} < B_{RP}$ . The difference between  $B_{OP}$  and  $B_{RP}$  is the hysteresis of the device.

Note that powering up in the absence of a differential magnetic field (less than the device  $B_{OP}$  and higher than the device  $B_{RP}$ ) will allow an indeterminate output state. The correct output state is warranted after the first excursion beyond  $B_{OP}$  or  $B_{RP}$ .

Figure 2 relates the output state of a back-biased sensor IC, with switching characteristics shown in Figure 1, to the target gear profile and position. Assume a north pole back-bias configuration (equivalent to a south pole at the face of the device). The motion of the gear produces a phase-shifted field at E1 and E2 (Figure 2(a)); internal conditioning circuitry subtracts the fields at the two elements (Figure 2(b)); this differential field is band-pass filtered to remove dc offset components and then fed into a Schmitt trigger; the Schmitt trigger switches the output transistor at the thresholds  $B_{OP}$  and  $B_{RP}$ . As shown (Figure 2(c)), the IC output is low whenever sensor E2 faces a (ferrous) gear tooth and sensor E1 faces air. The output is high when sensor E1 faces air and sensor E2 faces a ferrous target.

**AC-Coupled Operation.** Steady-state magnet and system offsets are eliminated using an on-chip differential band-pass filter. The lower frequency cut-off of this patented filter is set using an external capacitor, the value of which can range from 0.01  $\mu\text{F}$  to 10  $\mu\text{F}$ . The high-frequency cut-off of this filter is set at 30 kHz by an internal integrated capacitor.

The differential structure of this filter improves the ability of the IC to reject single-ended noise on the ground or supply line and, as a result, makes it more resistant to radio-frequency and electromagnetic interference typically seen in hostile remote-sensing environments. This filter configuration also increases system tolerance to capacitor degradation at high temperatures, allowing the use of an inexpensive external ceramic capacitor.

**Low-Frequency Operation.** Low-frequency operation of the sensor is set by the value of an external capacitor. Ideally, the differential flux density range (determined by the applied target) vs. air gap assumes a perfect sinusoidal input. Figure 3 provides the low-frequency cut-off (-3 dB point) of the filter as a function of capacitance value. This information should be used with care. In reality, when used with gear teeth,

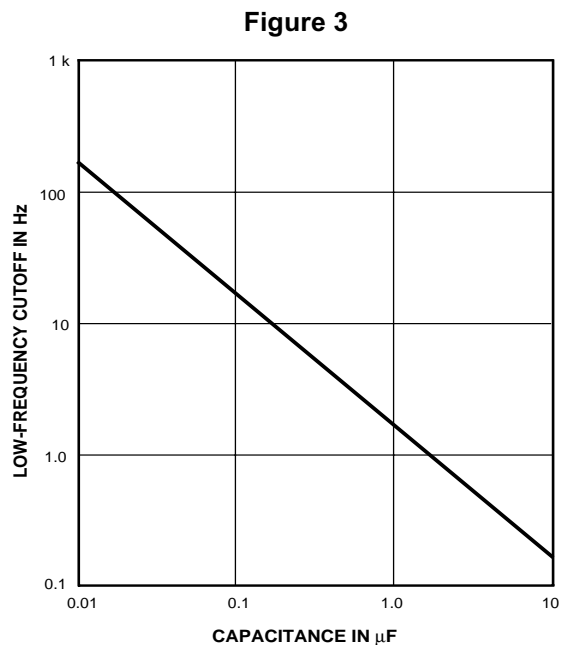
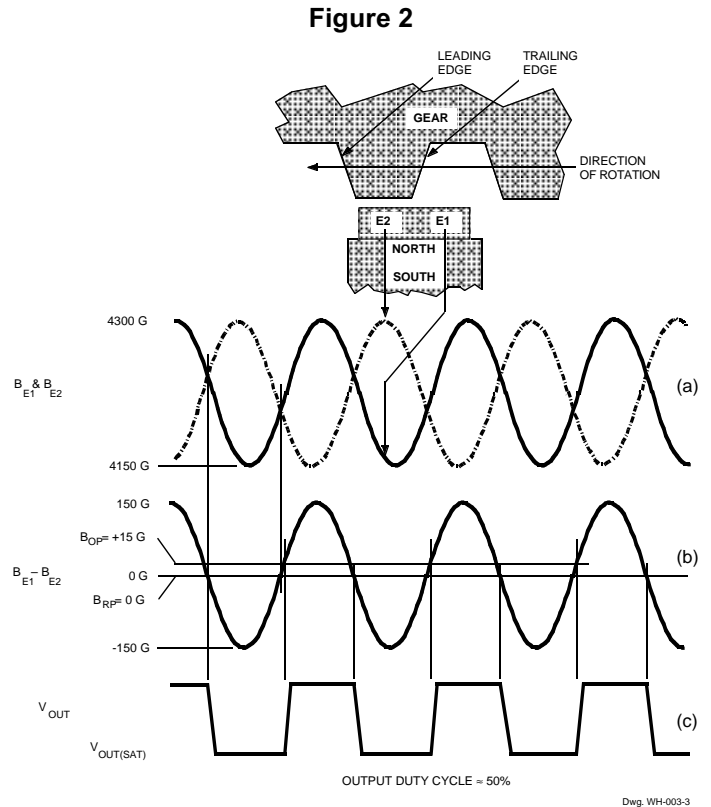

# 3064 HALL-EFFECT GEAR-TOOTH SENSOR —AC COUPLED

## APPLICATIONS INFORMATION (cont'd)

the teeth create transitions in the magnetic field that have a much higher frequency content than the basic rotational speed of the target. This allows the device to sense speeds much lower than those indicated by the graph for a given capacitor value.

**Capacitor Characteristics.** The major requirement for the external capacitor is its ability to operate in a bipolar (non-polarized) mode. Another important requirement is the low leakage current of the capacitor (equivalent parallel resistance should be greater than 500 k $\Omega$ ). To maintain proper operation with frequency, capacitor values should be held to within  $\pm 30\%$  over the operating temperature range. The commonly available Z5U ceramic capacitor temperature code should not be used in this application.

**Magnet Selection.** The A3064LKA can be used with a wide variety of commercially available permanent magnets. The selection of the magnet depends on the operational and environmental requirements of the sensing system. For systems that require high accuracy and large working air gaps or an extended temperature range, the usual magnet material of choice is rare-earth samarium cobalt (SmCo). This magnet material has a high energy product and can operate over an extended temperature range. For systems that require low-cost solutions for an extended temperature range, AlNiCo 8 can be used. Due to its relatively low energy product, smaller operational air gaps can be expected. Neodymium iron boron (NeFeB) can be used over moderate temperature ranges when large working air gaps are required. Of these three magnet materials, AlNiCo 8 is the least expensive by volume and SmCo is the most expensive.

Extensive applications information for Hall-effect sensors is available in:

- Hall-Effect IC Applications Guide, Application Note 27701;
- Hall-Effect Devices: Soldering, Gluing, Potting, Encapsulating, and Lead Forming, Application Note 27703.1;
- Soldering of Through-Hole Hall-Sensor Devices, Application Note 27703; and
- Soldering of Surface-Mount Hall-Sensor Devices, Application Note 27703.2.

All are provided in Allegro Electronic Data Book, AMS-702. or at

[www.allegromicro.com](http://www.allegromicro.com)

**Figure 4**  
**SENSOR LOCATIONS**  
( $\pm 0.005$  [0.13 mm] die placement)

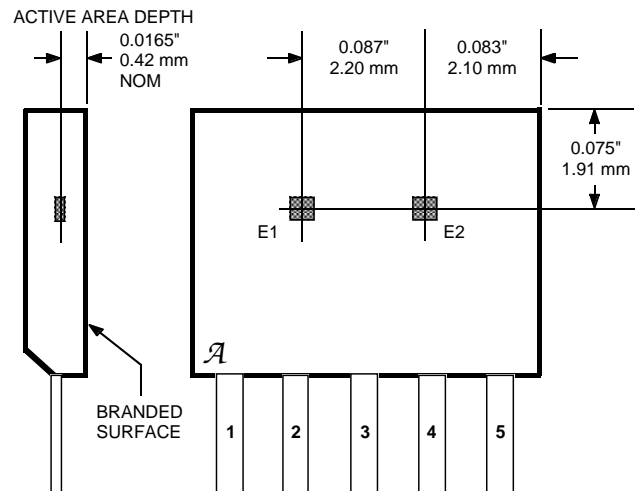

Dwg. MH-007E

**3064**  
**HALL-EFFECT**  
**GEAR-TOOTH SENSOR**  
**—AC COUPLED**

**CRITERIA FOR DEVICE QUALIFICATION**

All Allegro sensors are subjected to stringent qualification requirements prior to being released to production. To become qualified, except for the destructive ESD tests, no failures are permitted.

| Qualification Test                     | Test Method and Test Conditions                                   | Test Length      | Samples    | Comments  |
|--|---|------------------|------------|---|
| Biased Humidity (HAST)                 | JESD22-A101,<br>RH = 85%  | 2000 hrs         | 320        | $V_{CC} = V_{OUT} = 12\text{ V}$<br>116 pcs at $T_A = 25^\circ\text{C}$<br>116 pcs at $T_A = 150^\circ\text{C}$ |
| High-Temperature Operating Life (HTOL) | JESD22-A108,<br>$T_J \leq 190^\circ\text{C}$                      | 2000 hrs         | 146        | $V_{CC} = V_{OUT} = 12\text{ V}$<br>116 pcs at $T_A = 25^\circ\text{C}$<br>30 pcs at $T_A = 150^\circ\text{C}$  |
| Accelerated HTOL                       | $T_A = 175^\circ\text{C}$ , $T_J \leq 190^\circ\text{C}$          | 500 hrs          | 50         | $V_{CC} = V_{OUT} = 7.5\text{ V}$   |
| Autoclave, Unbiased                    | JESD22-A102, Condition C,<br>$T_A = 121^\circ\text{C}$ at 15 psig | 192 hrs          | 77         |   |
| Solder Heat                            |   |                  | 22         |   |
| High-Temperature (Bake) Storage Life   | MIL-STD-883, Method 1008,<br>$T_A = 170^\circ\text{C}$            | 2000 hrs         | 77         |   |
| Temperature Cycle (unbiased)           | MIL-STD-883, Method 1010,<br>+25°C to +150°C                      | 2000 cycles      | 153        |   |
| ESD, Human Body Model                  | MIL-STD-883, Method 3015  | Pre/Post Reading | 3 per test | Test to failure,<br>All leads > 2 kV  |

*The products described herein are manufactured under one or more of the following U.S. patents: 5,045,920; 5,264,783; 5,442,283; 5,389,889; 5,581,179; 5,517,112; 5,619,137; 5,621,319; 5,650,719; 5,686,894; 5,694,038; 5,729,130; 5,917,320; and other patents pending.*

*Allegro MicroSystems, Inc. reserves the right to make, from time to time, such departures from the detail specifications as may be required to permit improvements in the performance, reliability, or manufacturability of its products. Before placing an order, the user is cautioned to verify that the information being relied upon is current.*

*Allegro products are not authorized for use as critical components in life-support appliances, devices, or systems without express written approval.*

*The information included herein is believed to be accurate and reliable. However, Allegro MicroSystems, Inc. assumes no responsibility for its use; nor for any infringements of patents or other rights of third parties that may result from its use.*

# 3064 HALL-EFFECT GEAR-TOOTH SENSOR —AC COUPLED

**Dimensions in Inches**  
(controlling dimensions)

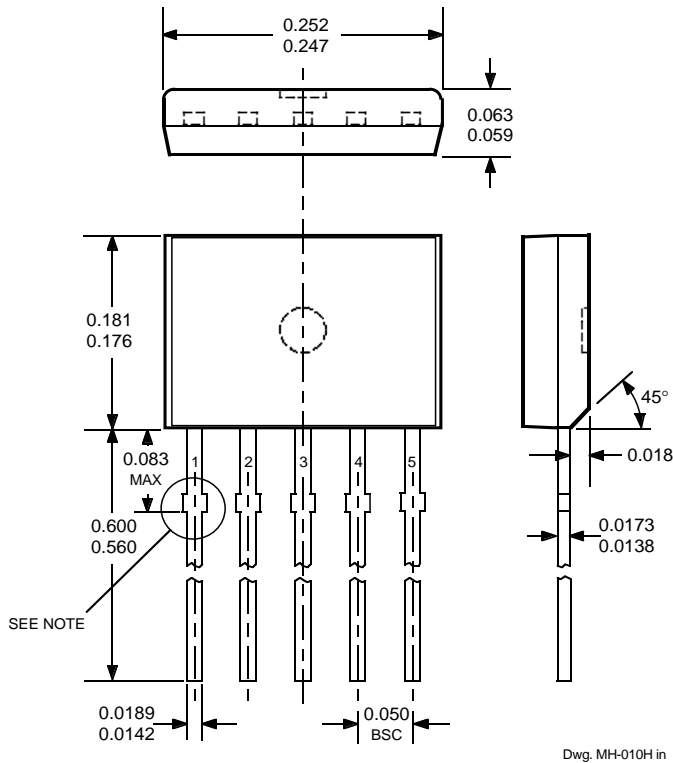

**Dimensions in Millimeters**  
(for reference only)

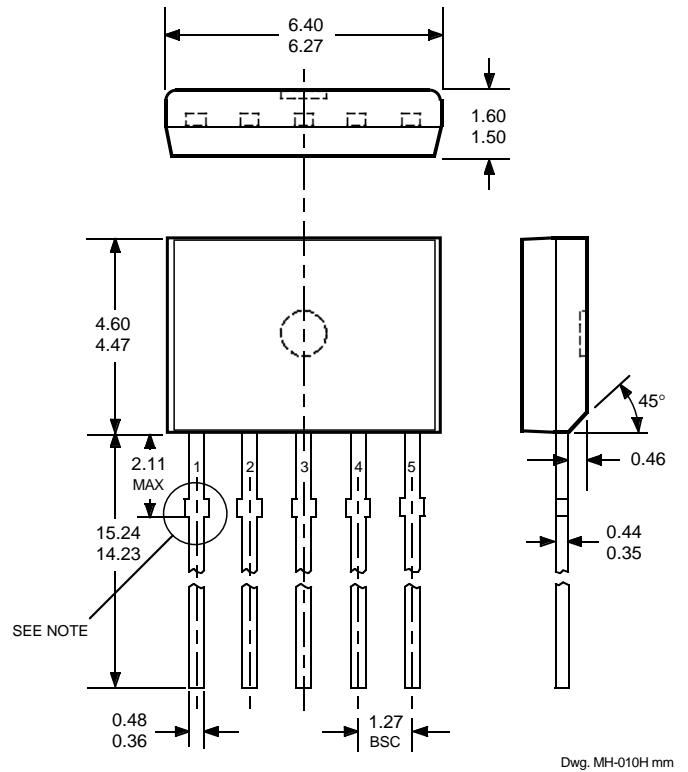

## Surface-Mount Lead Form (order A3064LKA-TL)

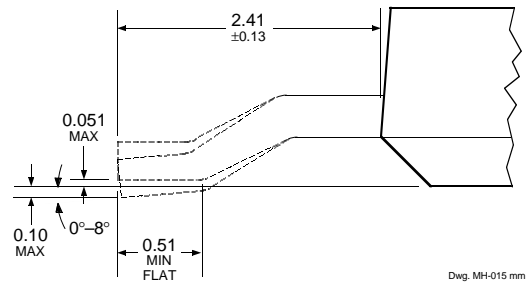
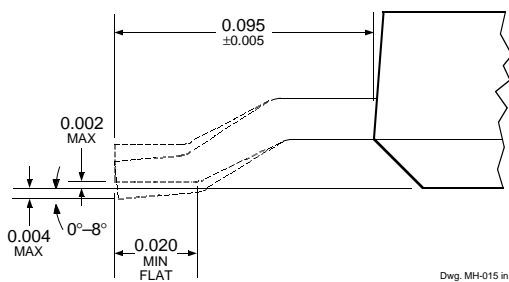

- NOTES:
1. Tolerances on package height and width represent allowable mold offsets. Dimensions given are measured at the widest point (parting line).
  2. Exact body and lead configuration at vendor's option within limits shown.
  3. Height does not include mold gate flash.
  4. Recommended minimum PWB hole diameter to clear transition area is 0.035 (0.89 mm).
  5. Where no tolerance is specified, dimension is nominal.
  6. Supplied in bulk pack (500 pieces per bag).



LittleDiode supplies new, hard to find or obsolete electronic components and semiconductors all over the world.

With over two million different components listed you are sure to find the part you need.

Feel free to visit us today at our online store:

[LittleDiode.com](http://LittleDiode.com)

Looking forward to providing you with the best possible service.